

Coaxial

Precision Fixed Attenuator BW-N30W50+

50Ω 30 dB DC to 18 GHz



CASE STYLE: GH1788

The Big Deal

- High Power Handling, 50W
- Excellent VSWR, 1.30 typ.
- Wide Frequency Range, DC to 18 GHz

Product Overview

The BW-N30W50+ 30 dB precision fixed attenuator achieves outstanding flatness versus frequency from DC to 18 GHz while handling high power signals up to 50W. High power handling, excellent VSWR, and precise performance make the BW-N30W50+ ideal for a variety of test lab and system applications including high power measurement, high power termination, improving matching, test setups, and other functions demanding accurate attenuation and high power capability.

Key Features

Feature	Advantages
Wide Frequency Range	DC to 18 GHz frequency range gives the BW-N30W50+ attenuator versatile application functionality.
Excellent VSWR, 1.30 typ.	Well-matched for 50Ω systems; reduces effects of phase variation.
Flat attenuation	Accurate performance within ±0.5 dB over the full frequency range.
Rugged Construction	Excellent durability for a long lifetime of use.
Heat Dissipation Fins	Designed to dissipate heat efficiently, the BW-N30W50+ requires no external cooling equipment.
Compact Size (2.65" x 2.65" x 4.5")	Outstanding performance capability and power handling without prohibitive space constraints.

Notes

- A. Performance and quality attributes and conditions not expressly stated in this specification document are intended to be excluded and do not form a part of this specification document.
B. Electrical specifications and performance data contained in this specification document are based on Mini-Circuit's applicable established test performance criteria and measurement instructions.
C. The parts covered by this specification document are subject to Mini-Circuits standard limited warranty and terms and conditions (collectively, "Standard Terms"); Purchasers of this part are entitled to the rights and benefits contained therein. For a full statement of the Standard Terms and the exclusive rights and remedies thereunder, please visit Mini-Circuits' website at www.minicircuits.com/MCLStore/terms.jsp



Coaxial Precision Fixed Attenuator

BW-N30W50+

50Ω 50W 30dB DC to 18 GHz

Maximum Ratings

Operating Temperature -55°C to 100°C**

Storage Temperature -55°C to 100°C

**85°C with output into open or short.

Permanent damage may occur if any of these limits are exceeded.

Coaxial Connections

IN (50W) N-Male

OUT N-Female

Outline Drawing

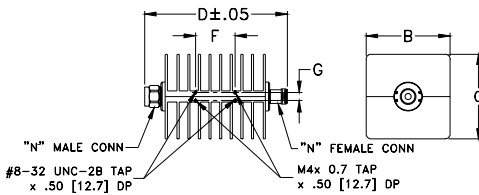

Outline Dimensions (inch/mm)

B	C	D	E	F	G	wt.
2.65	2.65	4.50	--	1.25	.25	grams
67.31	67.31	114.30	--	31.75	6.35	720.0

Simplified Electrical Schematic

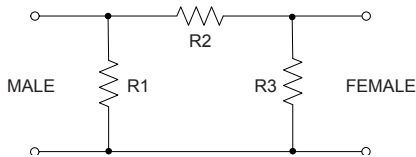

Features

- DC to 18 GHz
- precise attenuation
- excellent VSWR, 1.30 typ
- passivated stainless steel N-type connectors
- unidirectional

Applications

- matching
- instrumentation
- test set-ups
- high power measurements



Generic photo used for illustration purposes only

CASE STYLE: GH1788

Connectors	Model
N-type	BW-N10W50+

+RoHS Compliant

The +Suffix identifies RoHS Compliance. See our web site for RoHS Compliance methodologies and qualifications

Electrical Specifications at 25°C

Parameter	Condition (GHz)	Min.	Typ.	Max.	Unit
Frequency Range		DC	—	18	GHz
Attenuation	DC - 18	28.50	30.00	31.50	dB
VSWR	IN	—	—	1.45	:1
	OUT	—	—	1.5	
Input Power ¹	DC - 18	—	—	50	W

1. Max. power at 25°C ambient, derate linearly to 20W at 100°C. Peak power 500W max. 5µsec. pulse width, 100Hz PRF, input N-Male. 5W max. at N-Female.

Typical Performance Data

Frequency (GHz)	Attenuation (dB)	VSWR (:1)	
		IN	OUT
0.01	30.17	1.00	1.01
2.0	30.36	1.07	1.02
4.0	30.37	1.16	1.07
6.0	30.27	1.13	1.08
8.0	30.12	1.16	1.09
10.0	30.03	1.23	1.15
12.4	29.78	1.17	1.02
14.0	29.61	1.29	1.09
16.0	29.35	1.12	1.10
18.0	29.26	1.02	1.12

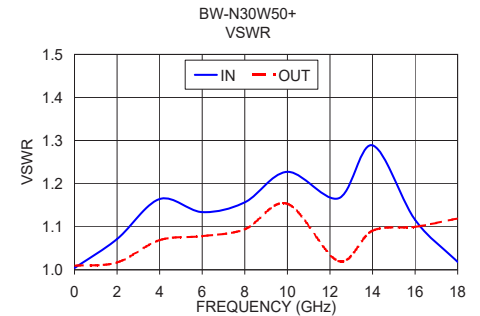
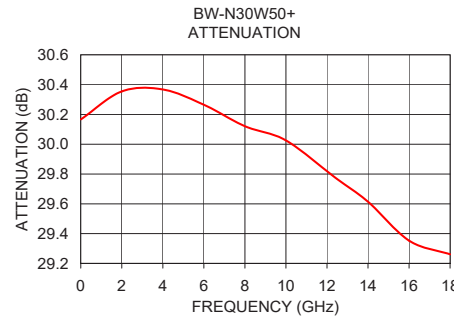

Notes

- Performance and quality attributes and conditions not expressly stated in this specification document are intended to be excluded and do not form a part of this specification document.
- Electrical specifications and performance data contained in this specification document are based on Mini-Circuit's applicable established test performance criteria and measurement instructions.
- The parts covered by this specification document are subject to Mini-Circuit's standard limited warranty and terms and conditions (collectively, "Standard Terms"); Purchasers of this part are entitled to the rights and benefits contained therein. For a full statement of the Standard Terms and the exclusive rights and remedies thereunder, please visit Mini-Circuit's website at www.minicircuits.com/MCLStore/terms.jsp



www.minicircuits.com P.O. Box 350166, Brooklyn, NY 11235-0003 (718) 934-4500 sales@minicircuits.com

REV. B
ECO-015873
BW-N30W50+
RS/CP/AM
221128
Page 1 of 1

Typical Performance Data

FREQUENCY (GHz)	ATTENUATION (dB)	VSWR (:1)
0.01	30.17	1.00
0.05	30.16	1.00
0.1	30.22	1.01
0.2	30.24	1.01
0.3	30.26	1.01
0.4	30.28	1.01
0.5	30.29	1.02
0.6	30.30	1.02
0.7	30.29	1.02
0.8	30.30	1.03
0.9	30.31	1.03
1.0	30.31	1.04
1.4	30.34	1.05
1.8	30.35	1.07
2.0	30.36	1.07
2.4	30.36	1.08
2.8	30.36	1.10
3.0	30.37	1.11
3.4	30.37	1.14
3.8	30.37	1.16
4.0	30.37	1.16
4.4	30.36	1.16
4.8	30.34	1.15
5.0	30.34	1.15
5.4	30.31	1.14
5.8	30.28	1.14
6.0	30.27	1.13
6.4	30.25	1.12
6.8	30.22	1.10
7.0	30.21	1.09
7.4	30.18	1.10
7.8	30.15	1.14
8.0	30.12	1.16
8.4	30.09	1.19
8.8	30.08	1.23
9.0	30.08	1.24
9.4	30.07	1.25
9.8	30.03	1.23
10.0	30.03	1.23
10.4	29.97	1.21
10.8	29.92	1.20
11.0	29.89	1.18
11.4	29.86	1.15
11.8	29.82	1.13
12.0	29.81	1.13
12.4	29.78	1.17
12.8	29.72	1.21
13.0	29.71	1.22
13.4	29.66	1.25
13.8	29.61	1.28
14.0	29.61	1.29
14.4	29.52	1.29
14.8	29.43	1.26
15.0	29.40	1.23
15.4	29.38	1.18
15.8	29.36	1.14
16.0	29.35	1.12
16.4	29.36	1.08
16.8	29.34	1.06
17.0	29.34	1.06
17.4	29.31	1.05
17.8	29.29	1.03
18.0	29.26	1.02

Typical Performance Curves

Attenuation

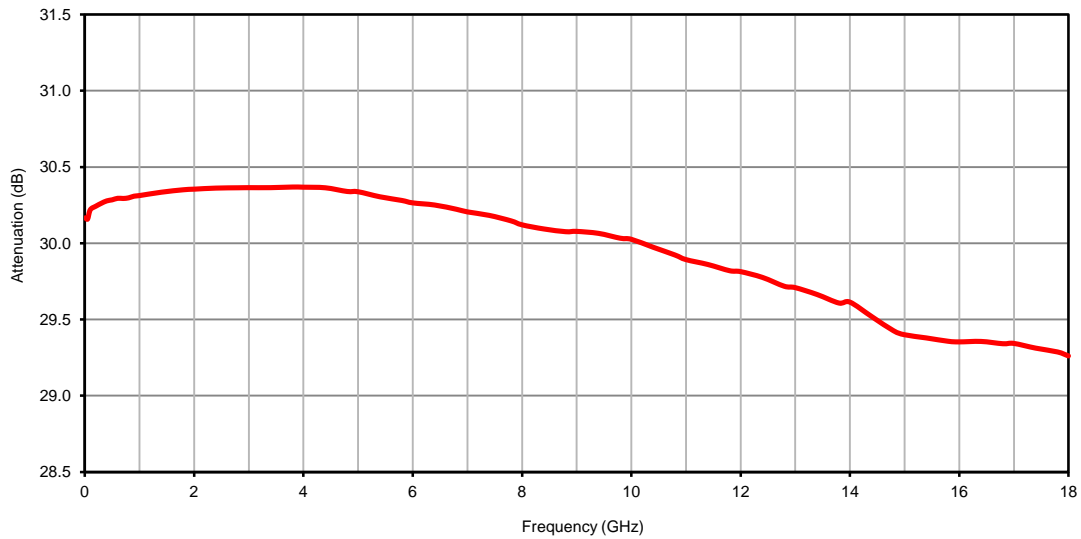

VSWR

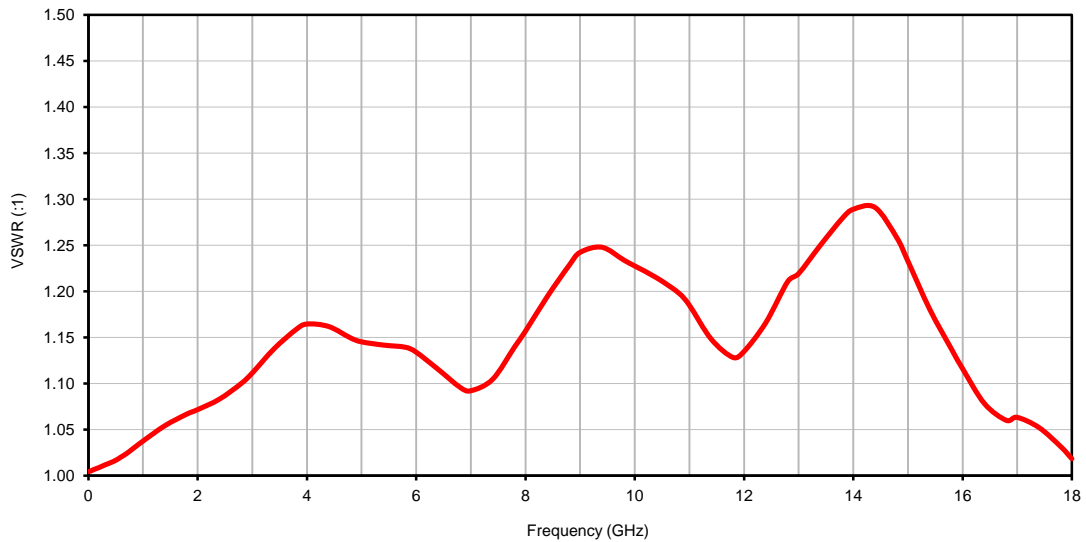

Case Style

GH

Outline Dimensions

GH1788

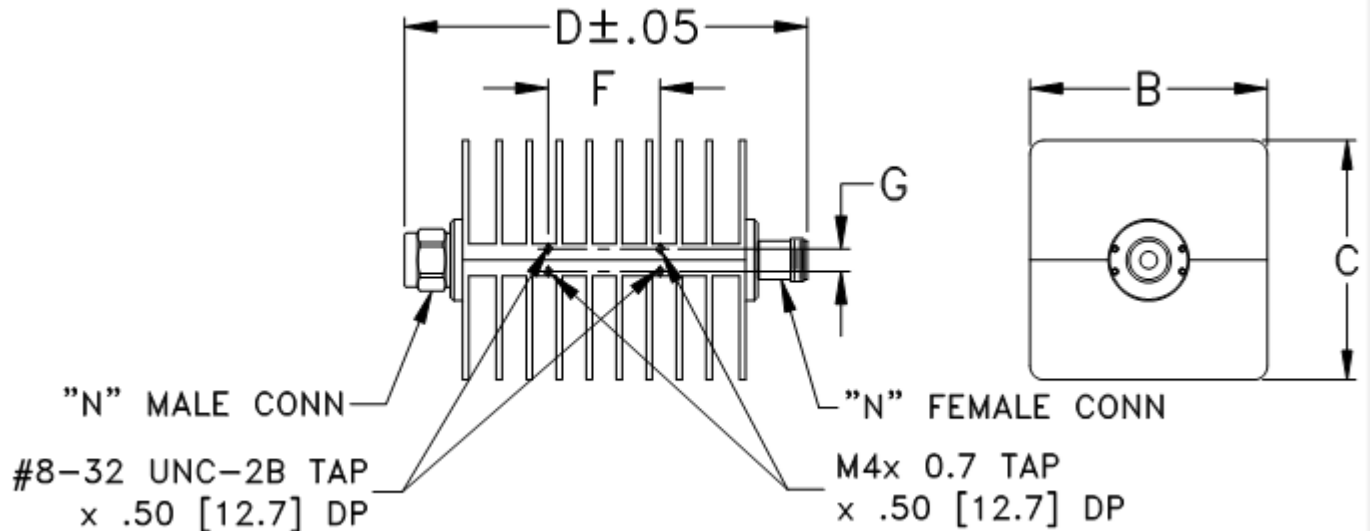

CASE #.	A	B	C	D	E	F	G	H	J	WT. GRAM
GH1788	--	2.65 (67.31)	2.65 (67.31)	4.50 (114.30)	--	1.25 (31.76)	.25 (6.35)	--	--	720

Dimensions are in inches (mm). Tolerances: 2Pl. $\pm .03$; 3Pl. $\pm .015$

Notes:

1. Case Material: Aluminum alloy.
2. Case finish: Black anodize.

 **Mini-Circuits**[®]

INTERNET <http://www.minicircuits.com>

P.O. Box 350166, Brooklyn, New York 11235-0003 (718) 934-4500 Fax (718) 332-4661

Distribution Centers NORTH AMERICA 800-654-7949 • 417-335-5935 • Fax 417-335-5945 • EUROPE 44-1252-832600 • Fax 44-1252-837010

Mini-Circuits ISO 9001 & ISO 14001 Certified



All Mini-Circuits products are manufactured under exacting quality assurance and control standards, and are capable of meeting published specifications after being subjected to any or all of the following physical and environmental test.

Specification	Test/Inspection Condition	Reference/Spec
Operating Temperature	-55° to 100°C Ambient Environment	Individual Model Data Sheet
Storage Temperature	-55° to 100° C Ambient Environment	Individual Model Data Sheet
Barometric Pressure	100,000 Feet	MIL-STD-202, Method 105, Condition D
Humidity	90% RH, 65°C Units may require bake-out after humidity to restore full performance.	MIL-STD-202, Method 103
Thermal Shock	-65° to 125°C, 5 cycles	MIL-STD-202, Method 107, Condition B
Vibration (High Frequency)	20g peak, 10-2000 Hz, 12 times in each of three perpendicular directions (total 36)	MIL-STD-202, Method 204, Condition D
Mechanical Shock	100g, 6ms sawtooth, 3 shocks each direction 3 axes (total 18)	MIL-STD-202, Method 213, Condition I