

# Surface Mount Bandpass Filter

## BPF-C70+

50Ω 69.5 to 70.5 MHz



Generic photo used for illustration purposes only  
CASE STYLE: HU1186

### The Big Deal

- Narrow bandwidth of 1.43% fractional BW
- High rejection of 50 dB min. from 80-1000 MHz
- Good VSWR 1.3:1 typical in passband
- Miniature shielded package

### Product Overview

The BPF-C70+ is a narrow band bandpass filter in a shield package (size of 0.87" x 0.80" x 0.25") fabricated using SMT technology. It has more than 50 dB rejection up to 1000 MHz. This unit uses a miniature high Q capacitors and wire welded inductors for high reliability.

### Key Features

Feature	Advantages
Narrow bandwidth of (1.43 % fractional BW)	Narrow bandwidth helps in adjacent channel rejection and increased selectivity.
High rejection, 50dB Min. from 80-1000MHz	Achieving 50 dB rejection over 80-1000 MHz, this design provides good performance in rejecting harmonics and sub harmonics.
Shielded case	Reduced interference with the surrounding components.

#### Notes

- A. Performance and quality attributes and conditions not expressly stated in this specification document are intended to be excluded and do not form a part of this specification document.  
B. Electrical specifications and performance data contained in this specification document are based on Mini-Circuit's applicable established test performance criteria and measurement instructions.  
C. The parts covered by this specification document are subject to Mini-Circuits standard limited warranty and terms and conditions (collectively, "Standard Terms"); Purchasers of this part are entitled to the rights and benefits contained therein. For a full statement of the Standard Terms and the exclusive rights and remedies thereunder, please visit Mini-Circuits' website at [www.minicircuits.com/MCLStore/terms.jsp](http://www.minicircuits.com/MCLStore/terms.jsp)



# Surface Mount Bandpass Filter

50Ω 69.5 to 70.5 MHz

## BPF-C70+



Generic photo used for illustration purposes only  
CASE STYLE: HU1186

### Features

- Good VSWR, 1.3:1 typical in passband
- Sharp insertion roll-off
- Aqueous washable
- Miniature shield package

### Applications

- Military hi-rel systems
- High rejection application
- Image rejection
- IF signal processing

### Electrical Specifications at 25°C

Parameter	F#	Frequency (MHz)	Min.	Typ.	Max.	Unit
Pass Band	Center Frequency	—	—	70	—	MHz
	Insertion Loss	F1-F2	69.5-70.5	6.4	8	dB
	VSWR	F1-F2	69.5-70.5	1.3	1.7	:1
Stop Band, Lower	Insertion Loss	DC-F3	DC-66	20	28	dB
	VSWR	DC-F3	DC-66	—	9	:1
Stop Band, Upper	Insertion Loss	F4-F5	75-1000	20	31	dB
	VSWR	F4-F5	75-1000	—	8	:1

### Maximum Ratings

Operating Temperature	-40°C to 85°C
Storage Temperature	-55°C to 100°C
RF Power Input	80 mW max.

Permanent damage may occur if any of these limits are exceeded.

### Functional Schematic

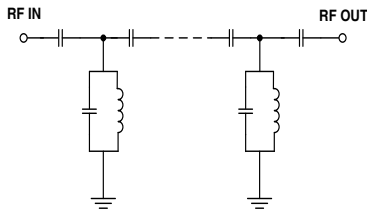

### Typical Frequency Response

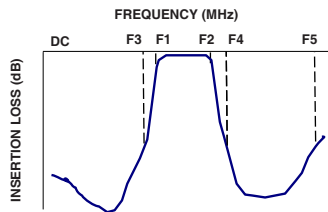

### Typical Performance Data at 25°C

Frequency (MHz)	Insertion Loss (dB)	VSWR (:1)	Frequency (MHz)	Group Delay (nsec)
1.0	95.83	2471.84	69.50	243.53
10.0	91.61	1844.81	69.60	241.18
50.0	84.69	500.90	69.70	238.75
60.0	65.44	114.85	69.80	236.98
66.0	32.23	15.29	69.90	234.99
67.5	14.99	3.91	70.00	233.43
69.5	6.28	1.25	70.10	232.43
70.0	6.07	1.17	70.20	231.60
70.5	6.05	1.12	70.30	230.98
73.0	13.22	2.33	70.40	230.68
75.0	31.62	9.45	70.50	229.83
80.0	59.41	42.67	70.60	230.17
100.0	80.41	229.35	70.70	230.71
260.0	76.89	195.95	70.80	231.03
400.0	69.51	125.98	70.90	231.67
500.0	65.13	148.72	71.00	233.54
750.0	60.37	106.87	71.50	241.81
800.0	59.92	103.36	72.00	257.29
900.0	58.25	96.53	72.50	260.49
1000.0	54.88	88.22	73.00	233.19

### +RoHS Compliant

The +Suffix identifies RoHS Compliance. See our web site for RoHS Compliance methodologies and qualifications

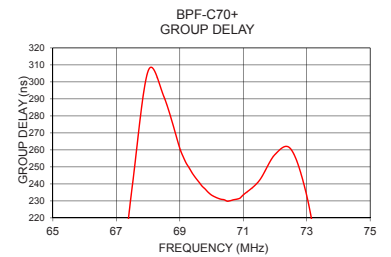
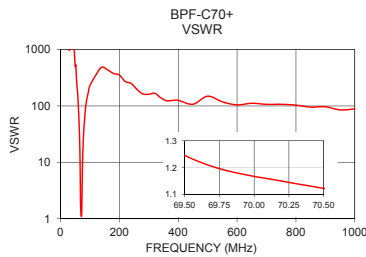
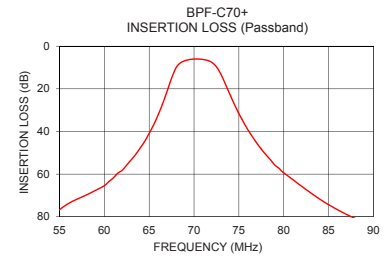
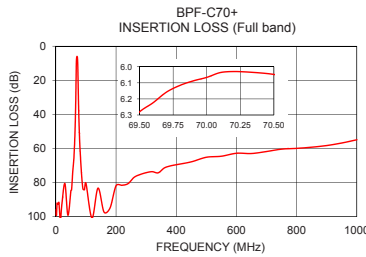

### Notes

- Performance and quality attributes and conditions not expressly stated in this specification document are intended to be excluded and do not form a part of this specification document.
- Electrical specifications and performance data contained in this specification document are based on Mini-Circuit's applicable established test performance criteria and measurement instructions.
- The parts covered by this specification document are subject to Mini-Circuits standard limited warranty and terms and conditions (collectively, "Standard Terms"); Purchasers of this part are entitled to the rights and benefits contained therein. For a full statement of the Standard Terms and the exclusive rights and remedies thereunder, please visit Mini-Circuits' website at [www.minicircuits.com/MCLStore/terms.jsp](http://www.minicircuits.com/MCLStore/terms.jsp)



## Pad Connections

INPUT	2
OUTPUT	9
NOT CONNECTED	6 & 13
GROUND	1,3,4,5,7,8,10,11,12,14

**Demo Board MCL P/N: TB-500+**  
**Suggested PCB Layout (PL-294)**

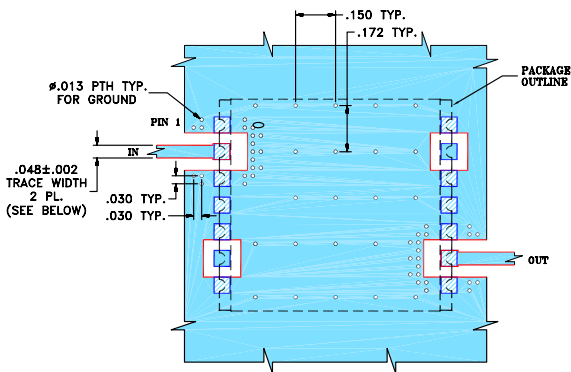

**NOTES:**

- TRACE WIDTH IS SHOWN FOR ROGERS R04850B.  
 DIELECTRIC THICKNESS:  $.030 \pm .002$ ;  
 COPPER: 1/2 OZ ON EACH SIDE.  
 FOR OTHER MATERIALS TRACE WIDTH MAY NEED TO BE MODIFIED.
- BOTTOM SIDE OF THE PCB IS CONTINUOUS GROUND PLANE.

- DENOTES PCB COPPER LAYOUT WITH SMOBC (SOLDER MASK OVER BARE COPPER)
- DENOTES COPPER LAND PATTERN FREE OF SOLDERMASK

## Outline Drawing

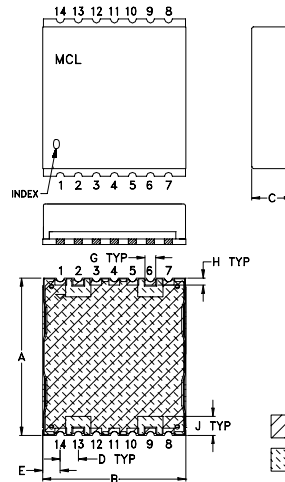

## Outline Dimensions ( inch / mm )

A	B	C	D	E	F	G	H
.870	.800	.25	.100	.097	--	.060	.040
22.10	20.32	6.35	2.54	2.46	--	1.52	1.02
J	K	L	M	N	P		wt
.105	.910	--	.060	.060	--		grams
2.67	23.11	--	1.52	1.52	--		2.85

*Note: Please refer to case style drawing for details*

## PCB Land Pattern

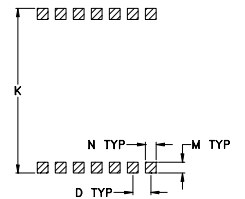

Suggested Layout,  
 Tolerance to be within  $\pm .002$

**Notes**

- Performance and quality attributes and conditions not expressly stated in this specification document are intended to be excluded and do not form a part of this specification document.
- Electrical specifications and performance data contained in this specification document are based on Mini-Circuit's applicable established test performance criteria and measurement instructions.
- The parts covered by this specification document are subject to Mini-Circuits standard limited warranty and terms and conditions (collectively, "Standard Terms"); Purchasers of this part are entitled to the rights and benefits contained therein. For a full statement of the Standard Terms and the exclusive rights and remedies thereunder, please visit Mini-Circuits' website at [www.minicircuits.com/MCLStore/terms.jsp](http://www.minicircuits.com/MCLStore/terms.jsp)



*Typical Performance Data*

FREQ. (MHz)	INSERTION LOSS			INPUT RETURN LOSS			OUTPUT RETURN LOSS		
	(dB)			(dB)			(dB)		
	@-40°C	@+25°C	@+85°C	@-40°C	@+25°C	@+85°C	@-40°C	@+25°C	@+85°C
1.0	96.78	103.91	95.60	0.00	0.01	0.01	0.00	0.00	0.00
5.0	101.55	100.27	112.36	0.00	0.01	0.00	0.00	0.01	0.00
10.0	99.18	97.05	97.91	0.00	0.00	0.00	0.01	0.00	0.01
20.0	98.76	87.53	90.04	0.00	0.00	0.00	0.00	0.01	0.01
30.0	87.46	98.75	105.41	0.00	0.00	0.00	0.00	0.00	0.00
30.5	95.16	93.36	89.27	0.00	0.00	0.00	0.01	0.00	0.01
40.0	89.25	85.17	104.68	0.01	0.01	0.01	0.00	0.01	0.02
50.0	93.07	99.58	99.43	0.02	0.03	0.04	0.01	0.03	0.05
52.0	99.72	93.68	88.62	0.03	0.03	0.04	0.02	0.04	0.06
53.0	91.95	88.39	97.84	0.03	0.04	0.05	0.02	0.04	0.06
54.0	102.02	92.07	89.64	0.04	0.05	0.06	0.03	0.05	0.07
55.0	89.61	88.73	92.08	0.04	0.06	0.07	0.05	0.06	0.09
56.0	91.07	84.15	88.95	0.06	0.07	0.08	0.05	0.08	0.10
57.0	83.48	81.59	86.61	0.07	0.08	0.10	0.06	0.08	0.12
58.0	81.33	81.70	80.96	0.08	0.10	0.12	0.07	0.10	0.14
59.0	76.59	77.15	77.46	0.10	0.12	0.15	0.10	0.13	0.17
60.0	72.46	72.68	72.16	0.13	0.15	0.19	0.13	0.17	0.22
65.0	42.05	41.41	40.10	0.60	0.70	0.86	0.75	0.88	1.08
66.0	32.93	32.18	30.79	0.99	1.16	1.46	1.32	1.54	1.91
67.0	21.96	21.21	19.89	2.04	2.43	3.15	2.94	3.46	4.39
68.0	10.69	10.52	10.27	6.70	7.86	9.90	10.87	12.99	16.60
68.5	7.50	7.73	8.05	12.82	14.19	16.56	27.43	39.19	31.91
69.0	6.13	6.53	7.05	21.39	22.51	25.41	26.63	25.97	25.85
69.5	5.56	6.00	6.61	31.06	30.78	33.35	27.21	27.32	28.51
69.6	5.50	5.94	6.55	30.59	30.27	32.26	27.64	27.85	29.38
69.7	5.44	5.90	6.51	29.64	29.47	31.12	28.12	28.49	30.40
69.8	5.39	5.85	6.48	28.71	28.71	30.25	28.69	29.20	31.58
69.9	5.36	5.83	6.47	28.00	28.14	29.63	29.42	30.10	32.94
70.0	5.33	5.79	6.46	27.58	27.75	29.22	30.42	31.21	34.46
70.1	5.31	5.79	6.45	27.30	27.55	29.01	31.70	32.62	36.04
70.2	5.30	5.78	6.45	27.22	27.54	28.99	33.54	34.47	37.31
70.3	5.29	5.79	6.46	27.28	27.65	29.11	36.03	36.79	37.71
70.4	5.29	5.79	6.48	27.43	27.90	29.35	39.71	39.34	36.96
70.5	5.30	5.80	6.51	27.65	28.23	29.70	45.04	40.83	35.58
71.0	5.43	5.98	6.79	29.47	30.95	29.95	33.23	31.98	28.27
71.5	5.78	6.41	7.36	28.58	27.68	25.17	26.50	24.18	20.82
72.0	6.48	7.26	8.48	24.76	25.74	28.30	18.23	16.69	14.47
72.5	7.94	9.01	10.68	28.06	25.54	20.01	11.64	10.69	9.29
73.0	10.94	12.35	14.47	12.61	11.28	9.57	6.69	6.24	5.58
73.5	15.65	17.15	19.34	6.37	6.00	5.43	3.81	3.71	3.52
74.0	20.99	22.33	24.34	3.75	3.68	3.50	2.42	2.46	2.45
74.5	26.07	27.24	29.00	2.50	2.52	2.48	1.72	1.79	1.84
75.0	30.66	31.68	33.20	1.81	1.85	1.85	1.30	1.38	1.45
80.0	56.96	57.23	57.55	0.35	0.38	0.41	0.31	0.35	0.39
90.0	71.33	72.24	71.38	0.11	0.12	0.14	0.09	0.12	0.15
100.0	77.69	76.10	77.93	0.05	0.07	0.09	0.05	0.07	0.10
150.0	86.65	79.83	87.51	0.04	0.05	0.07	0.02	0.05	0.06
200.0	89.64	88.85	84.39	0.06	0.08	0.10	0.02	0.06	0.09
250.0	83.04	87.55	84.79	0.08	0.10	0.12	0.05	0.08	0.10
260.0	86.64	86.46	88.06	0.09	0.11	0.14	0.05	0.09	0.10
300.0	83.89	77.18	79.06	0.11	0.13	0.16	0.06	0.10	0.13
400.0	73.79	73.84	72.98	0.16	0.18	0.22	0.09	0.15	0.17
500.0	68.42	68.80	68.67	0.18	0.21	0.25	0.11	0.18	0.21
600.0	67.26	67.52	67.50	0.18	0.22	0.25	0.13	0.20	0.24
700.0	65.66	64.91	65.04	0.17	0.22	0.26	0.13	0.20	0.24
750.0	64.33	64.69	64.46	0.18	0.22	0.26	0.14	0.21	0.25
800.0	64.67	63.97	63.47	0.17	0.22	0.25	0.12	0.21	0.25
900.0	61.96	61.96	62.01	0.17	0.23	0.26	0.12	0.20	0.26
1000.0	57.01	57.09	56.64	0.17	0.23	0.26	0.12	0.21	0.28

## Typical Performance Data

FREQ.  (MHz)	GROUP DELAY		
	(nsec)		
	@-40°C	@+25°C	@+85°C
69.0	266.85	260.06	251.17
69.1	261.72	255.52	247.70
69.2	256.81	251.53	244.30
69.3	252.23	247.40	241.53
69.4	248.65	244.20	238.34
69.5	245.05	241.10	236.06
69.6	241.33	238.45	233.78
69.7	238.81	236.32	232.09
69.8	236.73	233.81	231.03
69.9	234.61	232.25	229.56
70.0	232.87	230.96	228.78
70.1	231.12	229.80	228.13
70.2	230.20	229.43	227.71
70.3	229.18	228.57	227.38
70.4	228.97	228.24	227.37
70.5	228.34	228.13	227.79
70.6	228.90	228.70	228.27
70.7	228.52	228.65	228.63
70.8	229.46	229.52	229.96
70.9	229.90	230.40	231.44
71.0	231.03	231.61	232.78

## Typical Performance Curves

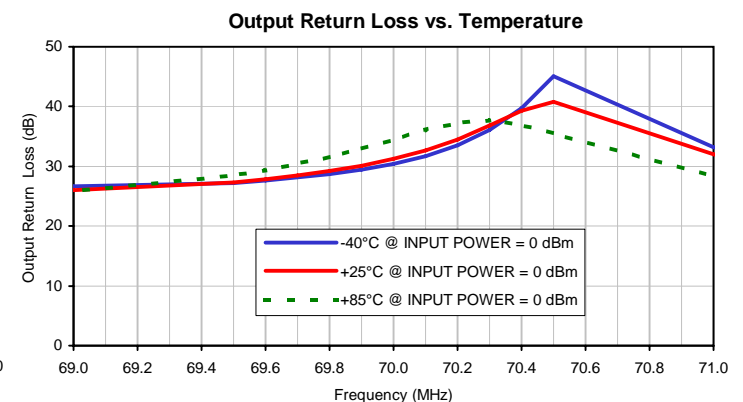
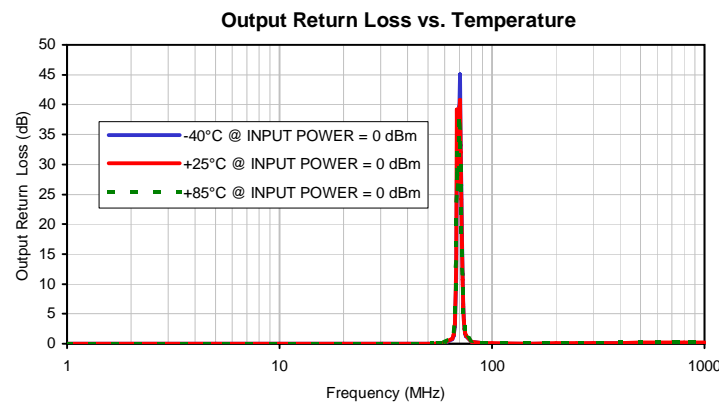
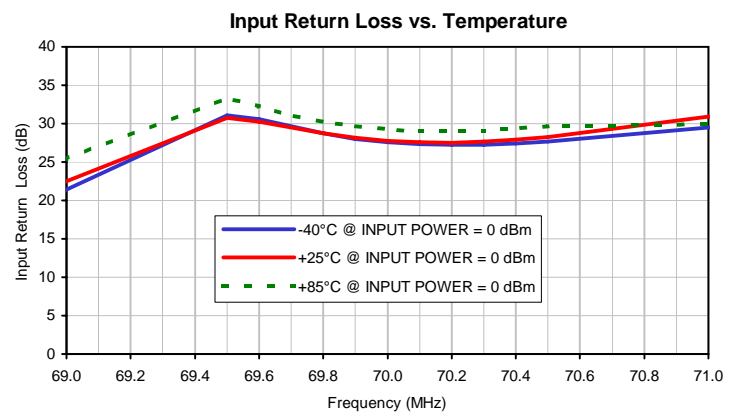
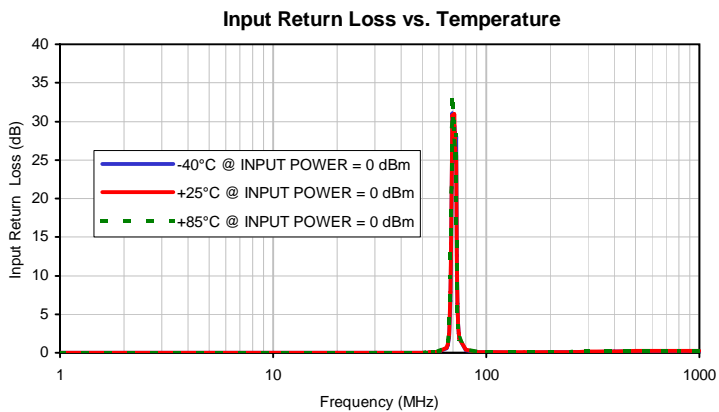
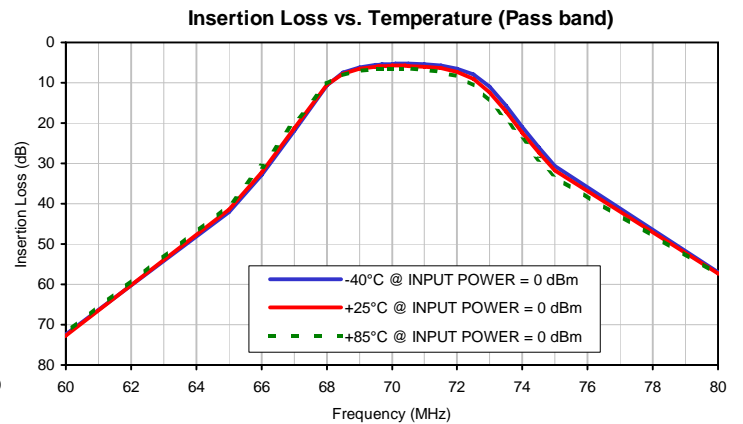
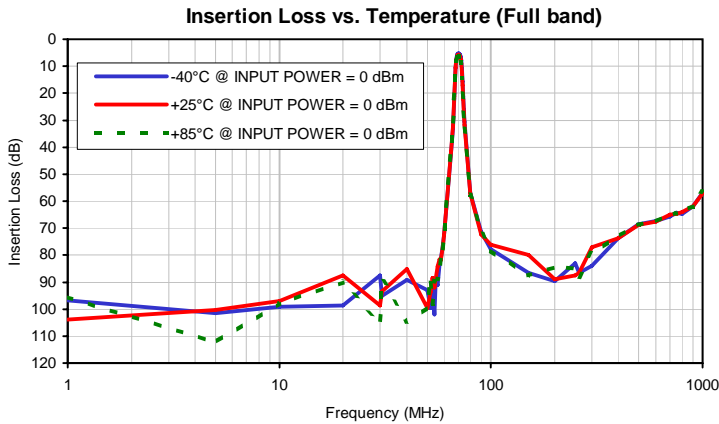

## Typical Performance Curves

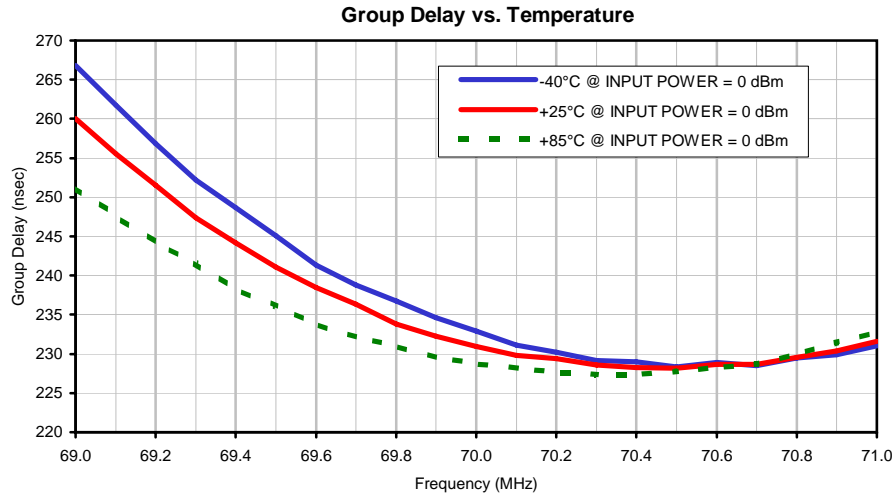

## Outline Dimensions

HU1186

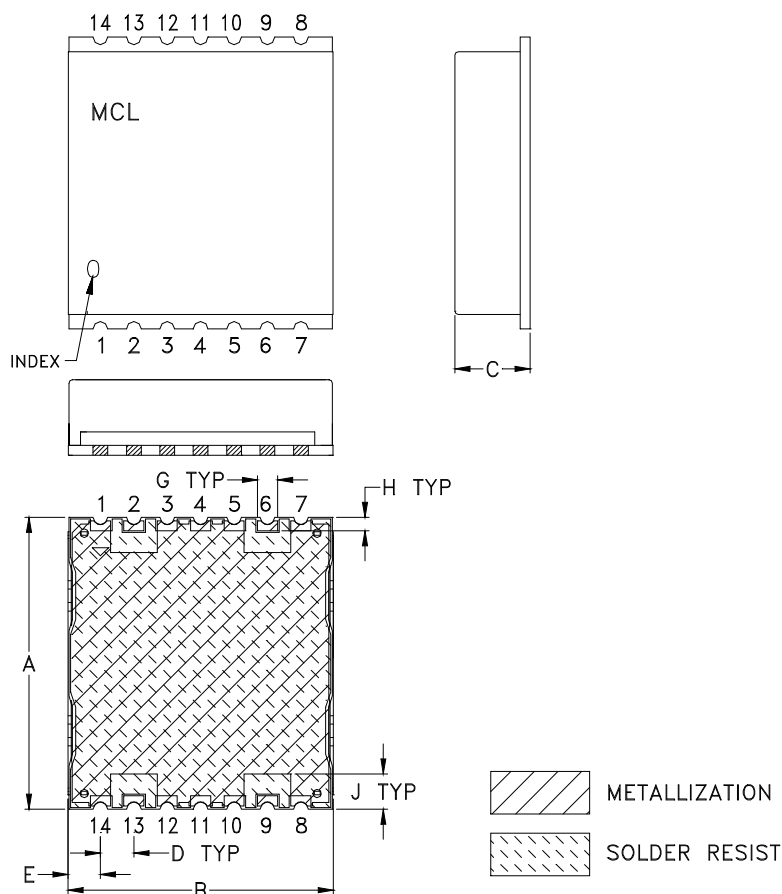

## PCB Land Pattern

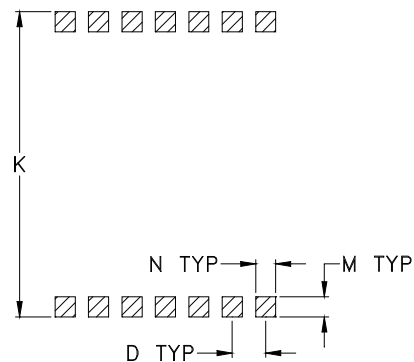

Suggested Layout,  
Tolerance to be within  $\pm 0.002$

CASE#	A	B	C	D	E	F	G	H	J	K	L	M	N	P	WT, GRAM
HU1186	.870 (22.10)	.800 (20.32)	.25 (6.35)	.100 (2.54)	.097 (2.46)	-	.060 (1.52)	.040 (1.02)	.105 (2.67)	.910 (23.11)	-	.060 (1.52)	.060 (1.52)	-	2.85

Dimensions are in inches (mm). Tolerances: 2PL. +/- .03; 3PL. +/- .015

### Notes:

- Case material: Nickel-Silver alloy.
- Base: Printed wiring laminate.
- Termination finish:  
For RoHS Case Styles: 2-5  $\mu$  inch (.05-.13 microns) Gold over 120-240  $\mu$  inch (3.05-6.10 microns) Nickel plate.  
For RoHS-5 Case Styles: Tin-Lead plate.

**Mini-Circuits**<sup>®</sup>  
ISO 9001 ISO 14001 CERTIFIED

ALL NEW  
minicircuits.com

P.O. Box 350166, Brooklyn, New York 11235-0003 (718) 934-4500 Fax (718) 332-4661 For detailed performance specs & shopping online see Mini-Circuits web site



The Design Engineers Search Engine Provides ACTUAL Data Instantly From MINI-CIRCUITS At: [www.minicircuits.com](http://www.minicircuits.com)

RF/IF MICROWAVE COMPONENTS



# Tape & Reel Packaging TR-F21

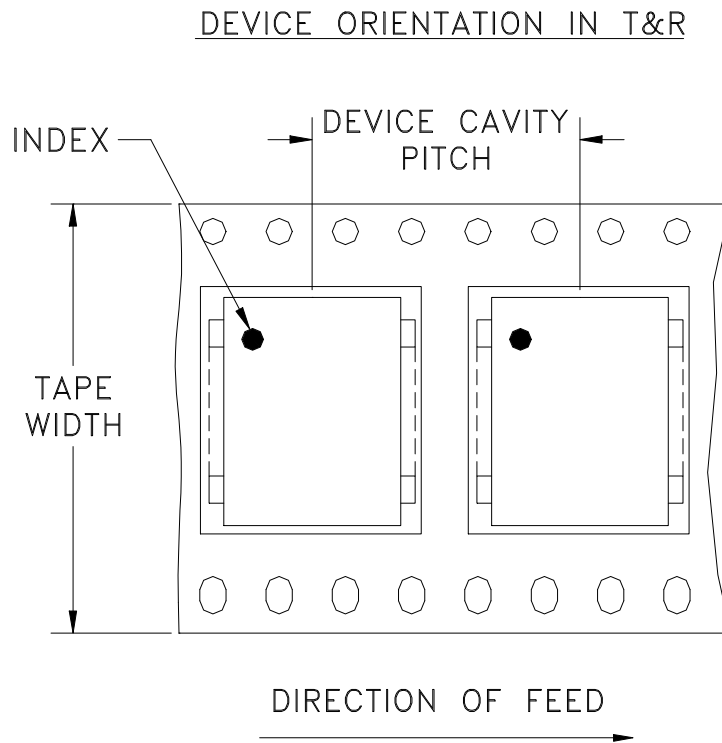

<b>Tape Width, mm</b>	<b>Device Cavity Pitch, mm</b>	<b>Reel Size, inches</b>	<b>Devices per Reel</b>
32	32	13	200

Mini-Circuits carrier tape materials provide protection from ESD (Electro-Static Discharge) during handling and transportation. Tapes are static dissipative and comply with industry standards EIA-481/EIA-541.

Go to: [www.minicircuits.com/pages/pdfs/tape.pdf](http://www.minicircuits.com/pages/pdfs/tape.pdf)



INTERNET <http://www.minicircuits.com>

P.O. Box 350166, Brooklyn, New York 11235-0003 (718) 934-4500 Fax (718) 332-4661

Distribution Centers NORTH AMERICA 800-654-7949 • 417-335-5935 • Fax 417-335-5945 • EUROPE 44-1252-832600 • Fax 44-1252-837010

Mini-Circuits ISO 9001 & ISO 14001 Certified

THIRD ANGLE PROJECTION

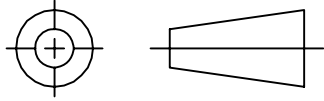

REVISIONS

REV	ECN No.	DESCRIPTION	DATE	DR	AUTH
OR	M119979	NEW RELEASE (FROM RAVON)	11/08	DK	HH
OR	R74463	NEW RELEASE (FROM RAVON)	11/08	DK	HH

**SUGGESTED MOUNTING CONFIGURATION FOR HU1186 CASE STYLE, "14FL03" PIN CODE**

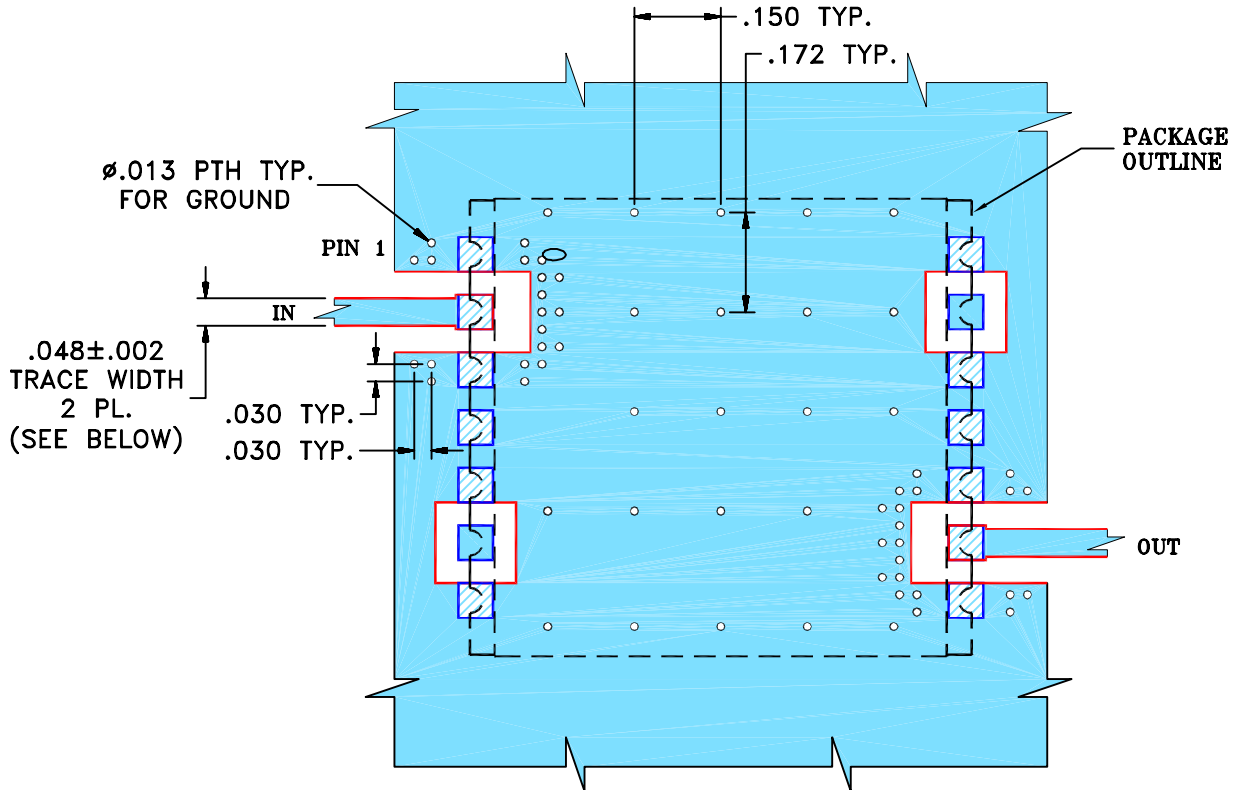

NOTES:

- TRACE WIDTH IS SHOWN FOR ROGERS R04350B, DIELECTRIC THICKNESS: .030" ± .002"; COPPER: 1/2 OZ ON EACH SIDE. FOR OTHER MATERIALS TRACE WIDTH MAY NEED TO BE MODIFIED.
- BOTTOM SIDE OF THE PCB IS CONTINUOUS GROUND PLANE.

- DENOTES PCB COPPER LAYOUT WITH SMOBC (SOLDER MASK OVER BARE COPPER)
- DENOTES COPPER LAND PATTERN FREE OF SOLDERMASK

UNLESS OTHERWISE SPECIFIED	INITIALS	DATE
DIMENSIONS ARE IN INCHES TOLERANCES ON: 2 PL DECIMALS ± 3 PL DECIMALS ± .005 ANGLES ± FRACTIONS ±	DRAWN	DK (RAVON) 02 NOV 08
	CHECKED	DH (RAVON) 02 NOV 08
	APPROVED	HH (RAVON) 02 NOV 08

**Mini-Circuits®** 13 Neptune Avenue  
Brooklyn NY 11235

PL, 14FL03, HU1186, BPF-C  
TB-500+ (50 OHM)

Mini-Circuits®  
THIS DOCUMENT AND ITS CONTENTS ARE THE PROPERTY OF MINI-CIRCUITS. EXCEPT FOR USE EXPRESSLY GRANTED, IN WRITING, TO ITS VENDORS, VENDEE AND THE UNITED STATES GOVERNMENT, MINI-CIRCUITS RESERVES ALL PROPRIETARY DESIGN, USE, MANUFACTURING AND REPRODUCTION RIGHTS THERETO. THESE CONTENTS SHALL NOT BE USED, DUPLICATED OR DISCLOSED TO ANY OUTSIDE PARTY, IN WHOLE OR IN PART, WITHOUT WRITTEN PERMISSION OF MINI-CIRCUITS.

SIZE A	CODE IDENT 15542	DRAWING NO: 98-PL-294	REV: OR
FILE: 98PL294	SCALE: 3:1	SHEET: 1 OF 1	

# Evaluation Board and Circuit

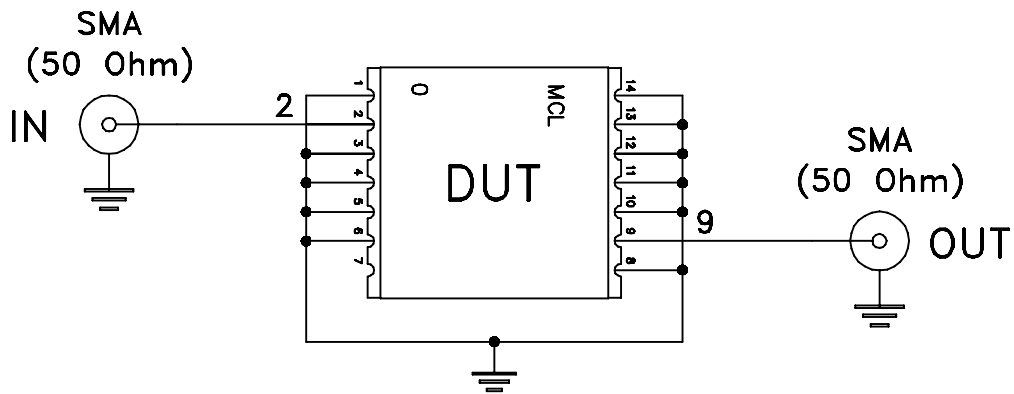
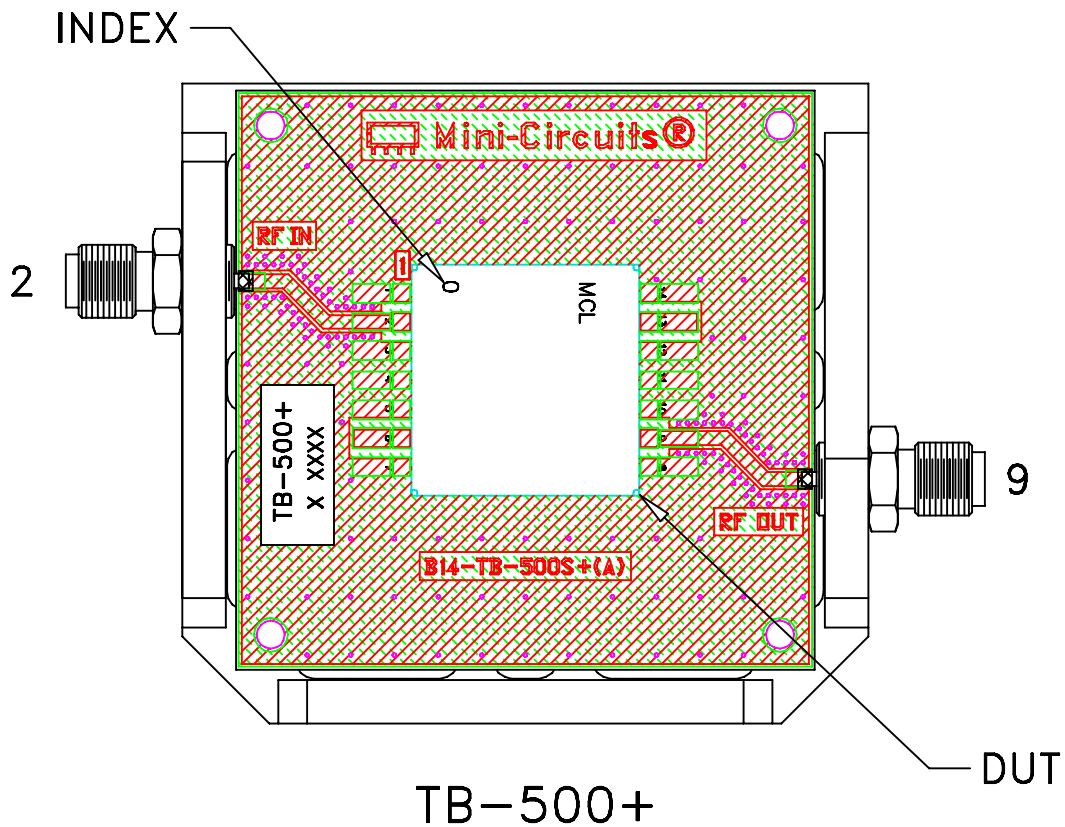

Schematic Diagram

## Notes:

1. 50 Ohm SMA Female connectors.
2. PCB Material: R04350 or equivalent.  
Dielectric Constant=3.5, Thickness=.030 inch.

 Mini-Circuits®

All Mini-Circuits products are manufactured under exacting quality assurance and control standards, and are capable of meeting published specifications after being subjected to any or all of the following physical and environmental test.

Specification	Test/Inspection Condition	Reference/Spec
Operating Temperature	-40° to 85° C Ambient Environment	Individual Model Data Sheet
Storage Temperature	-65° to 150° C Ambient Environment	Individual Model Data Sheet
Autoclave	15 psig, 100% RH, 121°C, 96 hours	JESD22-A102-C, Condition C
Temperature Cycling	-65° to 150°C, 100 cycles	JESD22-A104
Temperature Humidity	85°C/ 85% RH, 168 hours	JESD22-113
Solder Reflow Heat	Sn-Pb Eutetic Process: 240°C peak Pb-Free Process: 260°C peak	J-STD-020, Table 4-1, 4-2 and 5-2; Figure 5-1
Moisture Sensitivity: Level 1	Bake at 125°C for 24 hours Soak at 85°C/85% RH for 168 hours, Reflow 3 cycles at 240°C peak (Non-RoHS) or 260°C (RoHS)	J-STD-020
Solderability	10X magnification, 95% coverage	JESD22-B102, Method 1: Dip and Look Test
Mechanical Shock	50g, 11 ms, 1/2-sine, 18 shocks: 3 each direction, each of 3 axes	MIL-STD-202, Method 213, Condition A
Vibration (High Frequency)	20g peak, 10-2000 Hz, 12 times in each of three perpendicular directions (total 36)	MIL-STD-202, Method 204, Condition D