

Surface Mount Bandpass Filter

BPF-A60+

50Ω 55 to 65 MHz



Generic photo used for illustration purposes only

CASE STYLE: HQ1157

The Big Deal

- Low frequency 16.67% BW
- Fast roll-off
- High rejection, 40 dB from 80-900 MHz
- Miniature shielded package

Product Overview

The BPF-A60+ is a band pass filter in a shielded package (size of 0.365" x 1.360" x .35") fabricated using SMT technology. Covering 60 MHz \pm 5 MHz bandwidth, these units offer good matching within the passband and high rejection. This unit uses a miniature high Q capacitors and wire welded inductors for high reliability. In addition it has repeatable performance across production lots and consistent performance across temperature.

Key Features

Feature	Advantages
Low frequency and fractional Bandwidth 16.67%	Fast-roll-off, this will attenuate frequency closer to the passband with good rejection value of > 20 dB.
More than 40 dB rejection up to 900 MHz	This enables the filter to attenuate spurious signals and reject harmonics for a broadband of frequency.
Shielded case	Reduced interference with and from the surrounding components.

Notes

- A. Performance and quality attributes and conditions not expressly stated in this specification document are intended to be excluded and do not form a part of this specification document.
B. Electrical specifications and performance data contained in this specification document are based on Mini-Circuit's applicable established test performance criteria and measurement instructions.
C. The parts covered by this specification document are subject to Mini-Circuits standard limited warranty and terms and conditions (collectively, "Standard Terms"); Purchasers of this part are entitled to the rights and benefits contained therein. For a full statement of the Standard Terms and the exclusive rights and remedies thereunder, please visit Mini-Circuits' website at www.minicircuits.com/MCLStore/terms.jsp



Surface Mount Bandpass Filter

50Ω 55 to 65 MHz

BPF-A60+



Generic photo used for illustration purposes only

CASE STYLE: HQ1157

Features

- Fast roll-off
- High rejection, 36 dB typical
- Good VSWR 1.2:1 typical in passband
- Miniature shielded case
- Aqueous washable

Applications

- Test equipments
- Harmonic rejection
- Transmitters / receivers

Electrical Specifications at 25°C

Parameter	F#	Frequency (MHz)	Min.	Typ.	Max.	Unit	
Pass Band	Center Frequency	—	—	60	—	MHz	
	Insertion Loss	F1-F2	55-65	—	3.4	4.5	dB
	VSWR	F1-F2	55-65	—	1.5	2.2	:1
Stop Band, Lower	Insertion Loss	DC-F3	DC-50	20	36	—	dB
	VSWR	DC-F3	DC-50	—	21	—	:1
Stop Band, Upper	Insertion Loss	F4-F5	75-900	20	34	—	dB
	VSWR	F4-F5	75-900	—	30	—	:1

Maximum Ratings

Operating Temperature	-40°C to 85°C
Storage Temperature	-55°C to 100°C
RF Power Input	320mW

Permanent damage may occur if any of these limits are exceeded.

Functional Schematic

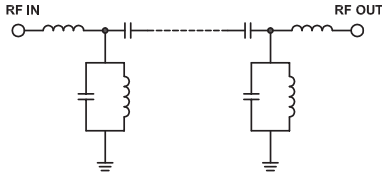

Typical Frequency Response

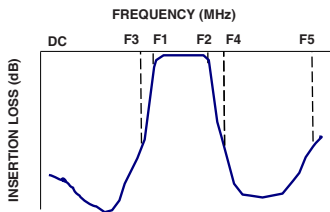

Typical Performance Data at 25°C

Frequency (MHz)	Insertion Loss (dB)	VSWR (:1)	Frequency (MHz)	Group Delay (nsec)
1.0	99.79	1737.18	55.00	158.01
45.0	77.72	108.58	55.50	161.16
47.0	65.39	69.49	56.00	164.30
50.0	43.58	27.16	56.50	161.67
51.0	34.62	16.72	57.00	159.04
52.0	24.18	8.99	57.50	148.86
53.0	12.32	3.53	58.00	138.67
54.0	5.20	1.36	58.50	131.43
55.0	3.37	1.21	59.00	124.19
60.0	2.16	1.30	59.50	119.63
65.0	2.75	1.10	60.00	115.07
66.0	3.69	1.48	60.50	112.54
67.0	5.83	2.77	61.00	110.00
69.0	13.96	10.69	61.50	108.88
72.0	26.12	27.59	62.00	107.76
75.0	35.06	44.55	63.00	108.14
100.0	64.23	133.63	63.50	109.25
250.0	98.54	133.63	64.00	110.35
500.0	67.64	82.73	64.50	110.76
900.0	60.77	66.82	65.00	111.17

+RoHS Compliant

The +Suffix identifies RoHS Compliance. See our web site for RoHS Compliance methodologies and qualifications

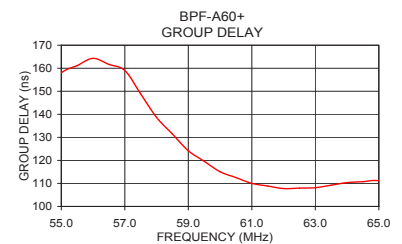
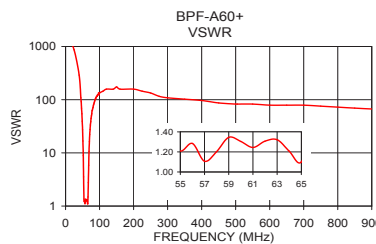
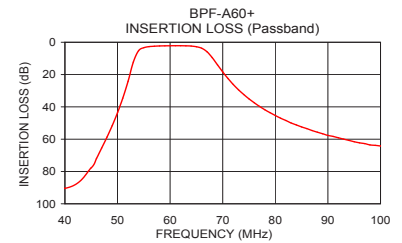
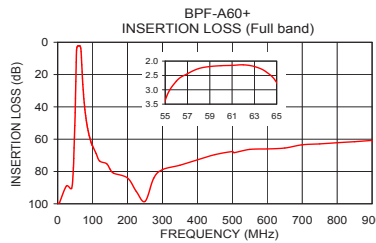

Notes

- Performance and quality attributes and conditions not expressly stated in this specification document are intended to be excluded and do not form a part of this specification document.
- Electrical specifications and performance data contained in this specification document are based on Mini-Circuit's applicable established test performance criteria and measurement instructions.
- The parts covered by this specification document are subject to Mini-Circuits standard limited warranty and terms and conditions (collectively, "Standard Terms"); Purchasers of this part are entitled to the rights and benefits contained therein. For a full statement of the Standard Terms and the exclusive rights and remedies thereunder, please visit Mini-Circuits' website at www.minicircuits.com/MCLStore/terms.jsp



Pad Connections

INPUT	1
OUTPUT	8
GROUND	2,3,4,5,6,7,9,10,11,12,13,14

Demo Board MCL P/N: TB-363+
Suggested PCB Layout (PL-227)

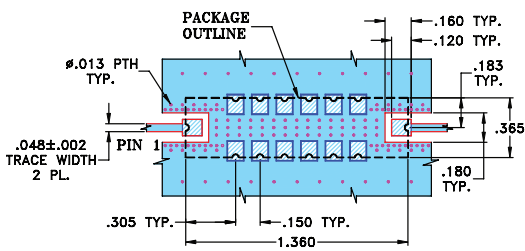

NOTE:

1. TRACE WIDTH IS SHOWN FOR FR4 WITH DIELECTRIC THICKNESS .025"±.002". COPPER: 1/2 OZ. EACH SIDE. FOR OTHER MATERIALS TRACE WIDTH MAY NEED TO BE MODIFIED.
2. BOTTOM SIDE OF THE PCB IS CONTINUOUS GROUND PLANE.

- DENOTES PCB COPPER LAYOUT WITH SMOBC (SOLDER MASK OVER BARE COPPER)
- DENOTES COPPER LAND PATTERN FREE OF SOLDERMASK

Outline Drawing

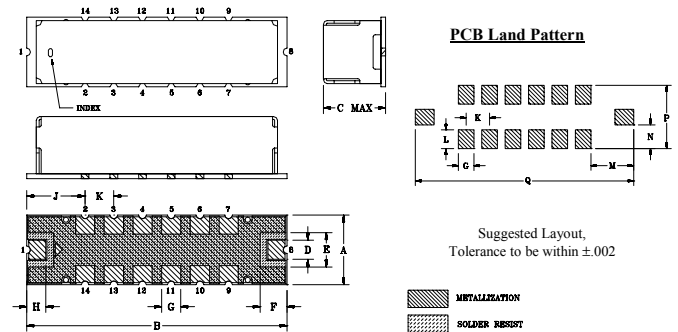

Suggested Layout,
Tolerance to be within ±.002

Outline Dimensions (inch / mm)

A	B	C	D	E	F	G	H
.365	1.360	.35	.100	.180	.140	.100	.100
9.27	34.54	8.89	2.54	4.57	3.56	2.54	2.54
J	K	L	M	N	P	Q	wt
.305	.150	.120	.275	.152	.405	1.400	grams
7.75	3.81	3.05	6.99	3.86	10.29	35.56	4.0

Note: Please refer to case style drawing for details

Notes

- A. Performance and quality attributes and conditions not expressly stated in this specification document are intended to be excluded and do not form a part of this specification document.
- B. Electrical specifications and performance data contained in this specification document are based on Mini-Circuit's applicable established test performance criteria and measurement instructions.
- C. The parts covered by this specification document are subject to Mini-Circuits standard limited warranty and terms and conditions (collectively, "Standard Terms"); Purchasers of this part are entitled to the rights and benefits contained therein. For a full statement of the Standard Terms and the exclusive rights and remedies thereunder, please visit Mini-Circuits' website at www.minicircuits.com/MCLStore/terms.jsp

Typical Performance Data

FREQ. (MHz)	INSERTION LOSS			INPUT RETURN LOSS			OUTPUT RETURN LOSS		
	(dB)			(dB)			(dB)		
	@-40°C	@+25°C	@+85°C	@-40°C	@+25°C	@+85°C	@-40°C	@+25°C	@+85°C
1.0	94.53	104.21	90.58	0.00	0.00	0.00	0.01	0.01	0.01
5.0	91.19	98.67	106.02	0.00	0.00	0.00	0.00	0.00	0.01
10.0	107.64	108.51	93.09	0.01	0.02	0.02	0.01	0.01	0.01
15.0	92.70	102.70	95.54	0.01	0.02	0.01	0.01	0.02	0.02
20.0	91.90	88.99	95.52	0.01	0.02	0.01	0.02	0.02	0.01
25.0	93.55	88.27	91.39	0.01	0.02	0.01	0.02	0.02	0.01
30.0	93.13	89.75	90.04	0.02	0.03	0.02	0.03	0.04	0.03
35.0	92.79	99.24	97.27	0.02	0.04	0.03	0.03	0.04	0.03
40.0	87.51	91.36	93.65	0.04	0.06	0.05	0.05	0.06	0.06
45.0	77.20	78.84	76.38	0.09	0.11	0.12	0.13	0.14	0.16
50.0	44.78	43.92	43.37	0.31	0.37	0.41	0.52	0.60	0.67
51.0	36.15	35.24	34.61	0.46	0.55	0.61	0.81	0.93	1.06
52.0	26.45	25.46	24.80	0.77	0.91	1.04	1.43	1.67	1.90
53.0	15.63	14.70	14.15	1.77	2.15	2.48	3.18	3.79	4.35
54.0	6.41	6.14	6.09	6.93	8.29	9.32	9.56	11.03	12.18
55.0	3.27	3.44	3.62	30.20	26.88	24.39	19.60	19.87	19.85
56.0	2.68	2.86	3.04	15.58	15.75	15.95	16.14	16.35	16.54
57.0	2.35	2.52	2.68	17.99	19.40	20.51	17.58	18.56	19.20
58.0	2.12	2.31	2.47	31.18	28.76	27.18	23.99	23.45	22.82
59.0	2.05	2.23	2.40	18.88	18.79	18.85	18.92	18.92	19.07
60.0	2.00	2.17	2.33	18.09	18.86	19.44	19.04	20.14	21.19
61.0	1.98	2.15	2.32	22.10	22.54	22.41	29.88	36.91	42.90
62.0	2.01	2.20	2.38	19.85	19.19	18.71	23.09	21.59	20.66
63.0	2.10	2.30	2.48	16.63	16.68	16.76	17.32	17.22	17.18
64.0	2.21	2.41	2.60	16.86	17.49	18.00	17.46	18.15	18.75
65.0	2.37	2.62	2.84	18.81	19.45	19.86	23.68	26.83	30.86
66.0	2.86	3.21	3.54	15.91	15.52	15.23	18.33	16.90	15.89
67.0	4.38	4.99	5.50	9.21	8.74	8.48	8.44	7.76	7.33
68.0	7.78	8.63	9.28	4.62	4.46	4.39	3.77	3.54	3.42
69.0	12.45	13.34	14.00	2.52	2.51	2.54	1.90	1.87	1.86
70.0	17.22	18.05	18.63	1.60	1.65	1.68	1.17	1.18	1.21
71.0	21.58	22.32	22.86	1.14	1.20	1.24	0.83	0.86	0.89
72.0	25.49	26.12	26.57	0.88	0.93	0.98	0.64	0.67	0.71
73.0	28.93	29.50	29.91	0.71	0.75	0.79	0.53	0.57	0.60
74.0	32.04	32.56	32.92	0.59	0.64	0.67	0.45	0.48	0.51
75.0	34.82	35.25	35.62	0.51	0.56	0.59	0.39	0.41	0.44
100.0	64.69	65.63	64.84	0.12	0.15	0.16	0.11	0.13	0.15
150.0	78.67	80.02	77.52	0.07	0.11	0.11	0.07	0.10	0.11
200.0	82.80	82.91	82.30	0.06	0.11	0.12	0.07	0.10	0.12
300.0	83.27	84.22	89.88	0.09	0.14	0.15	0.09	0.11	0.13
305.0	85.13	82.47	85.90	0.09	0.13	0.15	0.09	0.12	0.14
350.0	81.88	75.59	78.88	0.11	0.15	0.17	0.10	0.13	0.15
400.0	75.12	75.59	74.79	0.11	0.16	0.18	0.10	0.14	0.16
450.0	72.89	73.72	73.77	0.13	0.18	0.19	0.12	0.15	0.17
500.0	70.35	71.19	71.37	0.13	0.19	0.20	0.13	0.16	0.19
550.0	69.16	69.44	70.41	0.15	0.20	0.21	0.14	0.17	0.20
600.0	68.57	68.45	68.80	0.15	0.21	0.23	0.15	0.19	0.22
650.0	68.36	67.70	68.62	0.16	0.22	0.23	0.16	0.19	0.22
700.0	68.36	67.18	68.46	0.15	0.22	0.23	0.16	0.20	0.23
750.0	68.30	68.43	68.68	0.17	0.23	0.25	0.17	0.22	0.25
800.0	58.62	64.00	57.53	0.18	0.23	0.26	0.17	0.22	0.26
850.0	64.93	64.45	64.34	0.18	0.24	0.26	0.17	0.22	0.26
900.0	66.77	66.36	66.42	0.19	0.25	0.28	0.20	0.25	0.29
950.0	67.02	65.14	66.79	0.19	0.26	0.29	0.19	0.27	0.31
1000.0	65.81	65.96	64.07	0.22	0.28	0.32	0.21	0.29	0.34

Typical Performance Data

FREQ. (MHz)	GROUP DELAY		
	(nsec)		
	@-40°C	@+25°C	@+85°C
50.0	47.47	51.10	53.99
51.0	75.94	80.17	81.83
52.0	105.35	108.35	109.20
53.0	126.45	128.43	129.26
54.0	142.42	143.61	144.21
55.0	154.34	154.88	155.04
56.0	161.26	161.01	160.59
57.0	159.87	158.39	157.04
58.0	145.10	142.74	141.04
59.0	127.12	125.74	124.79
60.0	116.57	115.87	115.37
61.0	110.58	110.22	110.01
62.0	107.39	107.37	107.40
63.0	107.20	107.56	107.86
64.0	109.96	110.46	110.70
65.0	112.49	112.46	112.26
66.0	111.57	110.87	110.20
67.0	106.72	105.56	104.54
68.0	98.98	97.47	96.18
69.0	88.81	86.86	85.35
70.0	75.98	73.73	71.96

Typical Performance Curves

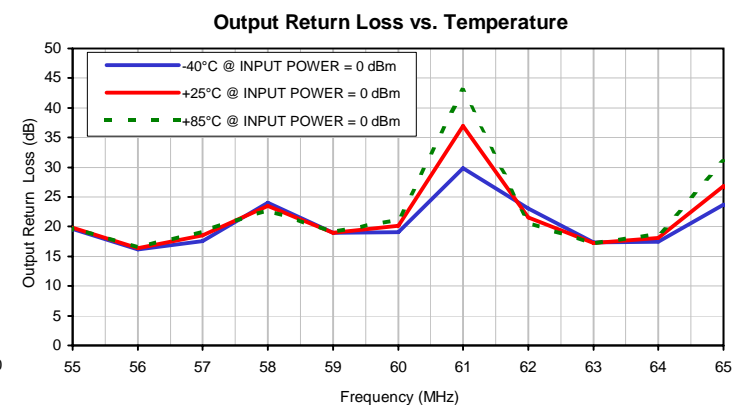
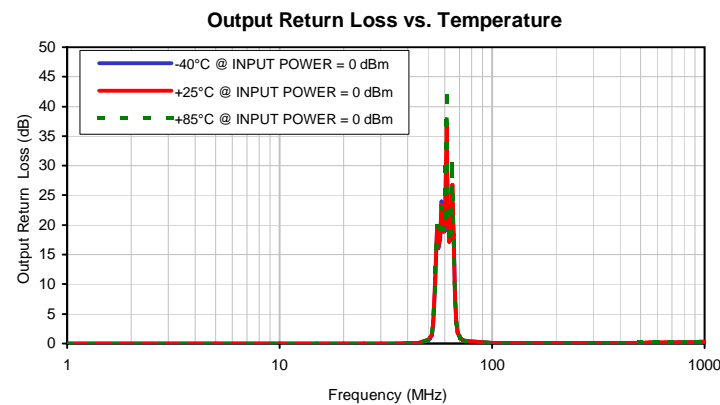
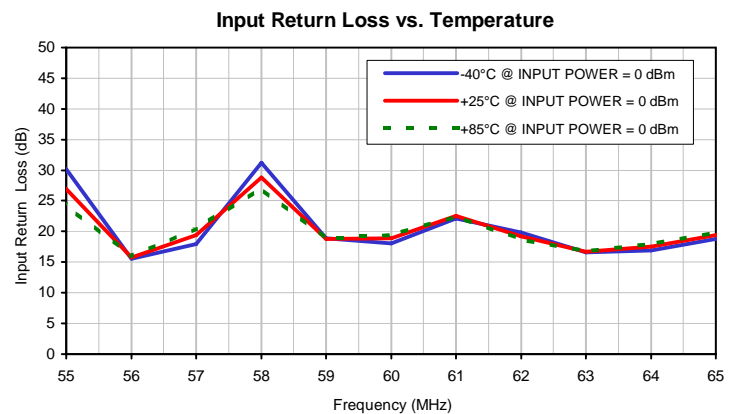
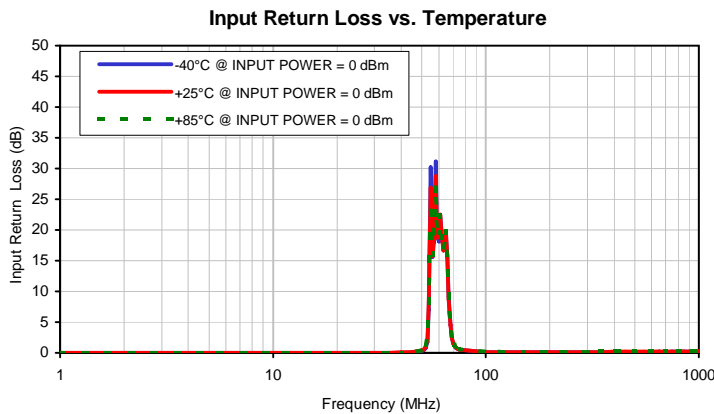
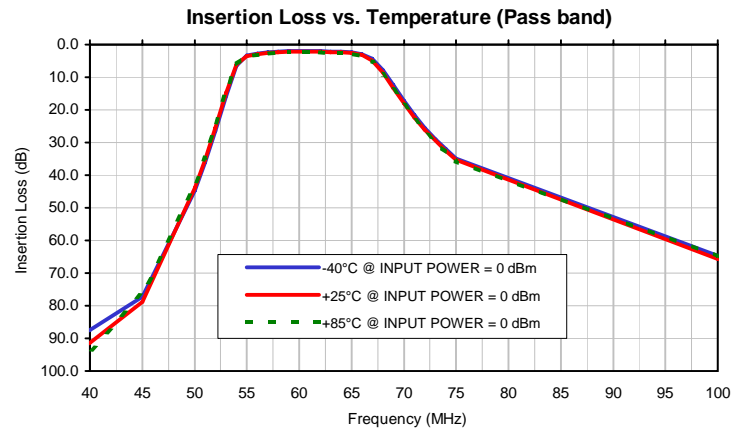
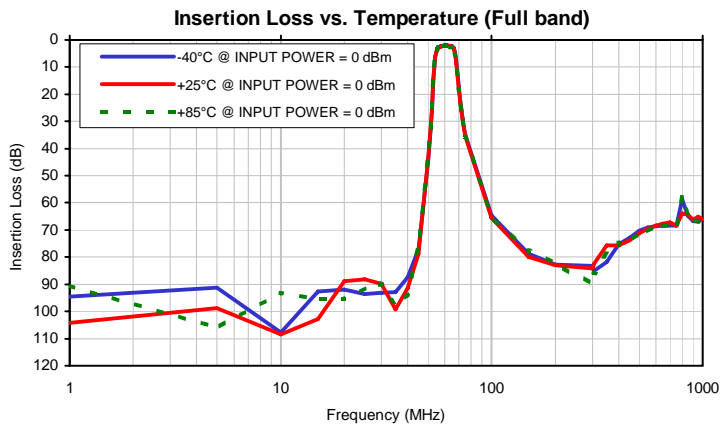

Typical Performance Curves

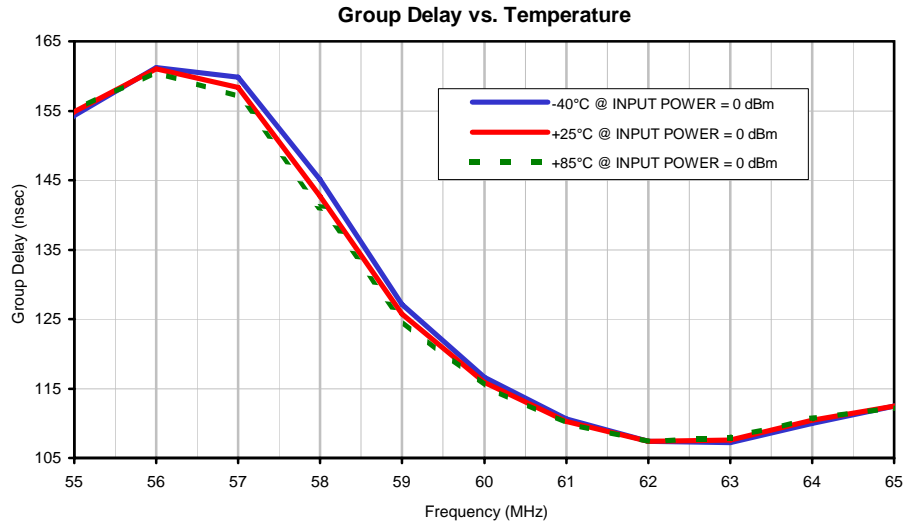

Case Style

HQ

Outline Dimensions

HQ1157

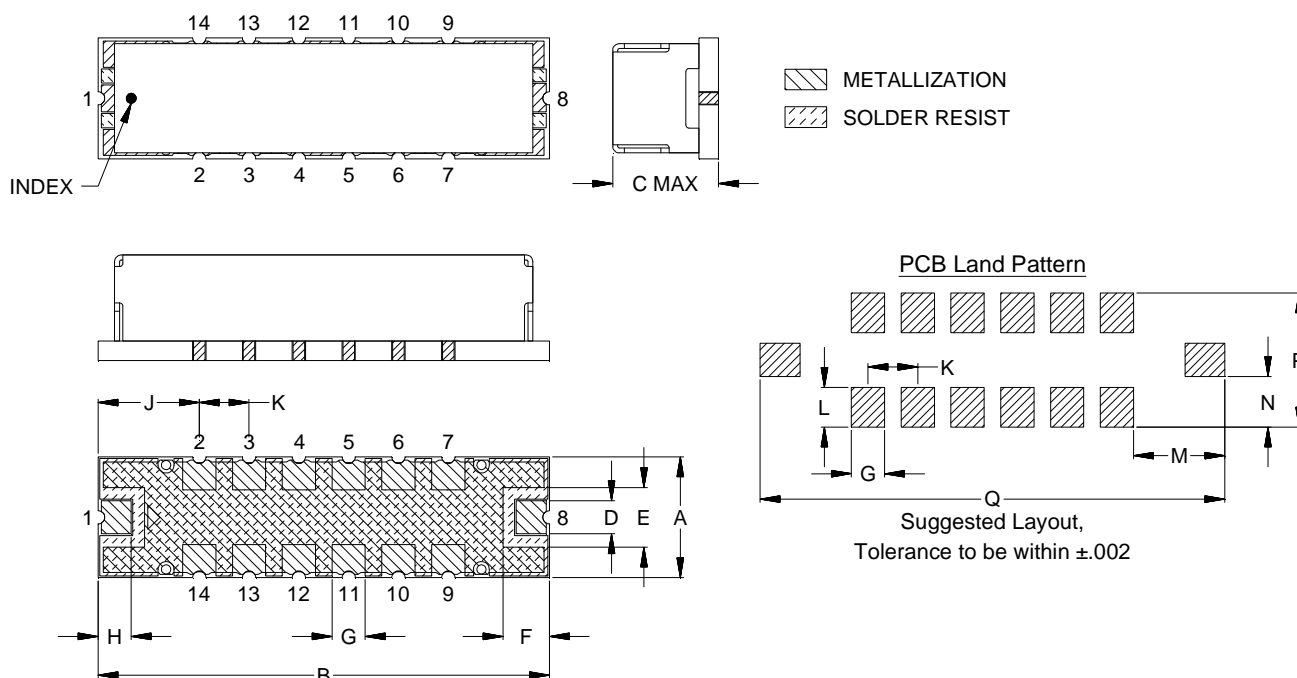

CASE#	A	B	C	D	E	F	G	H	J	K	L	M
HQ1157	.365 (9.27)	1.360 (34.54)	.350 (8.89)	.100 (2.54)	.180 (4.57)	.140 (3.56)	.100 (2.54)	.100 (2.54)	.305 (7.75)	.150 (3.81)	.120 (3.05)	.275 (6.99)

CASE#	N	P	Q	WT.GRAM
HQ1157	.152 (3.87)	.405 (10.29)	1.400 (35.56)	4.0

Dimensions are in inches (mm). Tolerances: 2Pl. ± .03; 3Pl. ± .015

Notes:

- Case material: Nickel-Silver alloy.
- Base: Printed wiring laminate.
- Termination finish:
 - For RoHS Case Styles: 3-5 μ inch (.08-.13 microns) Gold over 120-240 μ inch (3.05-6.10 microns) Nickel plate.
 - For RoHS-5 Case Styles: Tin-Lead plate.

Mini-Circuits®
ISO 9001 ISO 14001 CERTIFIED

ALL NEW
minicircuits.com

P.O. Box 350166, Brooklyn, New York 11235-0003 (718) 934-4500 Fax (718) 332-4661 For detailed performance specs & shopping online see Mini-Circuits web site



The Design Engineers Search Engine Provides ACTUAL Data Instantly From MINI-CIRCUITS At: www.minicircuits.com

RF/IF MICROWAVE COMPONENTS

Tape & Reel Packaging TR-F83

DEVICE ORIENTATION IN T&R

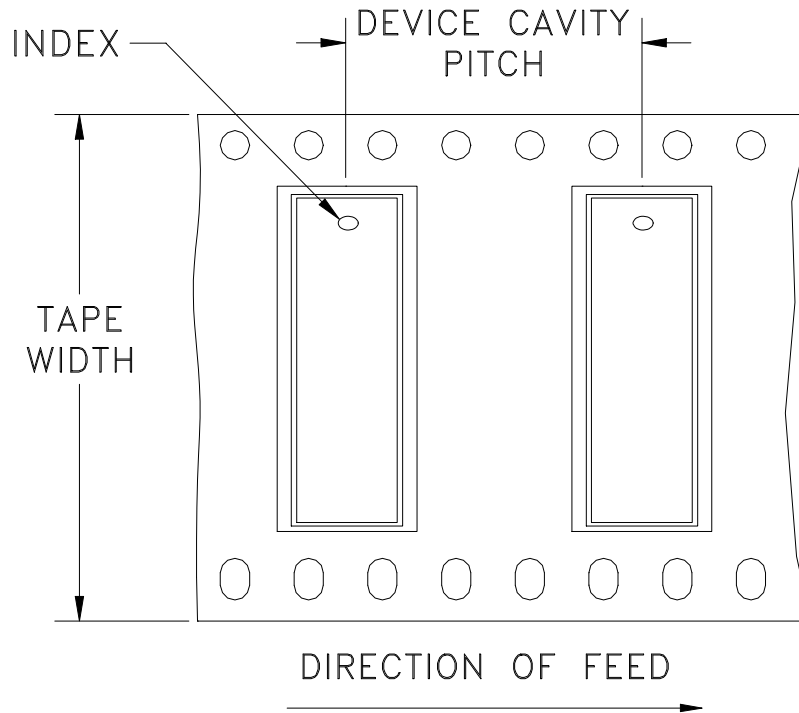

Tape Width, mm	Device Cavity Pitch, mm	Reel Size, inches	Devices per Reel
56	16	13	100

Mini-Circuits carrier tape materials provide protection from ESD (Electro-Static Discharge) during handling and transportation. Tapes are static dissipative and comply with industry standards EIA-481/EIA-541.

Go to: www.minicircuits.com/pages/pdfs/tape.pdf



INTERNET <http://www.minicircuits.com>

P.O. Box 350166, Brooklyn, New York 11235-0003 (718) 934-4500 Fax (718) 332-4661

Distribution Centers NORTH AMERICA 800-654-7949 • 417-335-5935 • Fax 417-335-5945 • EUROPE 44-1252-832600 • Fax 44-1252-837010

Mini-Circuits ISO 9001 & ISO 14001 Certified

THIRD ANGLE PROJECTION

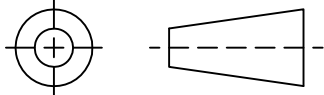

REVISIONS

REV	ECN No.	DESCRIPTION	DATE	DR	AUTH
OR	M101212	NEW RELEASE (FROM RAVON)	11/05	DK	YB
A	M108938	SWITCH HATCHES	12/06	DK	HH
B	M118075	CHANGE LINE PLACES	06/08	HB	HH
C	M173459	CORRECTED CASE STYLE & TB PART#	03/27/19	ITG	IL

**SUGGESTED MOUNTING CONFIGURATION
FOR HQ1157 CASE STYLE, rf PIN CONNECTION**

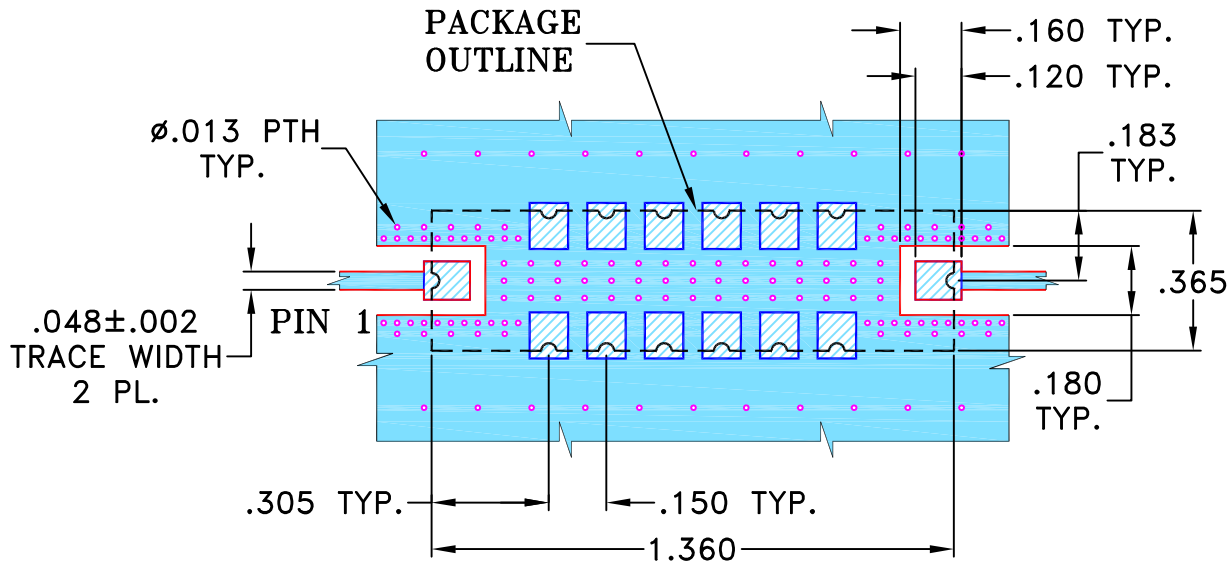

NOTE:

1. TRACE WIDTH IS SHOWN FOR FR4 WITH DIELECTRIC THICKNESS .025" ± .002". COPPER: 1/2 OZ. EACH SIDE. FOR OTHER MATERIALS TRACE WIDTH MAY NEED TO BE MODIFIED.
2. BOTTOM SIDE OF THE PCB IS CONTINUOUS GROUND PLANE.

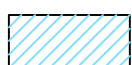
-  DENOTES PCB COPPER LAYOUT WITH SMOBC (SOLDER MASK OVER BARE COPPER)
-  DENOTES COPPER LAND PATTERN FREE OF SOLDERMASK

UNLESS OTHERWISE SPECIFIED	INITIALS	DATE
DIMENSIONS ARE IN INCHES	DRAWN HB (RAVON)	12 JUN 2008
TOLERANCES ON:	CHECKED RZ (RAVON)	12 JUN 2008
2 PL DECIMALS ±	APPROVED HH (RAVON)	12 JUN 2008
3 PL DECIMALS ± .005		
ANGLES ±		
FRACTIONS ±		

 **Mini-Circuits®** 13 Neptune Avenue
Brooklyn NY 11235

PL, rf, HQ1157, TB-363+, 50 OHM

SIZE A	CODE IDENT 15542	DRAWING NO: 98-PL-227	REV: C
FILE: 98PL227	SCALE: 2:1	SHEET: 1 OF 1	

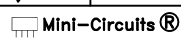
 Mini-Circuits®
THIS DOCUMENT AND ITS CONTENTS ARE THE PROPERTY OF MINI-CIRCUITS. EXCEPT FOR USE EXPRESSLY GRANTED, IN WRITING, TO ITS VENDORS, VENDEE AND THE UNITED STATES GOVERNMENT, MINI-CIRCUITS RESERVES ALL PROPRIETARY DESIGN, USE, MANUFACTURING AND REPRODUCTION RIGHTS THERETO. THESE CONTENTS SHALL NOT BE USED, DUPLICATED OR DISCLOSED TO ANY OUTSIDE PARTY, IN WHOLE OR IN PART, WITHOUT WRITTEN PERMISSION OF MINI-CIRCUITS.

Evaluation Board and Circuit

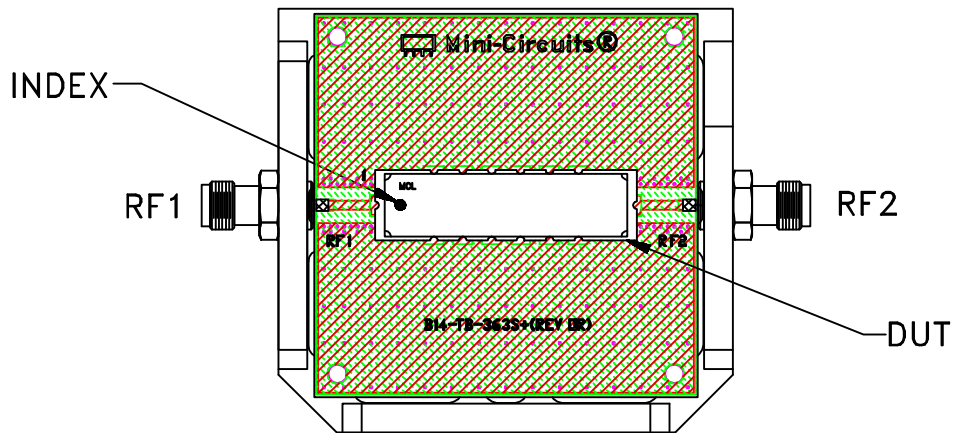

TB-363+

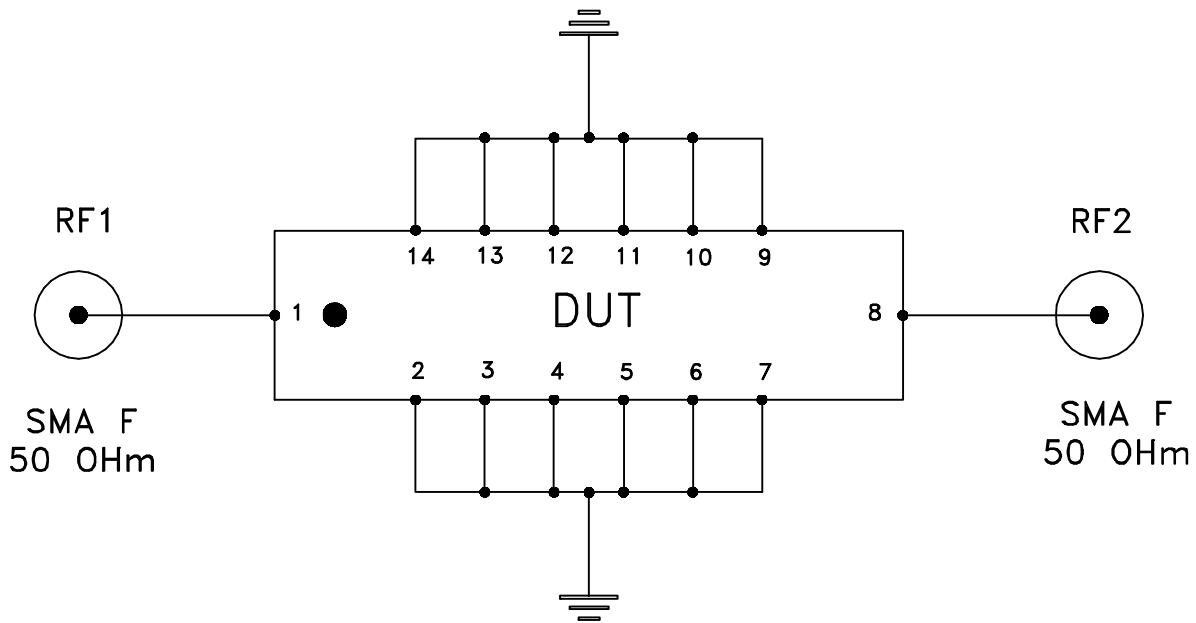

Schematic Diagram

Notes:

1. 50 Ohm SMA Female connectors.
2. PCB Material: ROGERS R04350 or equivalent,
Dielectric Constant=3.48, Thickness=.030 inch.

 **Mini-Circuits®**

All Mini-Circuits products are manufactured under exacting quality assurance and control standards, and are capable of meeting published specifications after being subjected to any or all of the following physical and environmental test.

Specification	Test/Inspection Condition	Reference/Spec
Operating Temperature	-40° to 85° C Ambient Environment	Individual Model Data Sheet
Storage Temperature	-65° to 150° C Ambient Environment	Individual Model Data Sheet
Autoclave	15 psig, 100% RH, 121°C, 96 hours	JESD22-A102-C, Condition C
Temperature Cycling	-65° to 150°C, 100 cycles	JESD22-A104
Temperature Humidity	85°C/ 85% RH, 168 hours	JESD22-113
Solder Reflow Heat	Sn-Pb Eutetic Process: 240°C peak Pb-Free Process: 260°C peak	J-STD-020, Table 4-1, 4-2 and 5-2; Figure 5-1
Moisture Sensitivity: Level 1	Bake at 125°C for 24 hours Soak at 85°C/85% RH for 168 hours, Reflow 3 cycles at 240°C peak (Non-RoHS) or 260°C (RoHS)	J-STD-020
Solderability	10X magnification, 95% coverage	JESD22-B102, Method 1: Dip and Look Test
Mechanical Shock	50g, 11 ms, 1/2-sine, 18 shocks: 3 each direction, each of 3 axes	MIL-STD-202, Method 213, Condition A
Vibration (High Frequency)	20g peak, 10-2000 Hz, 12 times in each of three perpendicular directions (total 36)	MIL-STD-202, Method 204, Condition D