



COAXIAL

DC Block

BLK-V54+

50Ω 10 MHz to 50 GHz 2.4mm-Female to 2.4mm-Male

THE BIG DEAL

- Ultra-wideband, 10MHz to 50 GHz
- Flat Response
- Low Insertion Loss, 0.50 dB typ
- Mates with 1.85 mm and V connectors



Generic photo used for illustration purposes only

APPLICATIONS

- Test and Measurement Instrumentation
- Communication Systems
- Defense Systems

Model No.	BLK-V54+
Case Style	DJ2264
Connectors	2.4mm-F to 2.4mm-M

+RoHS Compliant

The +Suffix identifies RoHS Compliance. See our website for methodologies and qualifications

PRODUCT OVERVIEW

Mini-Circuits' BLK-V54+ is a coaxial DC Block supporting a wide range of applications from .010 to 50GHz including 5G systems, Ka-Band SatCom, test and measurement and more. This model provides low insertion loss, excellent return loss, RF input handling up to 1 watts and DC voltage handling up to 100V. The unit features 2.4mm-Female connector at one end and 2.4mm-Male connector at the other end and comes housed in a rugged stainless steel body, measuring only 0.36" in diameter and 0.87" in length.

KEY FEATURES

Features	Advantages
Wideband, 10 MHz to 50 GHz	Wide frequency range up to 50 GHz provides application flexibility and makes this model ideal for broad-band and multi-band use.
Excellent Return Loss, 23dB typ	Provides good matching for 50Ω systems and minimizes signal reflections across wide frequency range enabling its use in test and measurement.
Low Insertion Loss, 0.50 dB typ.	Provides excellent signal power transmission from input to output.
Passivated stainless steel construction.	Stands up to wear and tear in demanding test environments and provides excellent reliability.
Wide operating temperature range, -35 to +85 °C	Withstands wide operating conditions.



COAXIAL

DC Block

BLK-V54+

Mini-Circuits

50Ω 10 MHz to 50 GHz 2.4mm-Female to 2.4mm-Male

ELECTRICAL SPECIFICATIONS AT 25°C

Parameter	Frequency (GHz)	Min.	Typ.	Max.	Units
Frequency Range		0.01		50	GHz
Insertion Loss	0.01-40	—	0.41	1.0	dB
	40-50	—	0.51	1.25	
Return Loss	0.01-40	12.2	23	—	dB
	40-50	12.2	23	—	

ABSOLUTE MAXIMUM RATINGS

Parameter	Ratings
Operating Case Temperature	-35 °C to +85 °C
Storage Temperature	-35 °C to +85 °C
DC Input Voltage	100 V
Input Power	30 dBm

Permanent damage may occur if any of these limits are exceeded.

ELECTRICAL SCHEMATIC

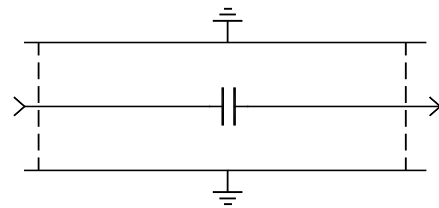



COAXIAL

DC Block

BLK-V54+

Mini-Circuits

50Ω 10 MHz to 50 GHz 2.4mm-Female to 2.4mm-Male

COAXIAL CONNECTIONS

Port 1	2.4mm-Female
Port 2	2.4mm-Male

OUTLINE DRAWING

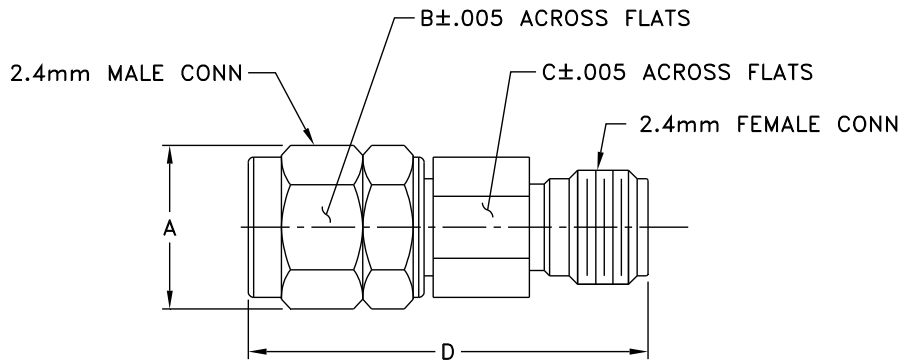

OUTLINE DIMENSIONS (Inches) mm

A	B	C	D	E	wt
0.360	0.312	0.281	0.871	--	grams
9.14	7.93	7.14	22.12	--	5.44



COAXIAL

DC Block

BLK-V54+

Mini-Circuits

50Ω 10 MHz to 50 GHz 2.4mm-Female to 2.4mm-Male

TYPICAL PERFORMANCE DATA AND CHARTS

Frequency (MHz)	Insertion Loss (dB)	Return Loss (dB)	
		2.4mm-Female	2.4mm-Male
10	0.02	44.5	44.6
100	0.02	48.2	47.9
500	0.05	35.3	35.3
1000	0.08	29.7	29.7
10000	0.33	26.9	35.0
20000	0.42	18.6	18.5
31000	0.47	20.3	23.9
41000	0.51	22.2	20.6
45000	0.52	27.3	27.8
50000	0.54	23.3	21.0

BLK-V54+
INSERTION LOSS

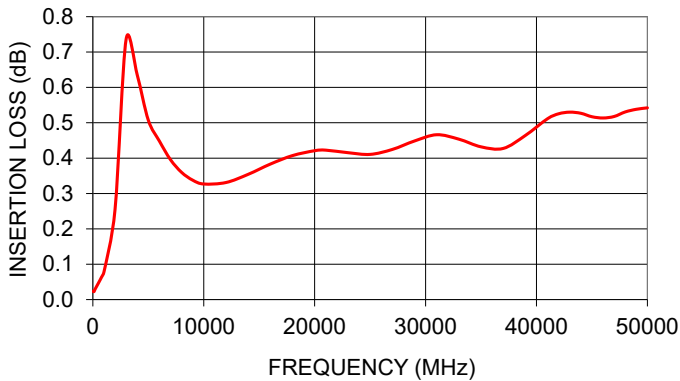

BLK-V54+
RETURN LOSS

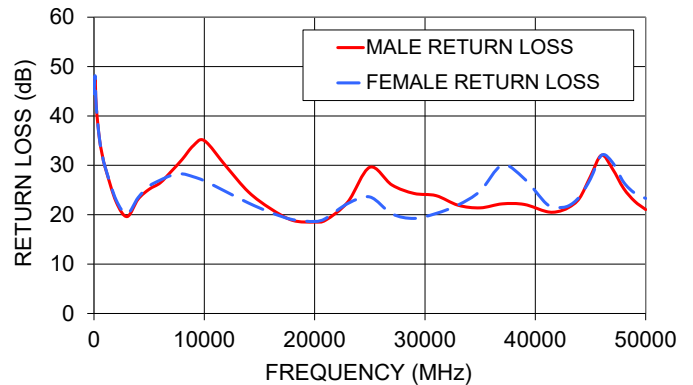

NOTES

- A. Performance and quality attributes and conditions not expressly stated in this specification document are intended to be excluded and do not form a part of this specification document.
- B. Electrical specifications and performance data contained in this specification document are based on Mini-Circuit's applicable established test performance criteria and measurement instructions.
- C. The parts covered by this specification document are subject to Mini-Circuits standard limited warranty and terms and conditions (collectively, "Standard Terms"); Purchasers of this part are entitled to the rights and benefits contained therein. For a full statement of the standard terms and the exclusive rights and remedies thereunder, please visit Mini-Circuits' website at www.minicircuits.com/terms/viewterm.html



Typical Performance Data

FREQUENCY (GHz)	INSERTION LOSS (dB)	2.4mm-FEMALE Return Loss (dB)	2.4mm-MALE Return Loss (dB)
0.01	0.02	44.5	44.6
0.10	0.02	48.2	47.9
0.20	0.03	42.1	42.1
0.50	0.05	35.3	35.3
0.80	0.06	31.6	31.6
1.00	0.08	29.7	29.7
2.00	0.25	23.0	22.6
3.00	0.74	20.2	19.6
4.00	0.64	23.5	23.2
5.00	0.51	25.8	25.2
6.00	0.45	27.0	26.5
7.00	0.40	27.9	28.8
8.00	0.36	28.3	31.2
9.00	0.34	27.7	34.0
10.00	0.33	26.9	35.0
12.00	0.33	24.6	29.7
14.00	0.35	22.4	24.6
16.00	0.38	20.5	21.2
18.00	0.41	19.0	18.9
20.00	0.42	18.6	18.5
21.00	0.42	19.2	18.9
23.00	0.42	22.3	22.6
25.00	0.41	23.6	29.6
27.00	0.42	20.2	26.0
29.00	0.45	19.3	24.3
31.00	0.47	20.3	23.9
33.00	0.45	22.0	21.9
35.00	0.43	24.8	21.4
37.00	0.43	30.0	22.2
39.00	0.46	27.3	22.1
41.00	0.51	22.2	20.6
42.00	0.53	21.5	20.6
43.00	0.53	21.8	21.4
44.00	0.53	23.6	23.3
45.00	0.52	27.3	27.8
46.00	0.51	32.0	32.0
47.00	0.52	30.6	29.3
48.00	0.53	26.6	25.3
49.00	0.54	24.4	22.7
50.00	0.54	23.3	21.0

Typical Performance Curves

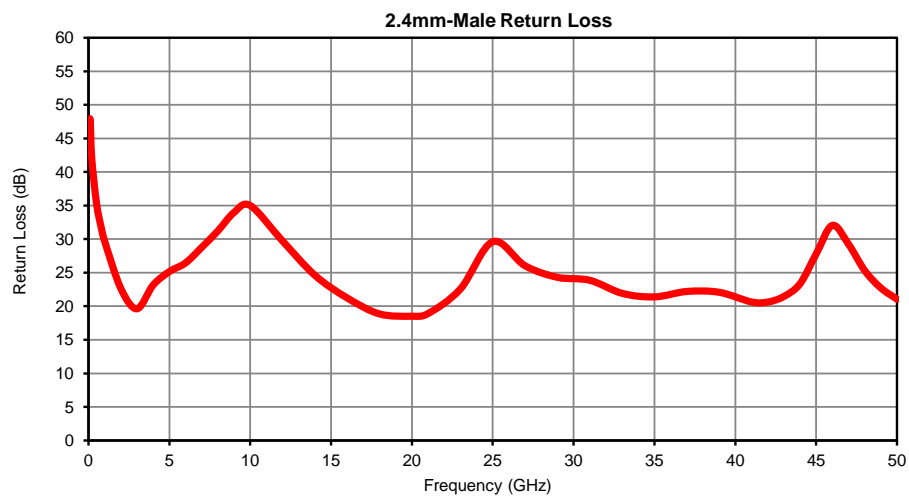
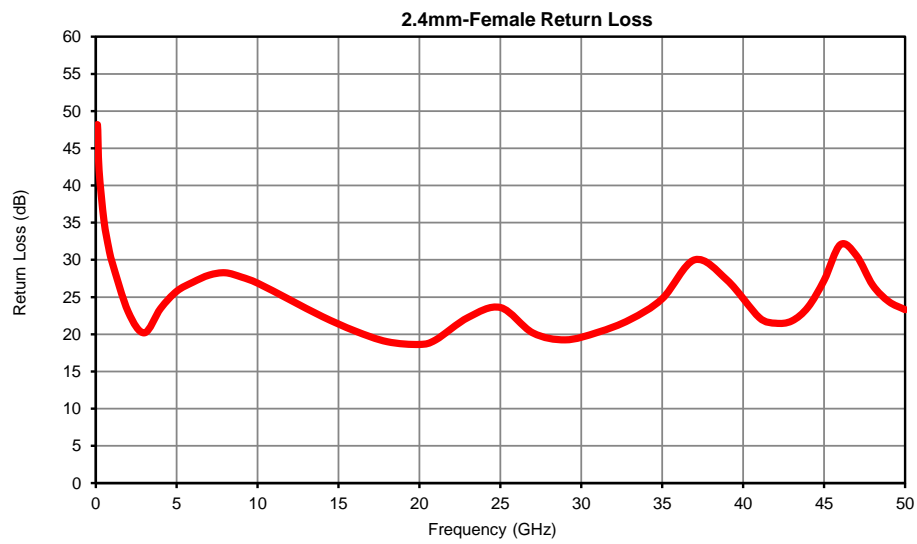
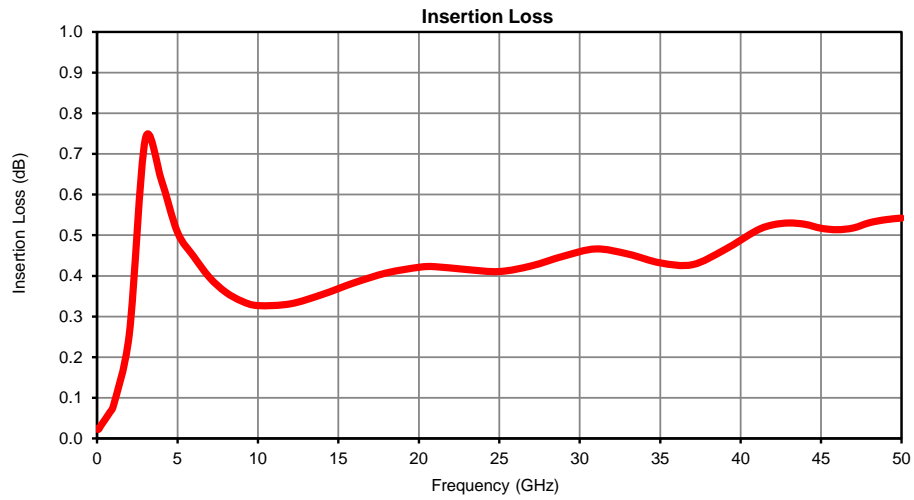

Outline Dimensions

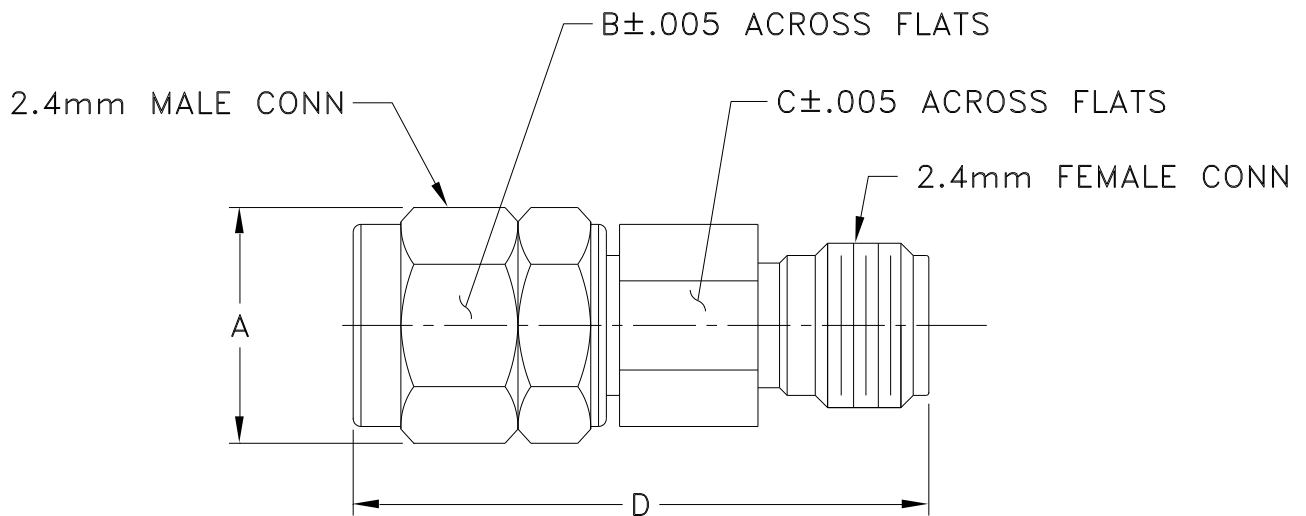

CASE #	A	B	C	D	E	WT. GRAM
DJ2264	.36 (9.14)	.312 (7.93)	.281 (7.14)	.871 (22.12)	-- --	5.44

Dimensions are in inches (mm). Tolerances: 2 Pl. $\pm .030$; 3Pl. $\pm .015$

Notes:

1. Case material:Stainless Steel.
2. Finish: Passivation.



All Mini-Circuits products are manufactured under exacting quality assurance and control standards, and are capable of meeting published specifications after being subjected to any or all of the following physical and environmental test.

Specification	Test/Inspection Condition	Reference/Spec
Operating Temperature	-35° to 85°C Ambient Environment	Individual Model Data Sheet
Storage Temperature	-35° to 85°C Ambient Environment	Individual Model Data Sheet
Thermal Shock	-35° to 85°C, 5 cycles	MIL-STD-202, Method 107, Condition B
Connector Durability	500 Mating / Unmating Cycles	MIL-PRF-390 / 2E, Paragraph 4, 6, 12