

Ceramic

# Bandpass Filter

**BFTC-618+**

50Ω 460 to 776 MHz

## The Big Deal

- LTCC construction
- Temperature stable from -40°C to +85°C
- Small size (0.150 x 0.150 x 0.059")



*Generic photo used for illustration purposes only*  
CASE STYLE: FR933-1

## Product Overview

The BFTC-618+ LTCC bandpass filter covers the 460 to 776 MHz passband with 25 dB upper/lower stopband rejection. This model handles up to 3W RF input power and provides a wide operating temperature range from -40 to +85°C. Utilizing LTCC multi-layer construction, the filter achieves excellent repeatability of performance and comes in a tiny ceramic package saving space in dense PCB layouts.

## Key Features

Feature	Advantages
LTCC Construction	Provides a rugged package well suited for tough environments such as high humidity and temperature extremes.
Tiny size (0.150 x 0.150 x 0.059")	Saves space in dense circuit boards and minimizes the effects of parasitics.
Wide operating temperature range, -40 to +85°C	Enables reliable performance in extreme environments

### Notes

- A. Performance and quality attributes and conditions not expressly stated in this specification document are intended to be excluded and do not form a part of this specification document.  
B. Electrical specifications and performance data contained in this specification document are based on Mini-Circuit's applicable established test performance criteria and measurement instructions.  
C. The parts covered by this specification document are subject to Mini-Circuits standard limited warranty and terms and conditions (collectively, "Standard Terms"); Purchasers of this part are entitled to the rights and benefits contained therein. For a full statement of the Standard Terms and the exclusive rights and remedies thereunder, please visit Mini-Circuits' website at [www.minicircuits.com/MCLStore/terms.jsp](http://www.minicircuits.com/MCLStore/terms.jsp)



# Ceramic Bandpass Filter

50Ω 460 to 776 MHz

## BFTC-618+



Generic photo used for illustration purposes only  
CASE STYLE: FR933-1

### Features

- Good VSWR 1.5 typ. @ passband
- Small size
- Hermetically sealed
- Temperature stable
- LTCC construction

### Applications

- Test and measurement
- Harmonic rejection
- Transmitters / Receivers

### Electrical Specifications<sup>1,2</sup> at 25°C

Parameter	F#	Frequency (MHz)	Min.	Typ.	Max.	Unit
Pass Band	Center Frequency	—	—	618	—	MHz
	Insertion Loss	F1-F2	460-776	—	4.8	dB
	VSWR	F1-F2	460-776	—	1.3	:1
Stop Band, Lower	Insertion Loss	F3-F4	1-330	25	35	dB
	VSWR	F3-F4	1-330	—	16	:1
Stop Band, Upper	Insertion Loss	F5-F6	980-2400	25	30	dB
	VSWR	F5-F6	980-2400	—	10	:1

1. Measured on Mini-Circuits Characterization Test Board TB-233

2. This filter is not intended for use as a DC Blocking circuit element. In Application where DC voltage is present at either input or output ports, blocking capacitors are required at the corresponding RF port.

### Maximum Ratings

Operating Temperature	-40°C to 85°C
Storage Temperature	-55°C to 100°C
RF Power Input*	3 W max @ +25°C

\*Passband rating, derate linearly to 1.5 W at 85°C ambient

Permanent damage may occur if any of these limits are exceeded.

### Functional Schematic

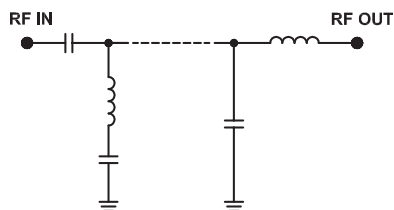

### Typical Frequency Response

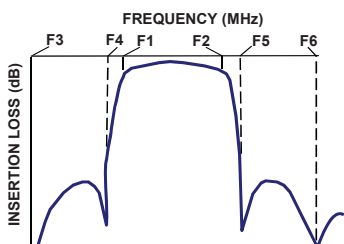

### Typical Performance Data at 25°C

Frequency (MHz)	Insertion Loss (dB)	VSWR (:1)	Frequency (MHz)	Group Delay (nsec)
1	80.59	8168.80	460	5.88
10	60.35	4270.56	468	5.46
100	41.68	101.99	470	5.38
290	46.00	13.65	480	4.90
330	40.52	10.57	490	4.47
340	35.92	9.90	500	4.12
350	31.96	9.26	510	3.88
380	21.77	7.32	550	3.25
450	4.36	1.81	570	3.08
460	3.52	1.43	580	3.00
618	2.03	1.21	600	2.89
776	3.33	1.12	618	2.83
800	4.16	1.34	620	2.85
875	13.10	3.87	650	2.79
910	20.31	5.33	680	2.83
950	29.80	6.86	700	2.88
980	38.66	8.06	720	3.00
1500	34.46	35.78	740	3.16
2000	51.21	47.51	760	3.40
2400	32.85	51.96	776	3.66

### +RoHS Compliant

The +Suffix identifies RoHS Compliance. See our web site for RoHS Compliance methodologies and qualifications

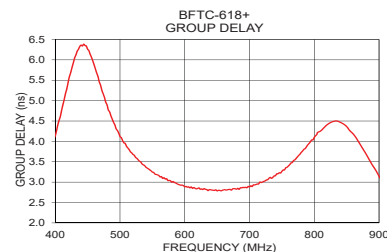
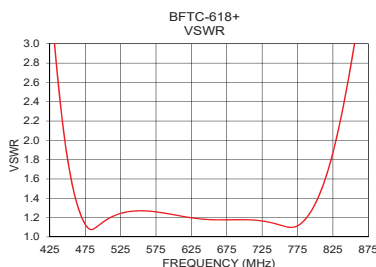
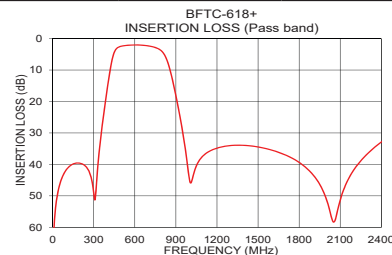
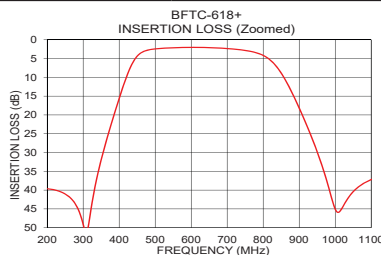

### Notes

- Performance and quality attributes and conditions not expressly stated in this specification document are intended to be excluded and do not form a part of this specification document.
- Electrical specifications and performance data contained in this specification document are based on Mini-Circuit's applicable established test performance criteria and measurement instructions.
- The parts covered by this specification document are subject to Mini-Circuits standard limited warranty and terms and conditions (collectively, "Standard Terms"); Purchasers of this part are entitled to the rights and benefits contained therein. For a full statement of the Standard Terms and the exclusive rights and remedies thereunder, please visit Mini-Circuits' website at [www.minicircuits.com/MCLStore/terms.jsp](http://www.minicircuits.com/MCLStore/terms.jsp)



## Pad Connections

RF IN	2
RF OUT	5
GROUND	1,3,4,6

## Product Marking: 351

Demo Board MCL P/N: TB-233  
Suggested PCB Layout (PL-112)

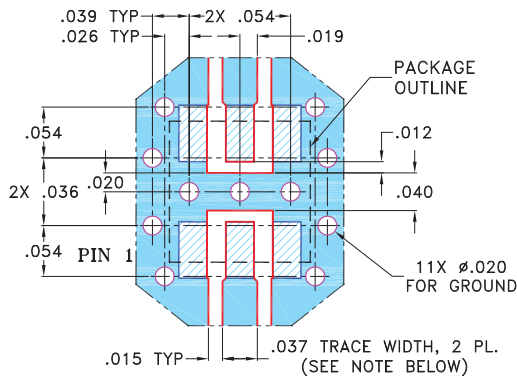

NOTES: 1. TRACE WIDTH IS SHOWN FOR ROGERS R04350B WITH DIELECTRIC THICKNESS 0.020" ± 0.0015"; COPPER: 1/2 OZ. EACH SIDE. FOR OTHER MATERIALS TRACE WIDTH MAY NEED TO BE MODIFIED.

2. BOTTOM SIDE OF THE PCB IS CONTINUOUS GROUND PLANE.

- DENOTES PCB COPPER LAYOUT WITH SMOBC (SOLDER MASK OVER BARE COPPER)
- DENOTES COPPER LAND PATTERN FREE OF SOLDER MASK

## Outline Drawing

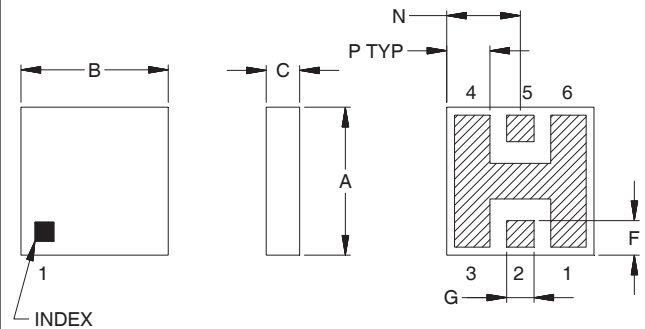

## PCB Land Pattern

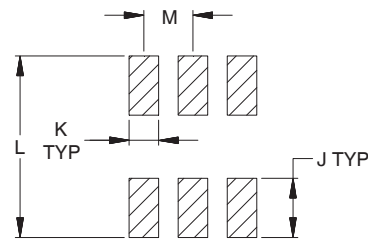

Suggested Layout,  
Tolerance to be within ±.002

## Outline Dimensions (inch/mm)

A	B	C	D	E	F	G	H
.150	.150	.059	--	--	.035	.028	--
3.81	3.81	1.50	--	--	.89	.71	--
J	K	L	M	N	P	Wt.	
.060	.030	.184	.050	.075	.044	grams	
1.52	.76	4.67	1.27	1.91	1.12	0.15	

Note: Please refer to case style drawing for details

### Notes

- A. Performance and quality attributes and conditions not expressly stated in this specification document are intended to be excluded and do not form a part of this specification document.
- B. Electrical specifications and performance data contained in this specification document are based on Mini-Circuit's applicable established test performance criteria and measurement instructions.
- C. The parts covered by this specification document are subject to Mini-Circuit's standard limited warranty and terms and conditions (collectively, "Standard Terms"); Purchasers of this part are entitled to the rights and benefits contained therein. For a full statement of the Standard Terms and the exclusive rights and remedies thereunder, please visit Mini-Circuit's website at [www.minicircuits.com/MCLStore/terms.jsp](http://www.minicircuits.com/MCLStore/terms.jsp)

# Ceramic Band Pass Filter

# BFTC-618+

## Typical Performance Data

FREQ.	Insertion Loss	Input Return Loss	Output Return Loss	FREQ.	Group Delay
(MHz)	(dB)	(dB)	(dB)	(MHz)	(ns)
1	80.59	0.00	0.00	460	5.88
50	46.67	0.01	0.04	462	5.78
75	43.58	0.03	0.09	464	5.68
100	41.68	0.05	0.17	468	5.46
125	40.54	0.08	0.27	474	5.17
150	39.86	0.11	0.39	480	4.90
175	39.57	0.16	0.51	486	4.63
200	39.62	0.22	0.66	492	4.41
225	40.06	0.30	0.81	498	4.20
250	41.05	0.39	0.98	504	4.02
300	49.10	0.63	1.36	510	3.88
320	46.22	0.77	1.54	516	3.75
330	40.52	0.85	1.65	522	3.66
340	35.92	0.94	1.76	528	3.55
360	28.36	1.17	2.02	534	3.45
380	21.77	1.51	2.39	540	3.37
400	15.60	2.14	3.02	546	3.30
420	9.97	3.57	4.41	552	3.24
440	5.70	7.07	7.83	558	3.18
460	3.52	14.14	14.99	564	3.14
480	2.73	23.38	27.76	570	3.08
500	2.43	22.13	22.98	576	3.04
520	2.27	20.68	19.67	582	3.02
540	2.16	20.75	18.62	588	2.96
560	2.09	21.53	18.51	594	2.92
580	2.04	22.69	18.96	600	2.89
600	2.02	23.91	19.76	606	2.89
618	2.03	24.62	20.60	612	2.85
640	2.06	24.48	21.46	618	2.83
660	2.12	23.76	21.78	624	2.83
680	2.21	22.97	21.77	630	2.84
700	2.34	22.49	21.74	636	2.79
720	2.50	22.52	22.11	642	2.81
740	2.71	23.17	23.45	648	2.81
760	2.99	23.97	26.12	654	2.80
776	3.33	22.31	25.05	660	2.81
800	4.16	15.80	16.68	666	2.81
825	5.85	9.86	10.36	672	2.80
850	8.85	6.05	6.59	678	2.84
875	13.10	3.96	4.60	684	2.82
880	14.06	3.69	4.34	690	2.87
900	18.15	2.87	3.57	696	2.86
910	20.31	2.58	3.30	702	2.91
950	29.80	1.85	2.55	708	2.93
980	38.66	1.53	2.17	714	2.95
1000	45.05	1.37	1.95	720	3.00
1100	37.21	0.90	1.22	726	3.05
1200	34.83	0.70	0.85	732	3.12
1300	34.00	0.61	0.65	738	3.15
1400	33.95	0.57	0.55	744	3.21
1500	34.46	0.57	0.49	750	3.27
1600	35.46	0.56	0.44	752	3.30
1700	37.01	0.58	0.41	754	3.30
1800	39.34	0.60	0.40	756	3.35
1900	43.25	0.61	0.38	758	3.37
2000	51.21	0.64	0.37	760	3.40
2100	51.36	0.68	0.35	762	3.43
2200	41.68	0.72	0.35	764	3.47
2300	36.58	0.77	0.34	770	3.55
2400	32.85	0.85	0.33	776	3.66



Typical Performance Curves

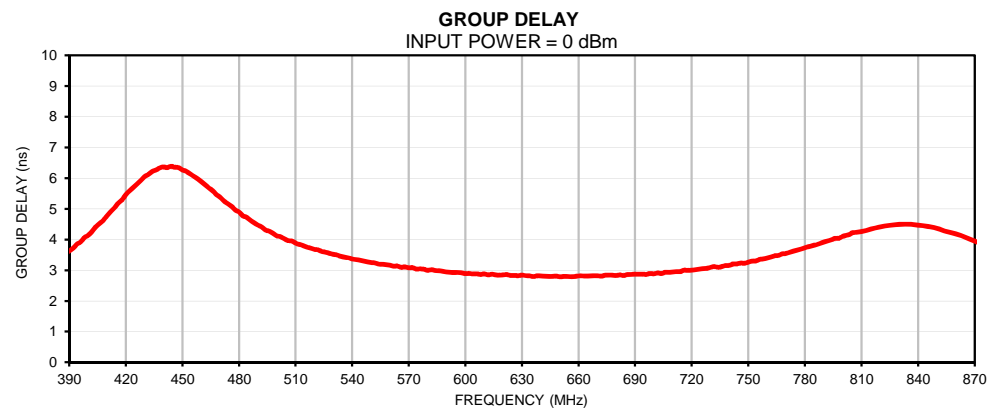
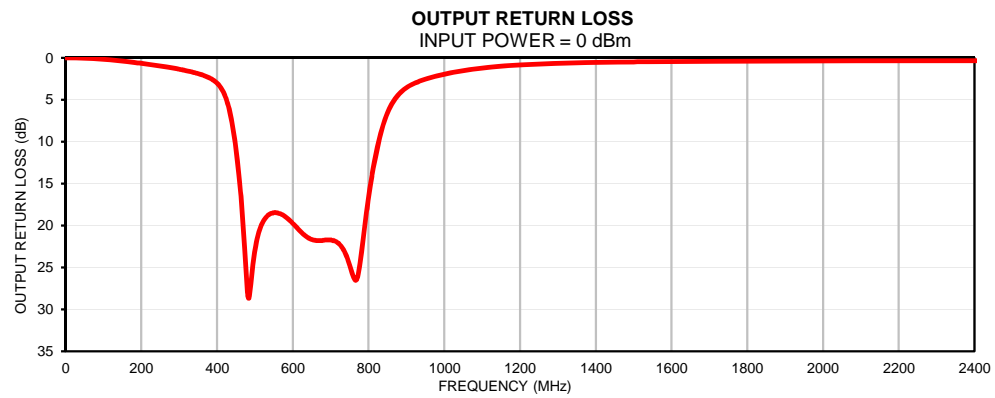
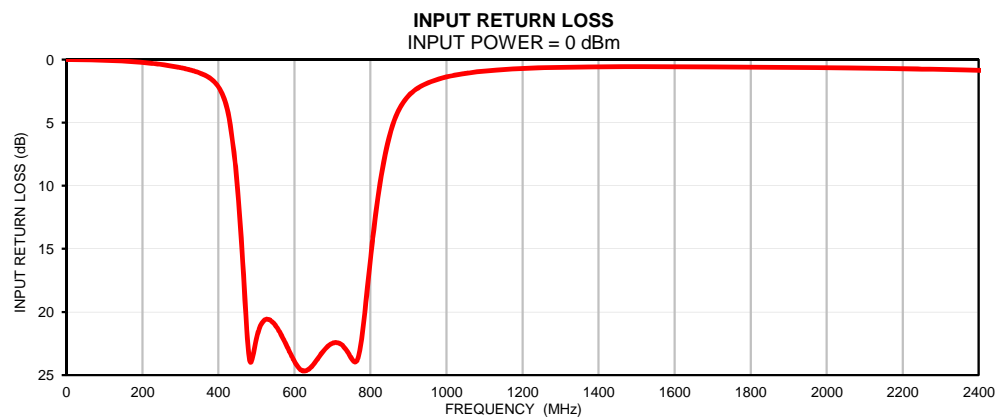
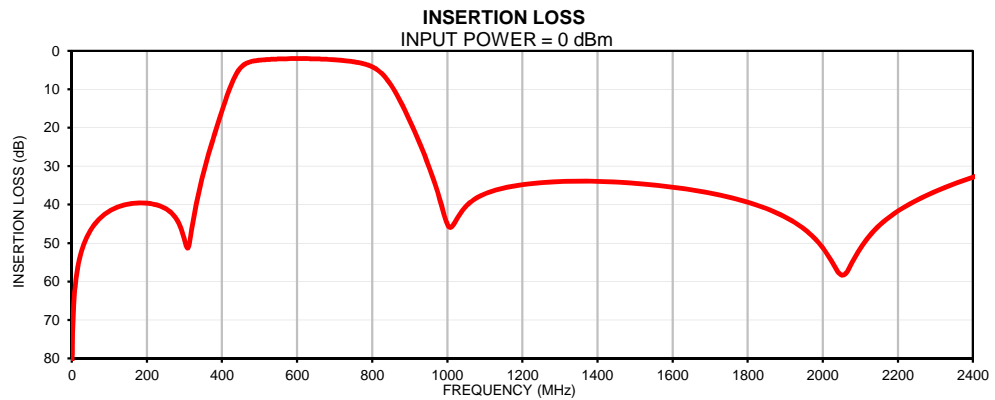

### Outline Dimensions

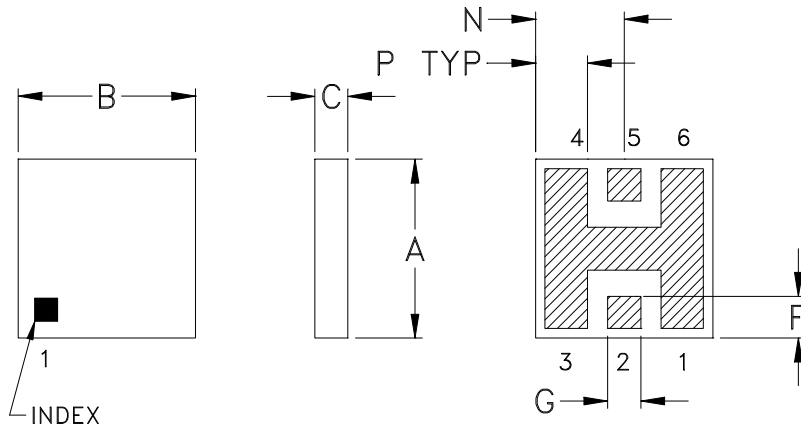

### PCB Land Pattern

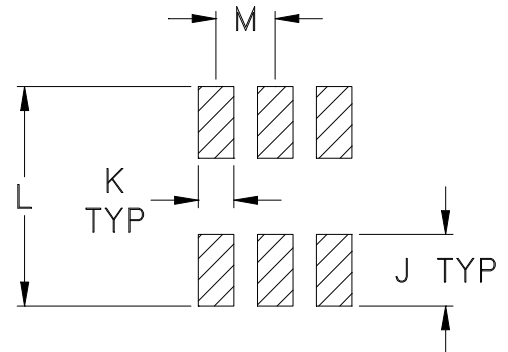

Suggested Layout,  
Tolerance to be within  $\pm .002$

CASE #	A	B	C	D	E	F	G	H	J	K	L	M
FR933-1	.150 (3.81)	.150 (3.81)	.059 (1.50)	-- --	-- --	.035 (0.89)	.028 (0.71)	-- --	.060 (1.52)	.030 (0.76)	.184 (4.67)	.050 (1.27)

CASE #	N	P	WT. GRAM
FR933-1	.075 (1.91)	.044 (1.12)	0.15

Dimensions are in inches (mm). Tolerances: 2Pl.  $\pm .01$ ; 3 Pl.  $\pm .005$

#### Notes:

1. Open style, Ceramic Base.
2. Termination finish: Palladium Silver.

# Tape & Reel Packaging TR-F68

## DEVICE ORIENTATION IN T&R

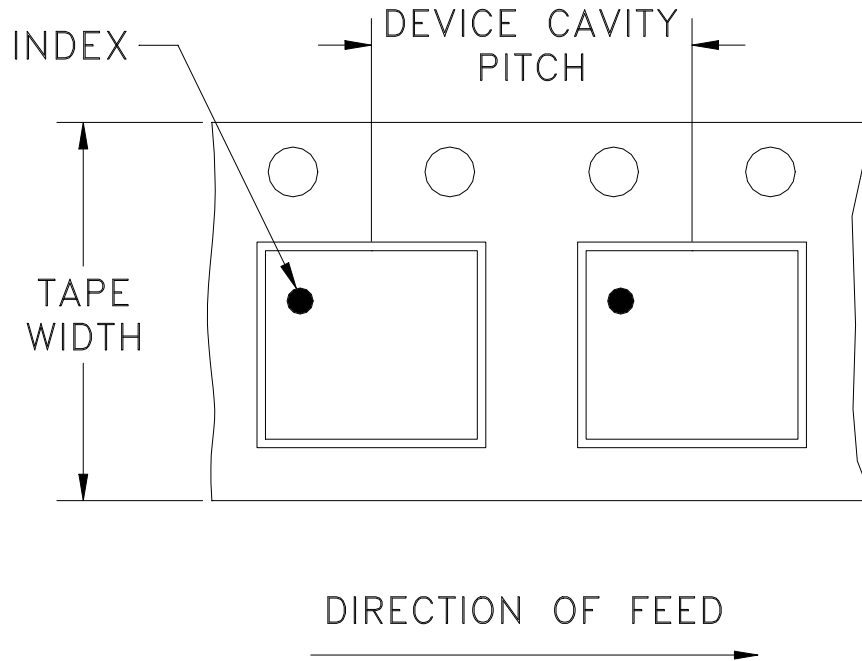

Tape Width, mm	Device Cavity Pitch, mm	Reel Size, inches	Devices per Reel see note	
12	8	7	Small quantity standard	20
				50
				100
				200
				500
		7	Standard	1000
		13	Standard	2000
				3000
				4000

Mini-Circuits carrier tape materials provide protection from ESD (Electro-Static Discharge) during handling and transportation. Tapes are static dissipative and comply with industry standards EIA-481/EIA-541.

Go to: [www.minicircuits.com/pages/pdfs/tape.pdf](http://www.minicircuits.com/pages/pdfs/tape.pdf)



INTERNET <http://www.minicircuits.com>

P.O. Box 350166, Brooklyn, New York 11235-0003 (718) 934-4500 Fax (718) 332-4661

Distribution Centers NORTH AMERICA 800-654-7949 • 417-335-5935 • Fax 417-335-5945 • EUROPE 44-1252-832600 • Fax 44-1252-837010

Mini-Circuits ISO 9001 & ISO 14001 Certified

THIRD ANGLE PROJECTION

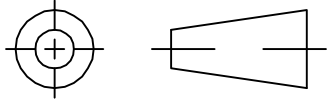

REVISIONS

REV	ECN No.	DESCRIPTION	DATE	DR	AUTH
OR	M83007	NEW RELEASE	09/04/02	MMG	LER
A	M83501	CNG LAYOUT AS PER B14-TB-233	10/01/02	MMG	ABD
B	M102713	ADDED "...WITH SMOBC"	01/14/06	GF	IL
C	M164713	ADDED "933-1 & 06FL03"	11/15/17	CA	IL

**SUGGESTED MOUNTING CONFIGURATION  
FOR FR932/933/933-1 CASE STYLE, "06FL03" PIN CONNECTION**

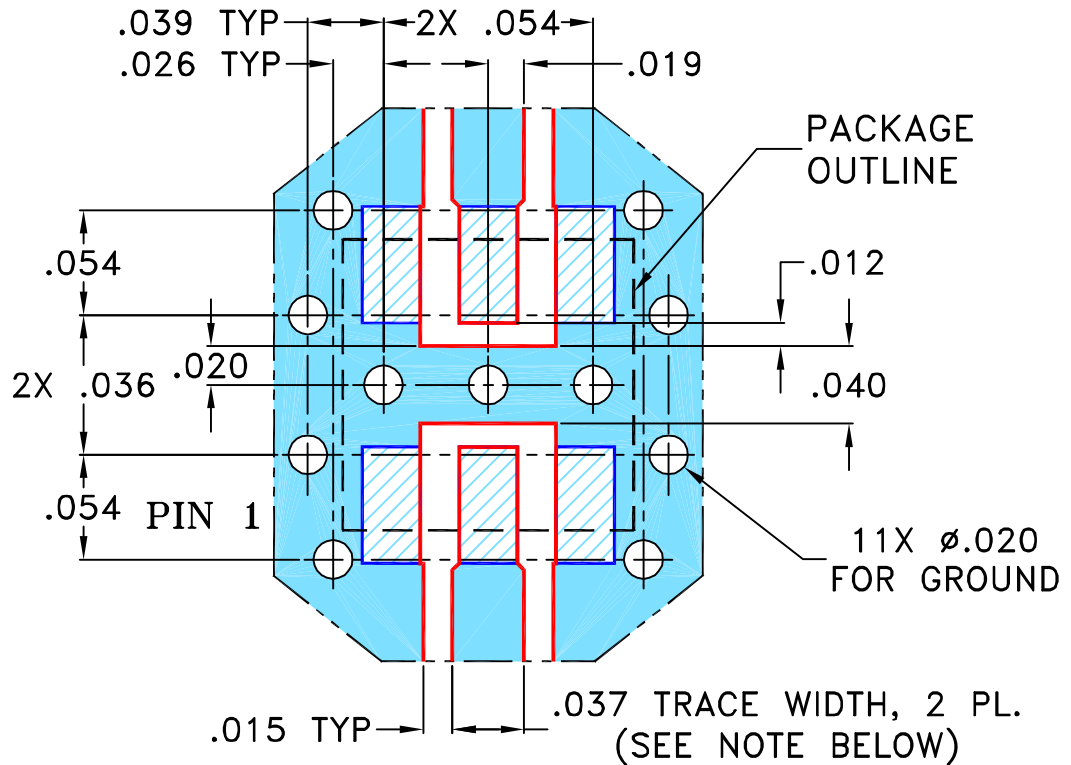

NOTES: 1. TRACE WIDTH IS SHOWN FOR ROGERS R04350B WITH DIELECTRIC THICKNESS 0.020" ± 0.0015"; COPPER: 1/2 OZ. EACH SIDE. FOR OTHER MATERIALS TRACE WIDTH MAY NEED TO BE MODIFIED.

2. BOTTOM SIDE OF THE PCB IS CONTINUOUS GROUND PLANE.



DENOTES PCB COPPER LAYOUT WITH SMOBC (SOLDER MASK OVER BARE COPPER)



DENOTES COPPER LAND PATTERN FREE OF SOLDER MASK

UNLESS OTHERWISE SPECIFIED	INITIALS		DATE
DIMENSIONS ARE IN INCHES TOLERANCES ON: 2 PL DECIMALS ± 3 PL DECIMALS ± ANGLES ± FRACTIONS ±	DRAWN	MMG	09/04/02
	CHECKED		
	APPROVED	LER(BC)	09/04/02



Mini-Circuits®

13 Neptune Avenue  
Brooklyn NY 11235

PL, 06FL03, FR932/933/933-1, TB-233

THIS DOCUMENT AND ITS CONTENTS ARE THE PROPERTY OF MINI-CIRCUITS. EXCEPT FOR USE EXPRESSLY GRANTED, IN WRITING, TO ITS VENDORS, VENDEE AND THE UNITED STATES GOVERNMENT, MINI-CIRCUITS RESERVES ALL PROPRIETARY DESIGN, USE, MANUFACTURING AND REPRODUCTION RIGHTS THERETO. THESE CONTENTS SHALL NOT BE USED, DUPLICATED OR DISCLOSED TO ANY OUTSIDE PARTY, IN WHOLE OR IN PART, WITHOUT WRITTEN PERMISSION OF MINI-CIRCUITS.

SIZE	CODE IDENT	DRAWING NO:	REV:
A	15542	98-PL-112	C
FILE:	98PL112	SCALE:	10:1
		SHEET:	1 OF 1



# Evaluation Board and Circuit

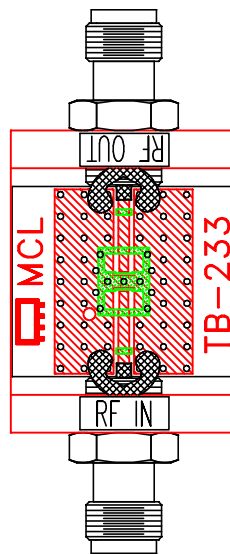

TB-233

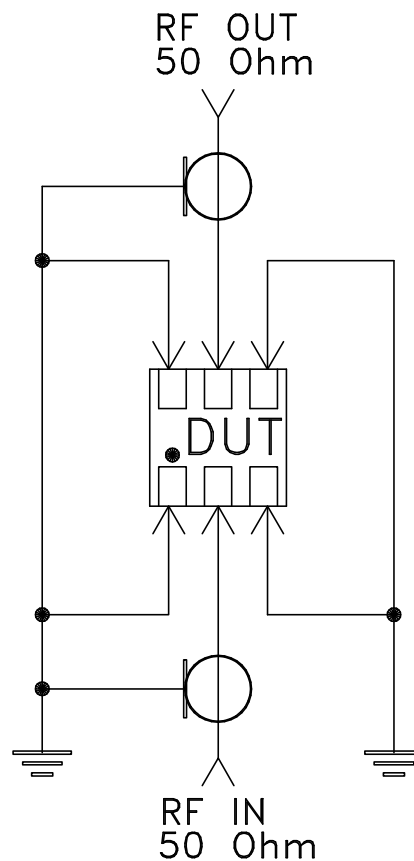

Schematic Diagram

## Notes:

1. SMA Female connectors.
2. PCB Material: Rogers R04350 or equivalent,  
Dielectric Constant=3.5, Thickness=.020 inch.

 **Mini-Circuits®**



All Mini-Circuits products are manufactured under exacting quality assurance and control standards, and are capable of meeting published specifications after being subjected to any or all of the following physical and environmental test.

Specification	Test/Inspection Condition	Reference/Spec
Operating Temperature	-40° to 85°C Ambient Environment	Individual Model Data Sheet
Storage Temperature	-55° to 100° C Ambient Environment	Individual Model Data Sheet
Humidity	90 to 95% RH, 240 hours, 50°C	MIL-STD-202, Method 103, Condition A, Except 50°C and end-point electrical test done within 12 hours
Thermal Shock	-55° to 100°C, 100 cycles	MIL-STD-202, Method 107, Condition A-3, except +100°C
Solder Reflow Heat	Sn-Pb Eutetic Process: 225°C peak Pb-Free Process 245° - 250°C peak	J-STD-020, Table 4-1, 4-2 and 5-2, Figure 5-1
Solderability	10X Magnification	J-STD-002, 95% Coverage
Vibration (High Frequency)	20g peak, 10-2000 Hz, 12 times in each of three perpendicular directions (total 36)	MIL-STD-202, Method 204, Condition D
Mechanical Shock	50g, 11 ms, 1/2-sine, 18 shocks: 3 each direction, each of 3 axes	MIL-STD-202, Method 213, Condition A
Marking Resistance to Solvents	Isopropyl alcohol + mineral spirits at 25°C; terpene defluxer at 25°C; distilled water + proylene glycol monomethyl ether + monoethanolamine at 63°C to 70°C	MIL-STD-202, Method 215