



LTCC SURFACE MOUNT

Bandpass Filter

BFHKI-1272+

50Ω 11.9 to 12.8 GHz

THE BIG DEAL

- LTCC Band Pass Filter with Integrated Interposer Board
- Wide Stopband Rejection, Typ. 30dB up to 38GHz
- Shielded Construction
- Protected by US Patents 11,638,370 and 11,744,057



Generic photo used for illustration purposes only

APPLICATIONS

- Test & Measurement Equipment
- Radar
- SATCOM
- Point-to-Point Radios

FUNCTIONAL DIAGRAM

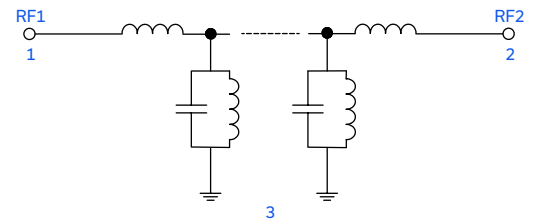

PRODUCT OVERVIEW

BFHKI-1272+ is a miniature low temperature co-fired ceramic (LTCC) ultra-high stopband rejection band pass filter with a 11.9 to 12.8GHz passband, that supports a variety of applications. This model achieves 30dB typical stopband rejection up to 38GHz, when mounted on coplanar waveguide layouts. Housed in a small 4.95mm by 3.65mm ceramic form factor, the filter is ideal for dense signal chain PCB layouts, where it complements MMIC size and performance. The BFHKI family with integrated interposer board enables installation onto PCB layouts with automated manufacturing equipment. This model provides 3.5dB typical insertion loss over a wide band due to its rugged monolithic construction. The LTCC fabrication process assures minimal RF performance variation, while delivering a product that is well suited for environmental extremes of high humidity and temperature.

KEY FEATURES

Features	Advantages
Surface mountable due to Integrated Interposer Board	Enables installation with automated manufacturing equipment, making this suitable for high-volume processes.
Wide Rejection	Provides high stopband rejection of 30dB typical up to 38GHz.
Small Size (4.95 x 3.65mm)	Allows for high layout density of circuit boards, while minimizing effects of parasitics.
Wide Operating and Storage Temperature (-55 to 125°C)	Enables use in high reliability and extreme environment conditions, such as in aerospace & defense applications.
Cost Effective	LTCC is a scalable technology that is cost effective due to ease of production in high-volume

REV. OR
ECO-018846
BFHKI-1272+
MCL NY
231020





LTCC SURFACE MOUNT

Bandpass Filter

BFHKI-1272+

50Ω 11.9 to 12.8 GHz

ELECTRICAL SPECIFICATIONS^{1,2,3} AT +25°C

Parameter	F#	Frequency (GHz)	Min.	Typ.	Max.	Units
Passband	Center Frequency ⁴	—	—	12.35	—	GHz
	Insertion Loss	F2-F3	11.9 - 12.8	3.5	5	dB
	Return Loss	F2-F3	11.9 - 12.8	—	10	dB
Stop Band, Lower	Rejection	DC-F1	0.1 - 8.6	55	65	dB
Stop Band, Upper	Rejection	F4-F5	16.7 - 35	30	35	dB
			35 - 38	25	30	dB

1. Tested on Evaluation Board P/N TB-BFHKI-1272C+. Measured with the connector and feedline effects de-embedded using the 2XThru IEEE P370 method.

2. Bi-directional RF1 and RF2 ports can be interchanged.

3. This component should not be used as a DC-block. In applications where DC voltage and/or current is present at either the input or output ports, external DC blocking capacitors are required.

4. Typical variation ±5%

ABSOLUTE MAXIMUM RATINGS⁵

Parameter	Ratings
Operating Temperature	-55°C to +125°C
Storage Temperature	-55°C to +125°C
Input Power ⁶	1W

5. Permanent damage may occur if any of these limits are exceeded.

6. Power rating applies only to signals within the passband. Power rating above +25°C operating temperature decreases linearly to 0.5W at +125°C.

TYPICAL FREQUENCY RESPONSE AT +25°C

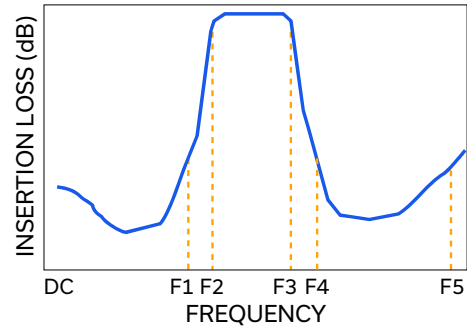



LTCC SURFACE MOUNT

Bandpass Filter

BFHKI-1272+

Mini-Circuits

50Ω 11.9 to 12.8 GHz

TYPICAL PERFORMANCE GRAPHS AT +25°C

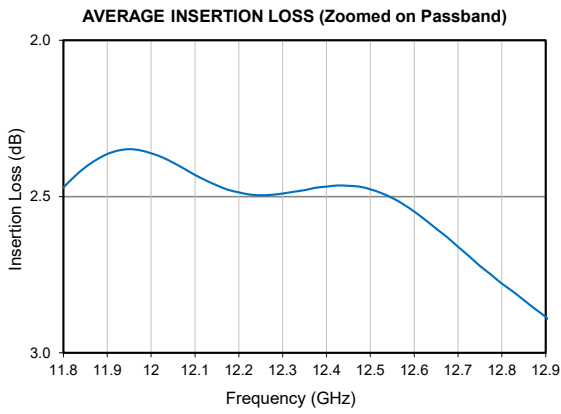
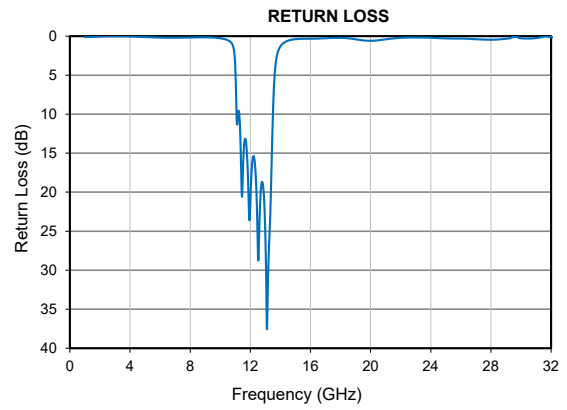
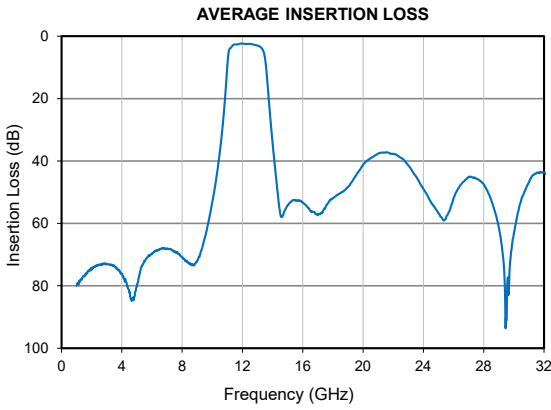



FUNCTIONAL DIAGRAM

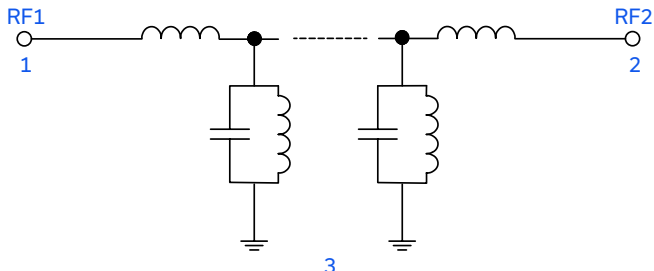
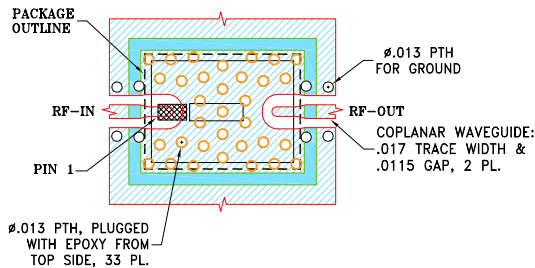

Figure 1. BFHKI-1272+ Functional Diagram

PAD DESCRIPTION

Function	Pad Number	Description
RF1 ²	1	Connects to RF Input Port
RF2 ²	2	Connects to RF Output Port
GROUND	3	Connects to Ground on PCB, (See drawing PL-753)

SUGGESTED PCB LAYOUT (PL-753)



NOTES:

- TRACE WIDTH & GAP PARAMETERS ARE SHOWN FOR ROGERS R04350B WITH DIELECTRIC THICKNESS .010"; COPPER: 1/2 OZ. FOR OTHER MATERIALS TRACE WIDTH AND GAP MAY NEED TO BE MODIFIED.
- BOTTOM SIDE OF THE PCB ARE CONTINUOUS GROUND PLANE.

- DENOTES PCB COPPER LAYOUT WITH SMOBC (SOLDER MASK OVER BARE COPPER)
- DENOTES COPPER LAND PATTERN FREE OF SOLDER MASK

Figure 2. Suggested PCB Layout BFHKI-1272+

CASE STYLE DRAWING

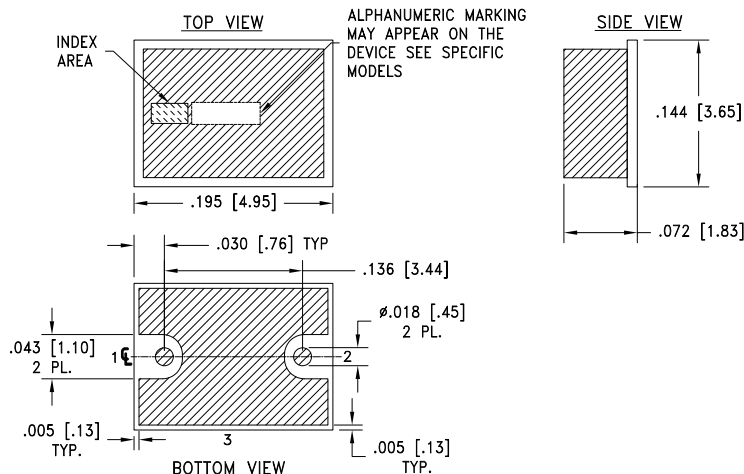

Weight: .135 grams.

Dimensions are in inches [mm]. Tolerances: 2 Pl. ±.01; 3 Pl. ±.005

PRODUCT MARKING*: F443

*Marking may contain other features or characters for internal lot control.



LTCC SURFACE MOUNT

Bandpass Filter

BFHKI-1272+

50Ω 11.9 to 12.8 GHz

ADDITIONAL DETAILED INFORMATION IS AVAILABLE ON OUR DASH BOARD.

[CLICK HERE](#)

Performance Data & Graphs	Data Graphs S-Parameter (S2P Files) Data Set (.zip file) De-embedded to device pads
Case Style	NM3237 Finish: Gold over Nickel Plating
RoHS Status	Compliant
Tape and Reel	TR-F77
Suggested Layout for PCB Design	PL-753
Evaluation Board	TB-BFHKI-1272C+ Gerber File
Environmental Rating	ENV06T12

NOTES

- A. Performance and quality attributes and conditions not expressly stated in this specification document are intended to be excluded and do not form a part of this specification document.
- B. Electrical specifications and performance data contained in this specification document are based on Mini-Circuits' applicable established test performance criteria and measurement instructions.
- C. The parts covered by this specification document are subject to Mini-Circuits' standard limited warranty and terms and conditions (collectively, "Standard Terms"); Purchasers of this part are entitled to the rights and benefits contained therein. For a full statement of the standard terms and the exclusive rights and remedies thereunder, please visit Mini-Circuits' website at www.minicircuits.com/terms/viewterm.html



LTCC Bandpass Filter

BFHKI-1272+

Typical Performance Data		
FREQUENCY (MHz)	INSERTION LOSS (dB)	RETURN LOSS (dB)
100	100.50	0.03
1000	79.99	0.12
2000	74.48	0.05
3000	73.13	0.01
4000	76.30	0.03
5000	79.92	0.11
6000	69.83	0.18
7000	68.15	0.20
8000	70.73	0.17
8600	73.31	0.16
9000	71.99	0.15
10000	53.18	0.27
10500	37.02	0.52
11000	9.19	4.00
11500	2.63	17.78
11900	2.36	21.82
12200	2.49	15.39
12500	2.48	27.29
12800	2.78	18.71
13500	7.28	10.16
14000	34.39	1.31
15000	54.30	0.39
16000	53.32	0.33
16700	56.35	0.29
17000	57.31	0.27
18000	52.00	0.21
19000	48.27	0.40
20000	41.18	0.59
21000	37.65	0.41
22000	37.72	0.22
23000	41.41	0.17
24000	48.98	0.20
25000	56.78	0.28
26000	52.00	0.31
27000	45.11	0.38
28000	47.50	0.46
29000	61.30	0.33
30000	63.15	0.27
31000	46.77	0.25
32000	43.72	0.13
33000	51.14	0.41
34000	56.33	1.09
35000	46.57	0.55
36000	37.89	0.14
38000	51.28	1.75
40000	33.40	0.40



Typical Performance Data

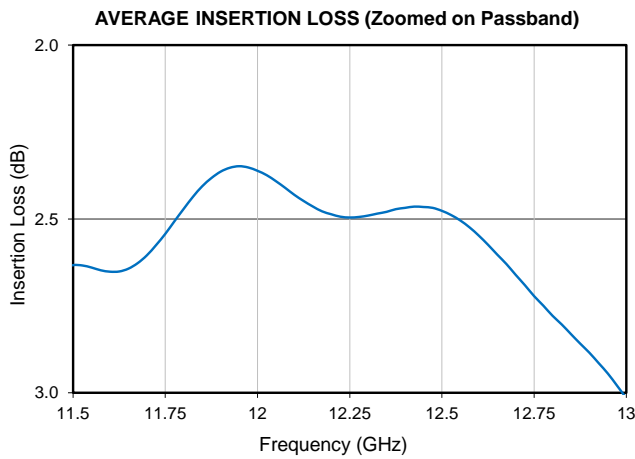
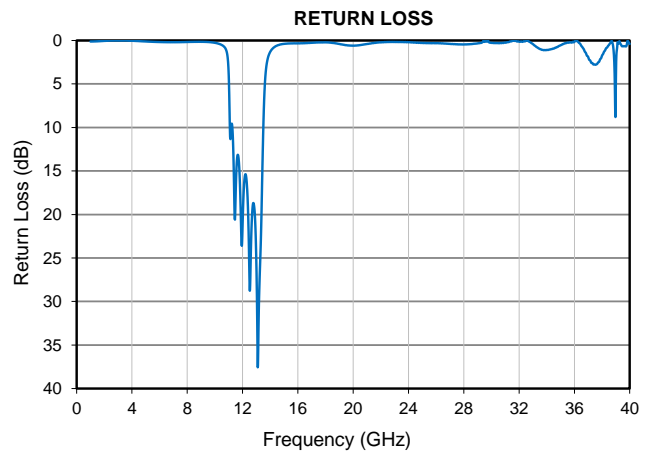
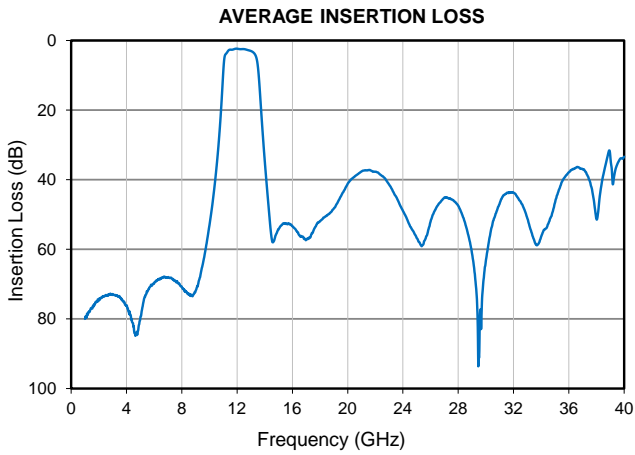

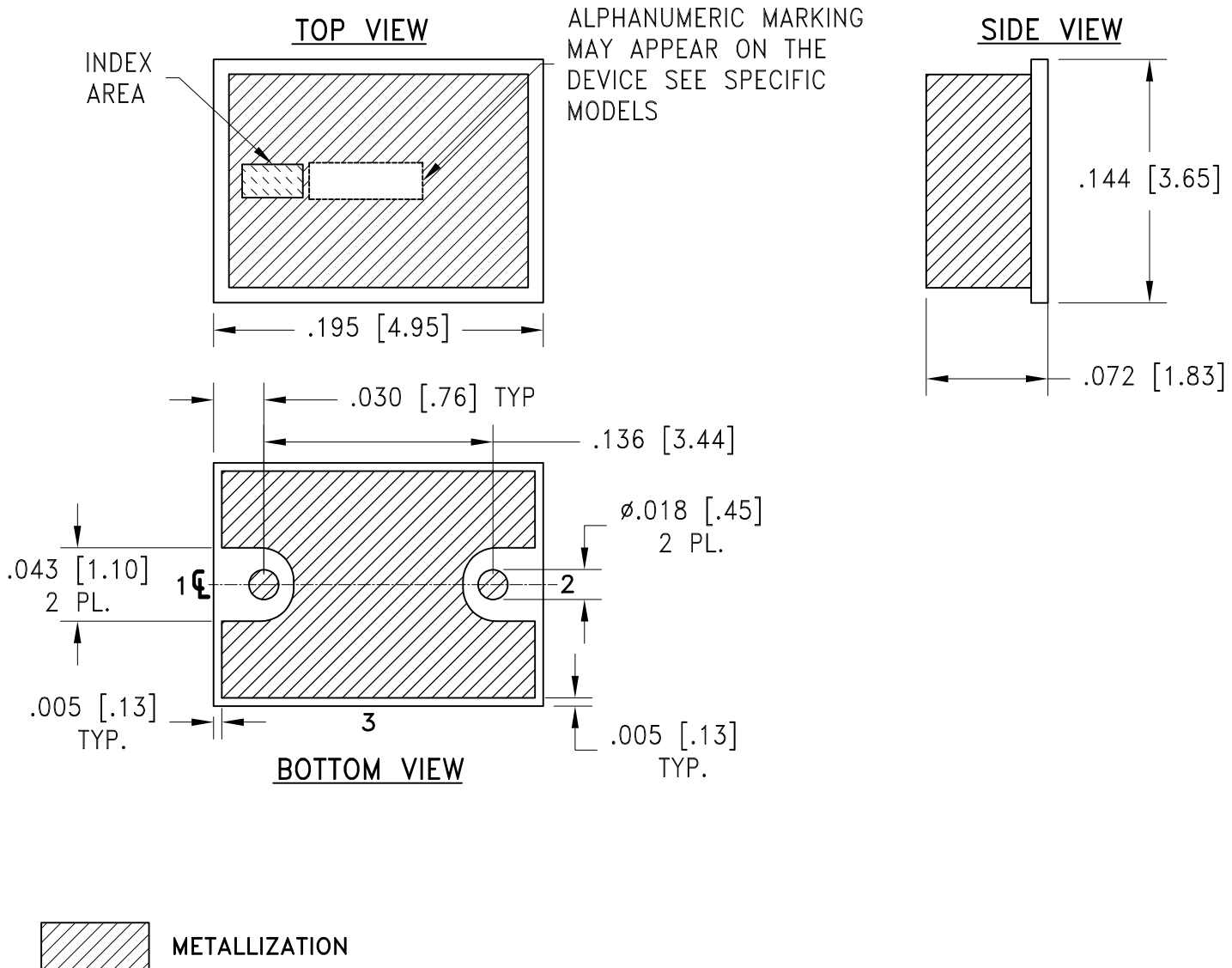

Weight: .135 grams.

Dimensions are in inches (mm). Tolerances: 2 Pl.±.01; 3 Pl. ±.005

Notes:

1. Case material: LTCC on printed circuit board base.
2. Termination Finish: **as shown below or indicated on Data Sheet.**
For RoHS Case Styles: Gold Plate over Nickel plate. All models, (+) suffix.

THIRD ANGLE PROJECTION

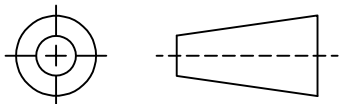

REVISIONS

REV	ECN No.	DESCRIPTION	DATE	DR	AUTH
OR	ECO-017025	NEW RELEASE	03/30/23	ITG	IL
OR1	ECO-018201	CORRECTED TYPO IN NOTE 2	06/16/23	ITG	IL
A	ECO-020890	ADDED DETAIL "A" (SH.2) & DIMENSIONS	02/16/24	ITG	IL

SUGGESTED MOUNTING CONFIGURATION FOR
NM3237 CASE STYLE

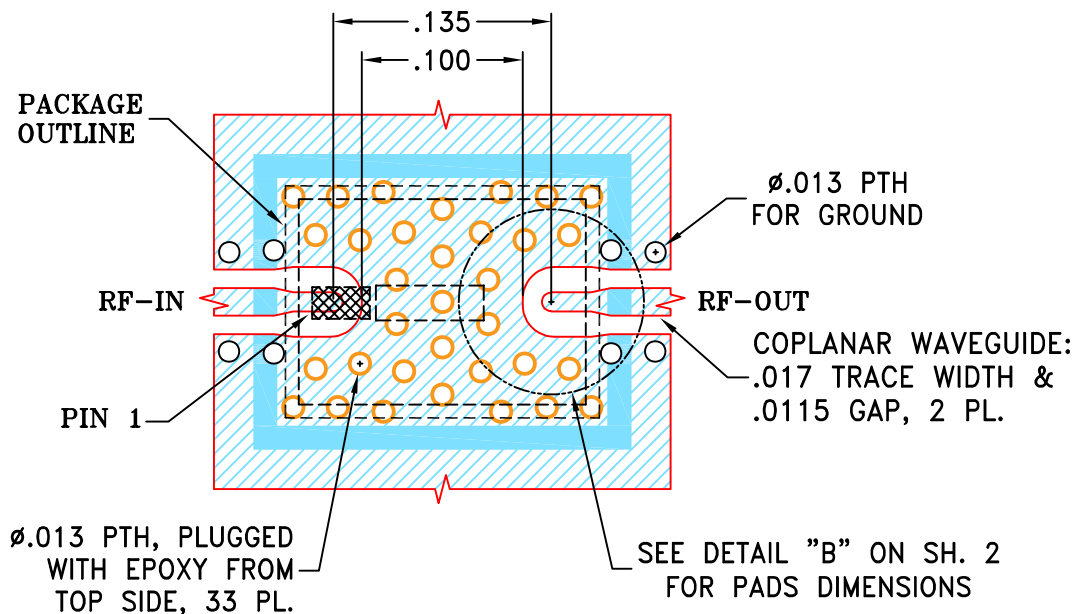

NOTES:

1. TRACE WIDTH & GAP PARAMETERS ARE SHOWN FOR ROGERS R04350B WITH DIELECTRIC THICKNESS .010"; COPPER: 1/2 OZ. FOR OTHER MATERIALS TRACE WIDTH AND GAP MAY NEED TO BE MODIFIED.
2. BOTTOM SIDE OF THE PCB ARE CONTINUOUS GROUND PLANE.



DENOTES PCB COPPER LAYOUT WITH SMOBC (SOLDER MASK OVER BARE COPPER)



DENOTES COPPER LAND PATTERN FREE OF SOLDER MASK

UNLESS OTHERWISE SPECIFIED	INITIALS		DATE
DIMENSIONS ARE IN INCHES	DRAWN	ITG	03/30/23
TOLERANCES ON:	CHECKED	GF	03/30/23
2 PL DECIMALS ±	APPROVED	IL	03/30/23
3 PL DECIMALS ± .005			
ANGLES ±			
FRACTIONS ±			



Mini-Circuits®

13 Neptune Avenue
Brooklyn NY 11235

PL, NM3237, TB-1200

Mini-Circuits®
THIS DOCUMENT AND ITS CONTENTS ARE THE PROPERTY OF MINI-CIRCUITS. EXCEPT FOR USE EXPRESSLY GRANTED, IN WRITING, TO ITS VENDORS, VENDEE AND THE UNITED STATES GOVERNMENT, MINI-CIRCUITS RESERVES ALL PROPRIETARY DESIGN, USE, MANUFACTURING AND REPRODUCTION RIGHTS THERETO. THESE CONTENTS SHALL NOT BE USED, DUPLICATED OR DISCLOSED TO ANY OUTSIDE PARTY, IN WHOLE OR IN PART, WITHOUT WRITTEN PERMISSION OF MINI-CIRCUITS.

SIZE	CODE IDENT	DRAWING NO:	REV:
A	15542	98-PL-753	A
FILE:	98PL753	SCALE: 8:1	SHEET: 1 OF 2

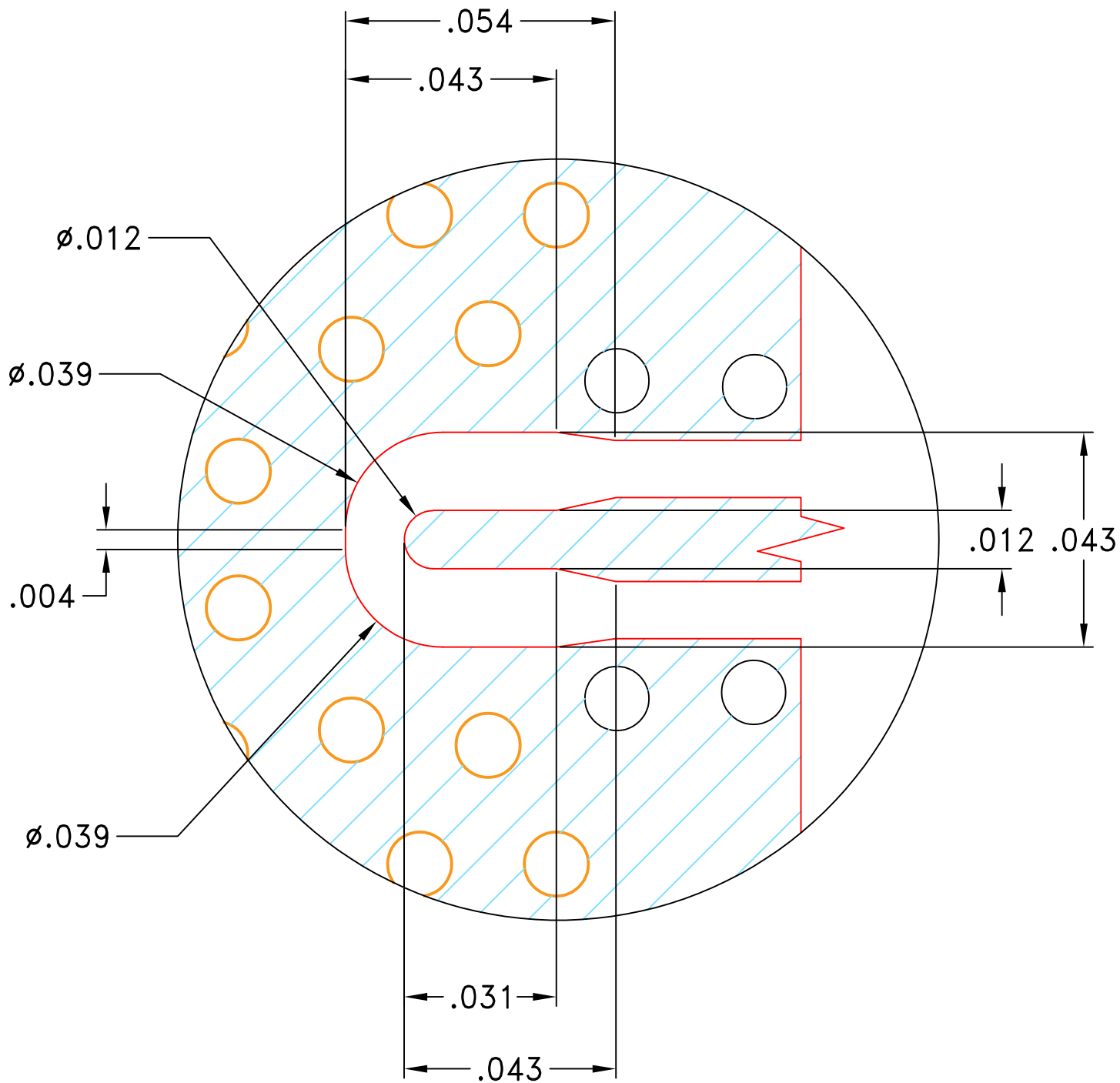

DETAIL "A". SOLDER MASK IS NOT SHOWN FOR CLARITY
 (SCALE 4:1)

 Mini-Circuits

THIS DOCUMENT AND ITS CONTENTS ARE THE PROPERTY OF MINI-CIRCUITS. EXCEPT FOR USE EXPRESSLY GRANTED, IN WRITING, TO ITS VENDORS, VENDEE AND THE UNITED STATES GOVERNMENT, MINI-CIRCUITS RESERVES ALL PROPRIETARY DESIGN, USE, MANUFACTURING AND REPRODUCTION RIGHTS THERETO. THESE CONTENTS SHALL NOT BE USED, DUPLICATED OR DISCLOSED TO ANY OUTSIDE PARTY, IN WHOLE OR IN PART, WITHOUT WRITTEN PERMISSION OF MINI-CIRCUITS.

ALL DIMENSIONS ARE IN INCHES EXCEPT OTHERWISE SPECIFIED

SIZE A	CODE IDENT 15542	DRAWING NO: 98-PL-753	REV: A
FILE: 98PL753	SCALE:	SHEET:	2 OF 2

Evaluation Board and Circuit

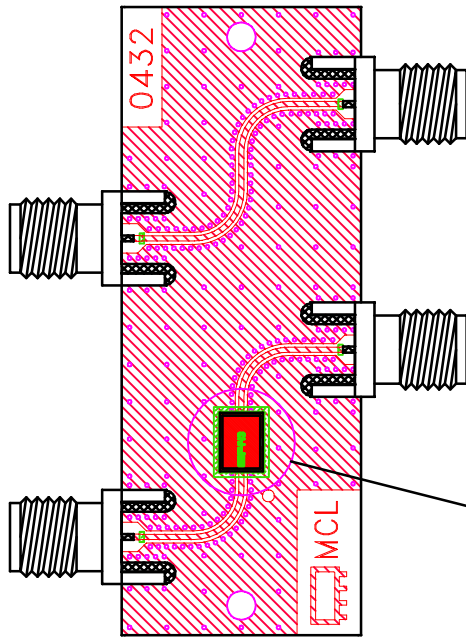

TB-BFHKI-1272C+

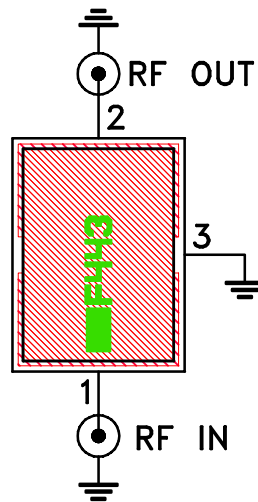
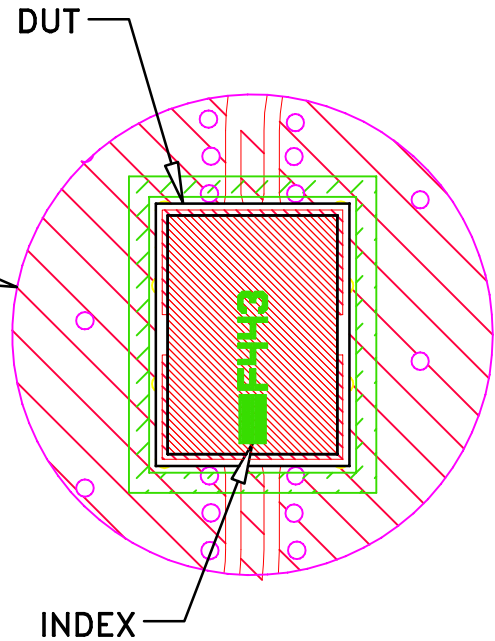

Schematic Diagram

Notes:

1. SMA Female connectors.
2. PCB Material: Rogers R04350 or equivalent, Dielectric Constant=3.5, Thickness=.010 inch.

 Mini-Circuits®

All Mini-Circuits products are manufactured under exacting quality assurance and control standards, and are capable of meeting published specifications after being subjected to any or all of the following physical and environmental test.

Specification	Test/Inspection Condition	Reference/Spec
Operating Temperature	-55° to 125° C Ambient Environment	Individual Model Data Sheet
Storage Temperature	-55° to 125° C Ambient Environment	Individual Model Data Sheet
Thermal Cycling	-55 to 125°C, 100 cycles, Dwell Time 15 minutes.	MIL-STD-202, Method 107, Condition A-3
Humidity	85°C, 90-95% Relative Humidity, 250hours	
Solderability	10X / 30X Magnification	J-STD-002C Test S, J-STD-002C Test S1
High Temp Storage	125°C, 250 hours	
Bend Test	1mm, deflection for 5 seconds Span of bending: 2.75"	--