



CERAMIC

# Bandpass Filter

## BFHK-8501+

Mini-Circuits

50Ω 7.5 to 8.8 GHz

### THE BIG DEAL

- Ultra-High Stopband Rejection Structure – 90 dB typical
- Surface mountable pick and place standard case style
- Standard small 1812 (4.5mm x 3.2mm) case style
- High quality distributed filter topology
- Wide rejection band
- Shielded construction preventing filter from de-tuning
- Reduced footprint area by employing LGA (land grid array)
- Suited for very high-volume production
- Protected by US Patents 11,638,370 and 11,744,057



Generic photo used for illustration purposes only

CASE STYLE: NM1812C-3

### +RoHS Compliant

The +Suffix identifies RoHS Compliance. See our website for methodologies and qualifications

### APPLICATIONS

- Test and Measurement
- Aerospace and Defense Signal Conditioning

### PRODUCT OVERVIEW

The BFHK-8501+ LTCC Band Pass Filter achieves a miniature size and high repeatability of performance by utilizing a proprietary LTCC material system and distributed filter topology. The passband loss at 7.5 – 8.8 GHz is as low as 3.1 dB, with typical stopband rejections at 90 dB up to 25 GHz. This model handles up to 1W RF input power, and provides a wide operating temperature range from -55 to +125°C. Utilizing a proprietary LTCC material system and a distributed filter topology, this filter is able to achieve repeatable performance on a lot-to-lot basis, up to mmWave frequencies.

### KEY FEATURES

Feature	Advantages
Ultra-High Rejection	Typical stopband rejections at 90 dB up to 25 GHz
Cost effective	LTCC is scalable technology that is cost effective due to ease of production in high quantities.
Small size (4.5mm x 3.2mm)	Allows for high layout density of circuit boards, while minimizing effects of parasitics.
Surface Mountable	Suitable for very high volume automated assembly process.

REV. A  
ECO-019695  
BFHK-8501+  
WY/CP/PS  
231102





CERAMIC

# Bandpass Filter

## BFHK-8501+

### ELECTRICAL SPECIFICATIONS<sup>1</sup> AT 25°C

Parameter	F#	Frequency (GHz)	Min.	Typ.	Max.	Units
Center Frequency	—	—	—	8.1	—	GHz
Pass Band	Insertion Loss	F1-F2	—	3.1	4.5	dB
	Return Loss	F1-F2	—	12	—	dB
Stop Band, Lower	Insertion Loss	DC-F3	80	90	—	dB
Stop Band, Upper	Insertion Loss	F4-F5	80	90	—	dB

1. Measured on Mini-Circuits Test Board TB-BFHK-8501C+ with feedline losses removed by normalization of S12 and S21 traces to measurement of TB thru-line.

### MAXIMUM RATINGS

Parameter	Ratings
Operating Temperature	-55°C to 125°C
Storage Temperature	-55°C to 125°C
RF Power Input	1W max.

Permanent damage may occur if any of these limits are exceeded

### TYPICAL FREQUENCY RESPONSE

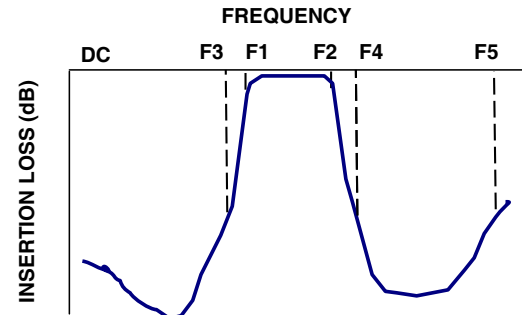

### FUNCTIONAL SCHEMATIC

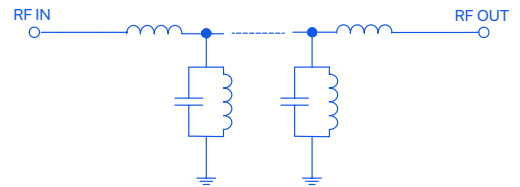



CERAMIC

# Bandpass Filter

# BFHK-8501+

## EVALUATION BOARD MCL P/N: TB-BFHK-8501C+ SUGGESTED PCB LAYOUT: PL-730

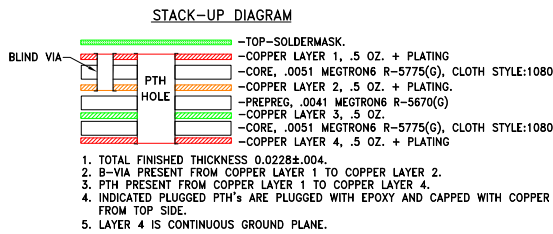
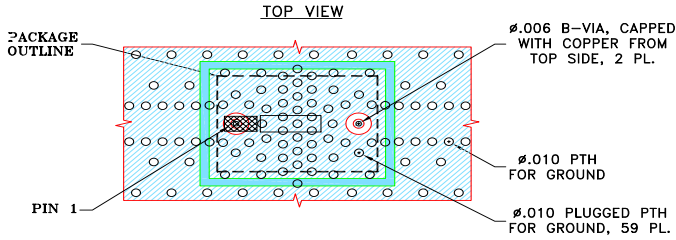

- NOTES:**
- PCB IS MULTILAYER PCB, SEE STACK-UP DIAGRAM.
  - TRACE WIDTH & GAP PARAMETERS ARE SHOWN FOR MEGTRON6 R-5775(G), CLOTH STYLE:1080 WITH DIELECTRIC THICKNESS .0051; COPPER: 1/2 OZ.+PLATING. FOR OTHER MATERIALS TRACE WIDTH AND GAP MAY NEED TO BE MODIFIED.
  - COPPER LAYER 4 OF THE PCB ARE CONTINUOUS GROUND PLANE.

- DENOTES PCB COPPER LAYOUT WITH SMOBC (SOLDER MASK OVER BARE COPPER)
- DENOTES COPPER LAND PATTERN FREE OF SOLDER MASK

### LAYER 2, B-VIA & PTH

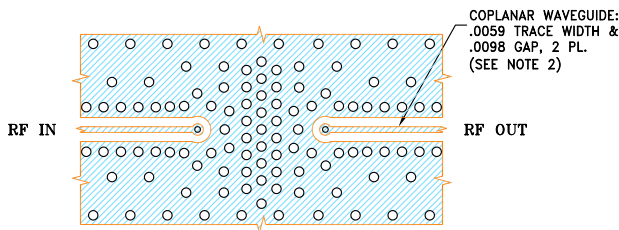

### LAYER 3 & PTH

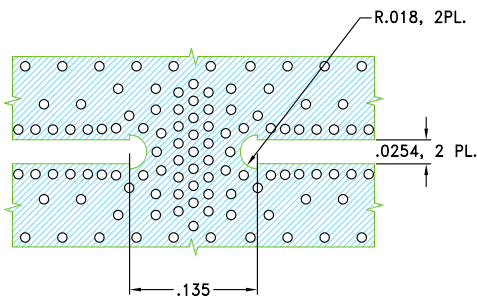

## PAD CONNECTIONS

INPUT	1
OUTPUT	2
GROUND	3

PRODUCT MARKING: F440

## OUTLINE DRAWING

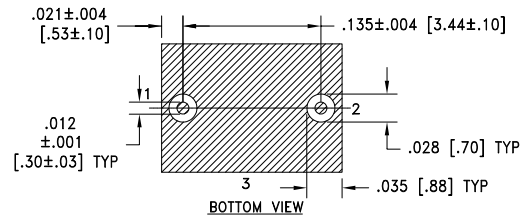
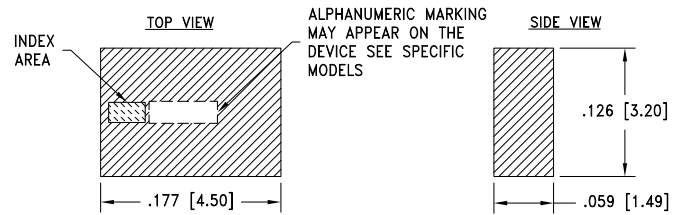

Weight: .126 grams.  
 Dimensions are in inches (mm). Tolerances: 2 Pl.±.01; 3 Pl. ±.005



CERAMIC

# Bandpass Filter

## BFHK-8501+

### TYPICAL PERFORMANCE DATA

Frequency (MHz)	Insertion Loss (dB)	Return Loss (dB)
10	68.13	0.05
2000	110.07	0.43
3000	114.78	0.63
4700	95.94	0.70
6000	66.50	0.76
7500	2.59	15.68
8100	2.32	29.74
8800	2.78	25.90
10500	65.57	1.80
11900	104.42	1.66
13500	105.16	1.15
15000	101.10	1.78
16500	100.74	2.16
18000	117.69	1.83
19500	110.59	1.57
21000	113.71	2.31
23000	108.05	2.34
24000	99.79	2.31
25000	112.14	2.19
27000	93.35	2.65
30000	15.32	4.55

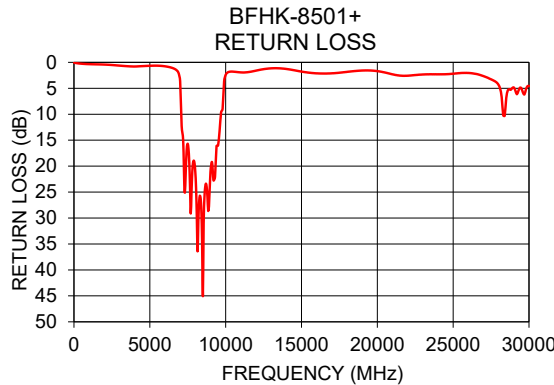
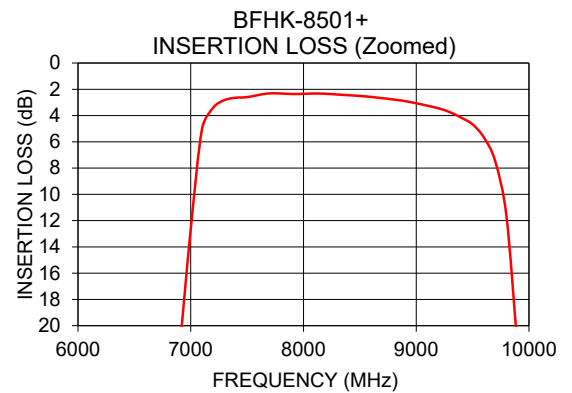
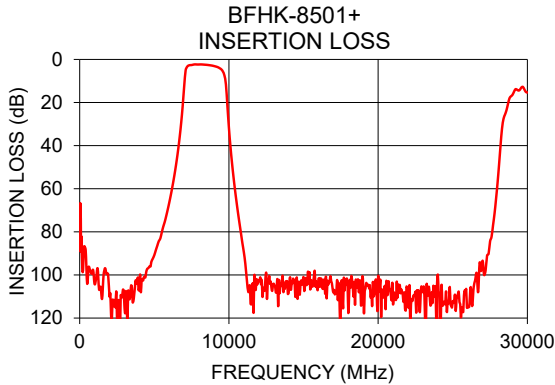

- NOTES**
- A. Performance and quality attributes and conditions not expressly stated in this specification document are intended to be excluded and do not form a part of this specification document.
  - B. Electrical specifications and performance data contained in this specification document are based on Mini-Circuit's applicable established test performance criteria and measurement instructions.
  - C. The parts covered by this specification document are subject to Mini-Circuits standard limited warranty and terms and conditions (collectively, "Standard Terms"); Purchasers of this part are entitled to the rights and benefits contained therein. For a full statement of the standard. Terms and the exclusive rights and remedies thereunder, please visit Mini-Circuits' website at [www.minicircuits.com/MCLStore/terms.jsp](http://www.minicircuits.com/MCLStore/terms.jsp)



# Ceramic Bandpass Filter

# BFHK-8501+

## Typical Performance Data

FREQUENCY (MHz)	INSERTION LOSS (dB)	RETURN LOSS (dB)
10	68.13	0.05
50	73.51	0.08
100	81.90	0.12
500	103.99	0.26
1000	104.26	0.35
1500	111.07	0.39
2000	110.07	0.43
2500	120.09	0.51
3000	114.78	0.63
3500	105.88	0.74
4000	104.98	0.80
4500	97.55	0.73
4700	95.94	0.70
5000	90.81	0.66
5500	80.27	0.64
5900	69.64	0.72
6000	66.50	0.76
7000	12.64	3.60
7500	2.59	15.68
7550	2.52	16.64
7600	2.44	19.14
7650	2.36	23.69
7700	2.31	29.13
7750	2.31	24.98
7800	2.32	21.16
7850	2.34	19.35
7900	2.36	18.93
7950	2.36	19.46
8000	2.35	21.15
8050	2.35	21.15
8100	2.32	29.74
8150	2.33	36.42
8200	2.34	30.66
8250	2.37	27.01
8300	2.40	25.69
8350	2.43	26.17
8400	2.45	28.70
8450	2.48	34.85
8500	2.51	45.07
8550	2.54	31.04
8600	2.58	26.17
8650	2.63	24.08
8700	2.68	23.37
8750	2.73	24.02
8800	2.78	25.90
8850	2.84	28.65
8900	2.90	27.77
8950	2.90	27.77
9000	3.06	21.08
9500	4.67	16.05
10000	31.76	2.42
10500	65.57	1.80
11000	89.44	1.94
11500	113.63	1.87
11900	104.42	1.66
12500	99.17	1.32
13000	104.03	1.16
13500	105.16	1.15
14000	108.31	1.28
14500	104.69	1.51
15000	101.10	1.78
15500	102.34	1.99
16000	101.84	2.12
16500	100.74	2.16
17000	108.17	2.11
17500	115.51	2.00
18000	117.69	1.83
18500	102.37	1.68
19000	105.46	1.58
19500	110.59	1.57
20000	100.37	1.69
21000	113.71	2.31
22000	113.60	2.57
23000	108.05	2.34
24000	99.79	2.31
25000	112.14	2.19
26000	115.03	2.04
27000	93.35	2.65
28000	57.39	4.38
29000	16.46	4.85
30000	15.32	4.55



P.O. Box 350166, Brooklyn, New York 11235-0003 (718) 934-4500 • Fax (718) 332-4661 For detailed performance specs & shopping online see Mini-Circuits web site  
 The Design Engineers Search Engine Provides ACTUAL Data Instantly From MINI-CIRCUITS At: [www.minicircuits.com](http://www.minicircuits.com)



IF/RF MICROWAVE COMPONENTS

REV. OR  
 BFHK-8501+  
 8/10/2021  
 Page 1 of 1

## Typical Performance Curves

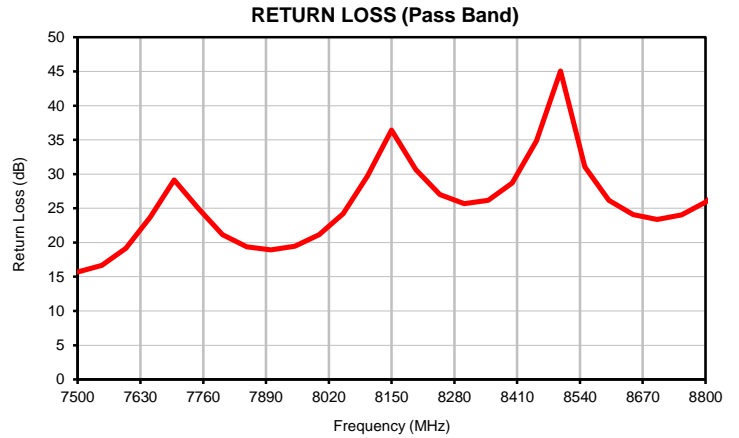
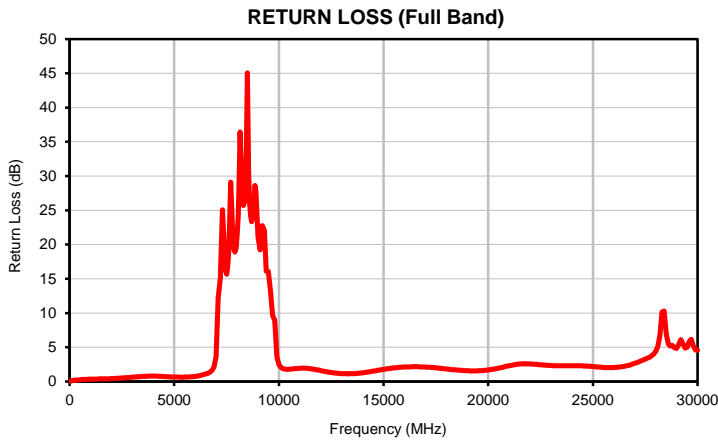
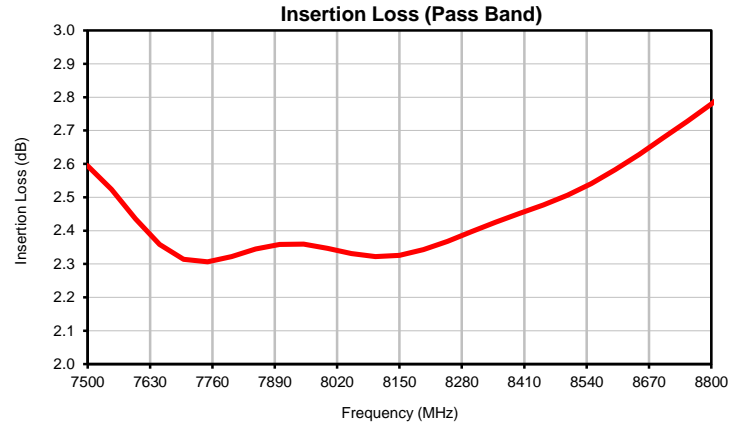
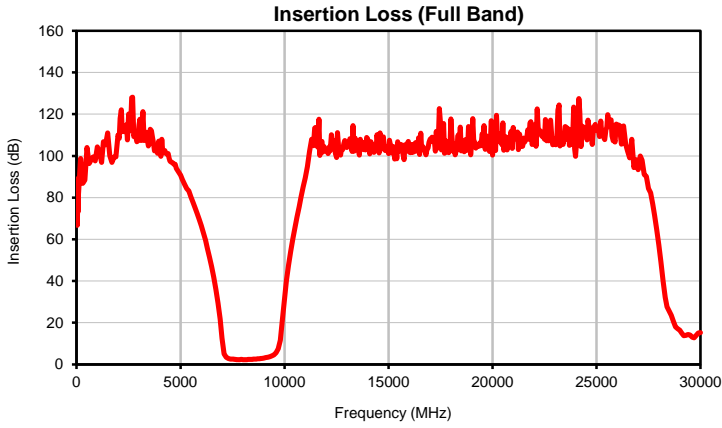

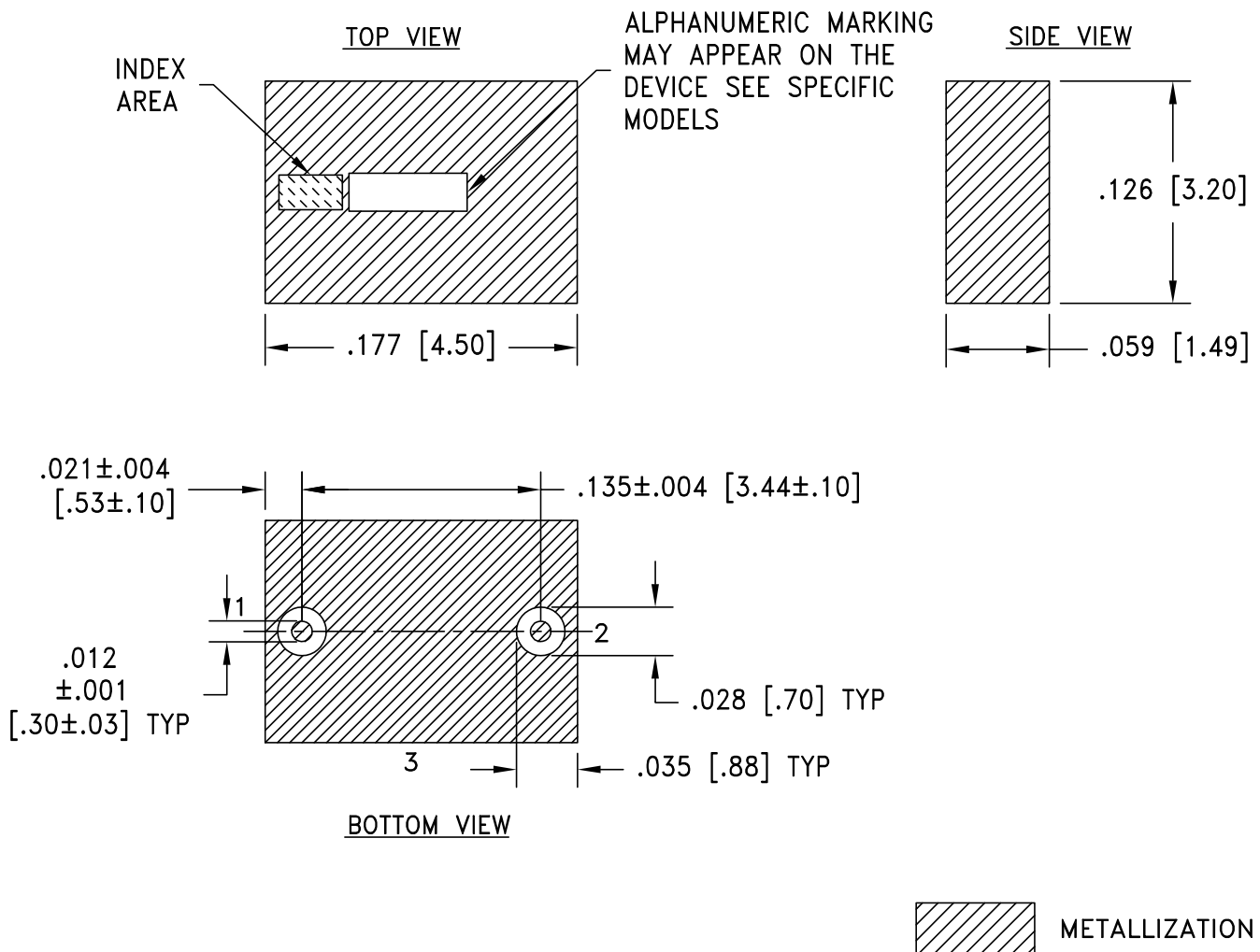

Weight: .126 grams.

Dimensions are in inches [mm]. Tolerances: 2 Pl.  $\pm .01$ ; 3 Pl.  $\pm .005$  Inches

### Notes:

1. Case material: Ceramic.
2. Termination Finish: **as shown below or indicated on Data Sheet.**  
For RoHS Case Styles: Tin Plate over Nickel plate. All models, (+) suffix.

**Mini-Circuits®**  
ISO 9001 ISO 14001 CERTIFIED

ALL NEW  
minicircuits.com

P.O. Box 350166, Brooklyn, New York 11235-0003 (718) 934-4500 Fax (718) 332-4661 For detailed performance specs & shopping online see Mini-Circuits web site



The Design Engineers Search Engine Provides ACTUAL Data Instantly From MINI-CIRCUITS At: [www.minicircuits.com](http://www.minicircuits.com)

RF/IF MICROWAVE COMPONENTS

THIRD ANGLE PROJECTION

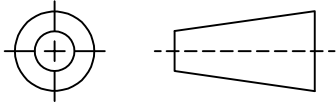

REVISIONS

REV	ECN No.	DESCRIPTION	DATE	DR	AUTH
OR	ECO-013254	NEW RELEASE	05/16/22	ITG	IL
A	ECO-015587	UPDATED STACK-UP DIAGRAM	11/01/22	ITG	IL
B	ECO-020890	ADDED DIMENSIONS	02/16/24	ITG	IL

SUGGESTED MOUNTING CONFIGURATION FOR  
NM1812C-3 CASE STYLE

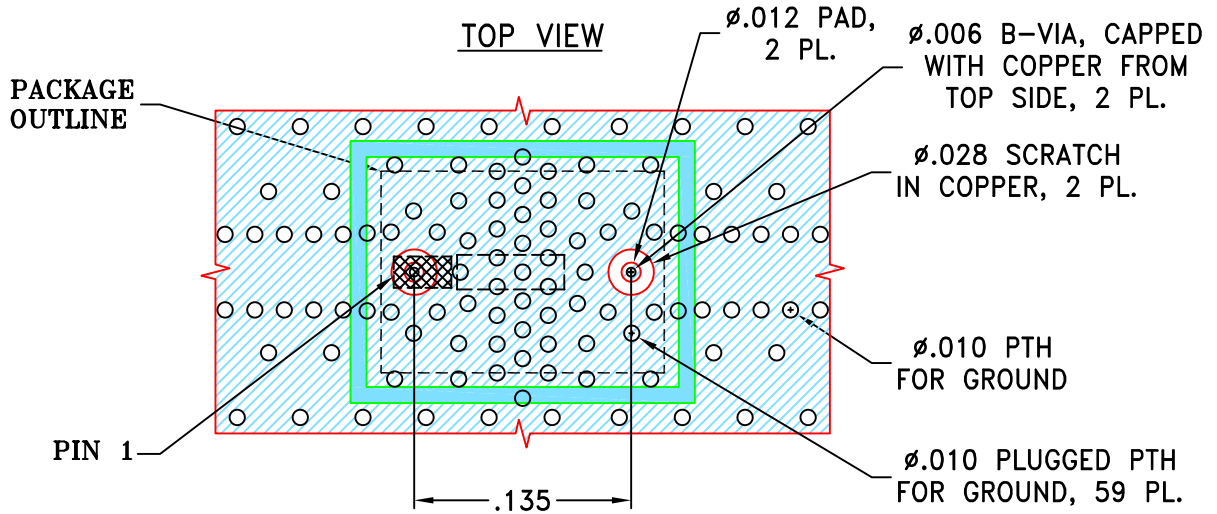

STACK-UP DIAGRAM

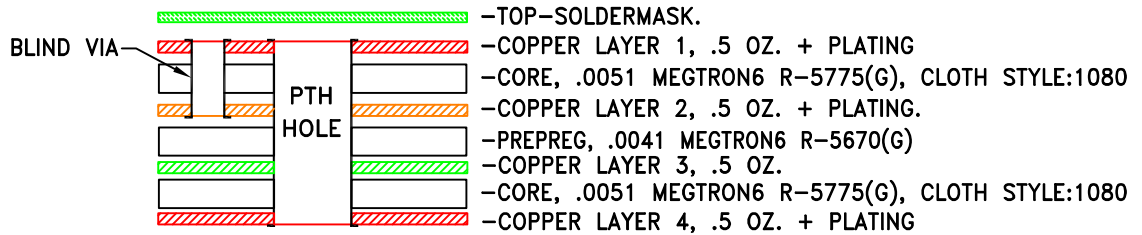

- TOTAL FINISHED THICKNESS 0.0228±.004.
- B-VIA PRESENT FROM COPPER LAYER 1 TO COPPER LAYER 2.
- PTH PRESENT FROM COPPER LAYER 1 TO COPPER LAYER 4.
- INDICATED PLUGGED PTH'S ARE PLUGGED WITH EPOXY AND CAPPED WITH COPPER FROM TOP SIDE.
- LAYER 4 IS CONTINUOUS GROUND PLANE.

NOTES:

- PCB IS MULTILAYER PCB, SEE STACK-UP DIAGRAM.
- TRACE WIDTH & GAP PARAMETERS ARE SHOWN FOR MEGTRON6 R-5775(G), CLOTH STYLE:1080 WITH DIELECTRIC THICKNESS .0051; COPPER: 1/2 OZ.+PLATING. FOR OTHER MATERIALS TRACE WIDTH AND GAP MAY NEED TO BE MODIFIED.
- COPPER LAYER 4 OF THE PCB ARE CONTINUOUS GROUND PLANE.



DENOTES PCB COPPER LAYOUT WITH SMOBC (SOLDER MASK OVER BARE COPPER)

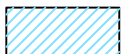

DENOTES COPPER LAND PATTERN FREE OF SOLDER MASK

UNLESS OTHERWISE SPECIFIED	INITIALS		DATE
	DRAWN	ITG	05/16/22
	CHECKED	GF	05/16/22
	APPROVED	IL	05/16/22

DIMENSIONS ARE IN INCHES  
TOLERANCES ON:  
2 PL DECIMALS ±  
3 PL DECIMALS ± .005  
ANGLES ±  
FRACTIONS ±



**Mini-Circuits**<sup>®</sup> 13 Neptune Avenue  
Brooklyn NY 11235

PL, NM1812C-3, TB-1239

Mini-Circuits<sup>®</sup>  
THIS DOCUMENT AND ITS CONTENTS ARE THE PROPERTY OF MINI-CIRCUITS. EXCEPT FOR USE EXPRESSLY GRANTED, IN WRITING, TO ITS VENDORS, VENDEE AND THE UNITED STATES GOVERNMENT, MINI-CIRCUITS RESERVES ALL PROPRIETARY DESIGN, USE, MANUFACTURING AND REPRODUCTION RIGHTS THERETO. THESE CONTENTS SHALL NOT BE USED, DUPLICATED OR DISCLOSED TO ANY OUTSIDE PARTY, IN WHOLE OR IN PART, WITHOUT WRITTEN PERMISSION OF MINI-CIRCUITS.

SIZE	CODE IDENT	DRAWING NO:	REV:
A	15542	98-PL-730	B
FILE:	98PL730	SCALE: 8:1	SHEET: 1 OF 2



LAYER 2, B-VIA & PTH

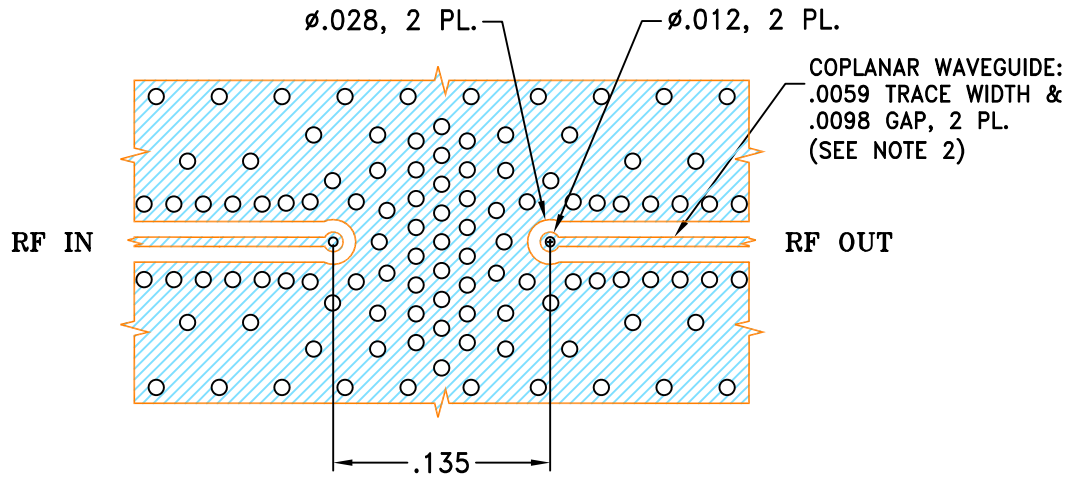

LAYER 3 & PTH

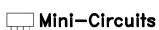
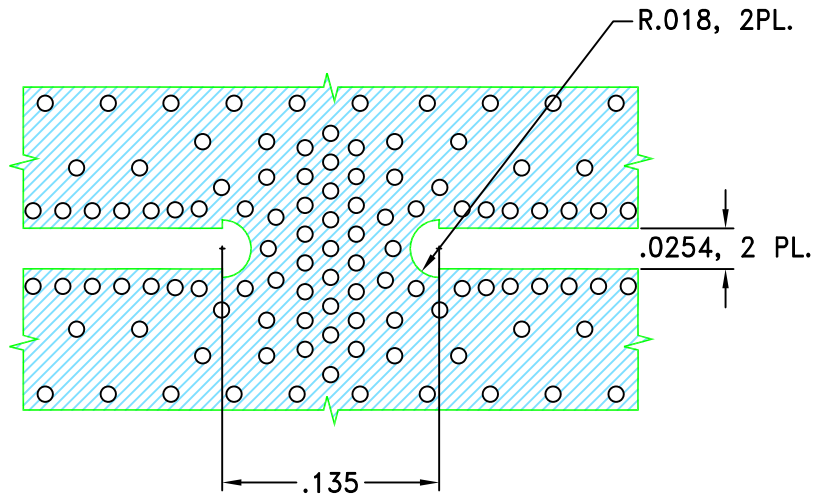

THIS DOCUMENT AND ITS CONTENTS ARE THE PROPERTY OF MINI-CIRCUITS. EXCEPT FOR USE EXPRESSLY GRANTED, IN WRITING, TO ITS VENDORS, VENDEE AND THE UNITED STATES GOVERNMENT, MINI-CIRCUITS RESERVES ALL PROPRIETARY DESIGN, USE, MANUFACTURING AND REPRODUCTION RIGHTS THERETO. THESE CONTENTS SHALL NOT BE USED, DUPLICATED OR DISCLOSED TO ANY OUTSIDE PARTY, IN WHOLE OR IN PART, WITHOUT WRITTEN PERMISSION OF MINI-CIRCUITS.

ALL DIMENSIONS ARE IN INCHES EXCEPT OTHERWISE SPECIFIED

SIZE A	CODE IDENT 15542	DRAWING NO: 98-PL-730	REV: B
FILE: 98PL730	SCALE: 8:1	SHEET: 2 OF 2	

# Evaluation Board and Circuit

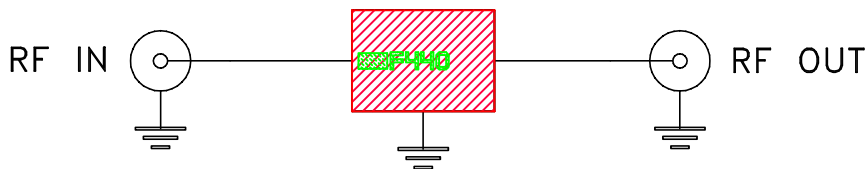
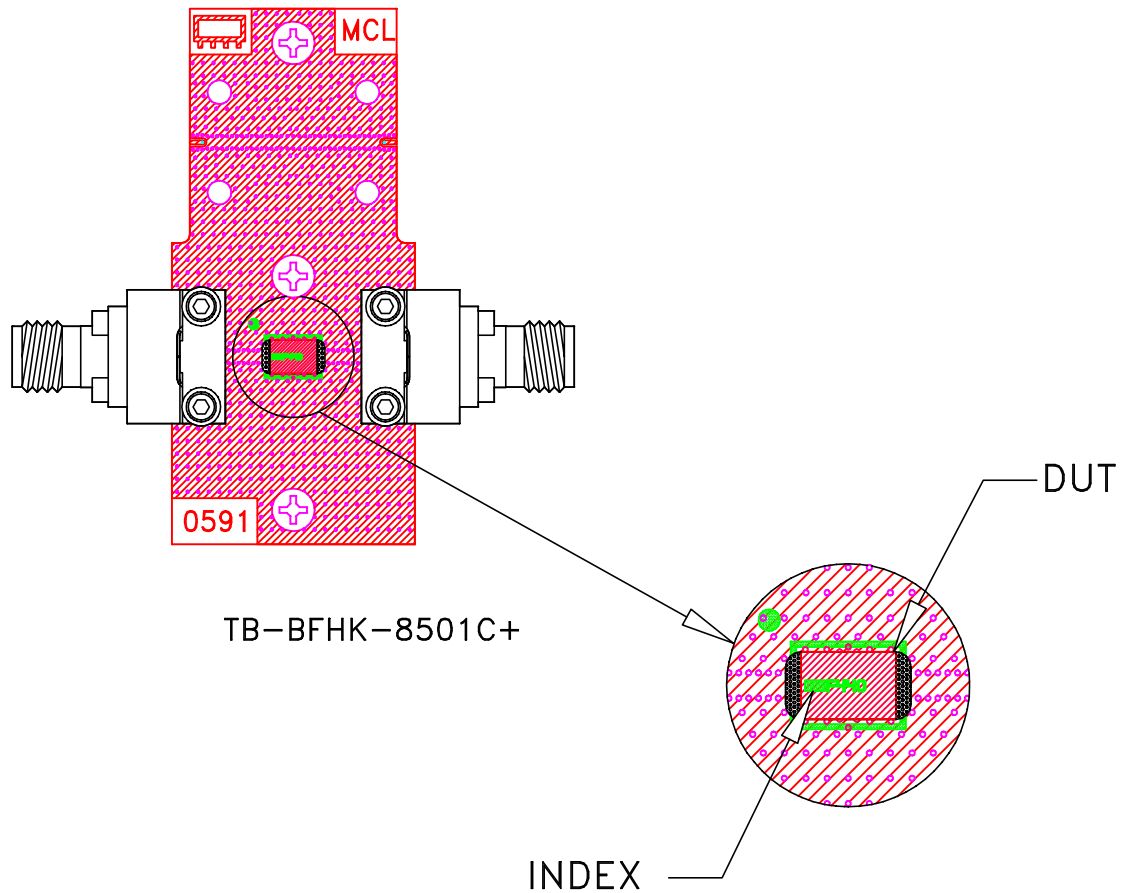

Schematic Diagram

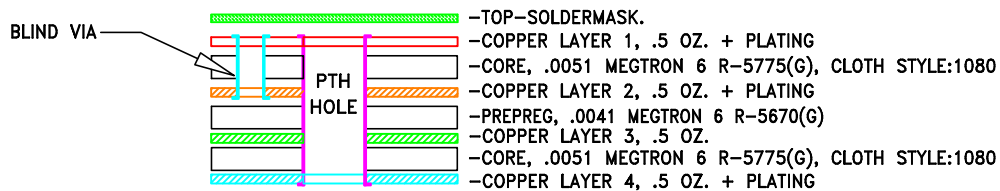

STACK-UP DIAGRAM

## Notes:

1. 2.92 mm Female End Launch Connector.
2. PCB Material: Megtron 6 R5775(N).  
Dielectric Constant=3.6.
3. Total finished thickness .023".

 **Mini-Circuits®**



All Mini-Circuits products are manufactured under exacting quality assurance and control standards, and are capable of meeting published specifications after being subjected to any or all of the following physical and environmental test.

Specification	Test/Inspection Condition	Reference/Spec
Operating Temperature	-55° to 125° C Ambient Environment	Individual Model Data Sheet
Storage Temperature	-55° to 125° C Ambient Environment	Individual Model Data Sheet
Thermal Cycling	-55 to 125°C, 100 cycles, Dwell Time 15 minutes.	MIL-STD-202, Method 107, Condition A-3
Mechanical Shock	50g, 11ms half-sine, 18 shocks applied each to 3 axes	MIL-STD-202 Method 213, Condition A
Vibration	10-2000Hz sine, 20g, 12 cycles applied each to 3 axes	MIL-STD-202, Method 204, Condition D
Constant Acceleration	30Kg, Y1 Direction	MIL-STD-883, Method 2001, Condition E
Humidity	85°C, 90-95% Relative Humidity, 250hours	
Solderability	10X / 30X Magnification	J-STD-002C Test S, J-STD-002C Test S1
High Temp Storage	125°C, 250 hours	