



CERAMIC

Bandpass Filter

BFHK-1072+

50Ω 9.2 to 11.3 GHz

THE BIG DEAL

- Ultra-High Stopband Rejection Structure – 90 dB typical
- Surface mountable pick and place standard case style
- Standard small 1812 (4.5mm x 3.2mm) case style
- High quality distributed filter topology
- Wide rejection band
- Shielded construction preventing filter from de-tuning
- Reduced footprint area by employing LGA (land grid array)
- Suited for very high-volume production
- Protected by US Patents 11,638,370 and 11,744,057



Generic photo used for illustration purposes only

CASE STYLE: NM1812C-3

+RoHS Compliant

The +Suffix identifies RoHS Compliance. See our website for methodologies and qualifications

APPLICATIONS

- Test and Measurement
- Aerospace and Defense Signal Conditioning

PRODUCT OVERVIEW

The BFHK-1072+ LTCC Band Pass Filter achieves a miniature size and high repeatability of performance by utilizing a proprietary LTCC material system and distributed filter topology. The passband loss at 9.2 – 11.3 GHz is as low as 3.1 dB, with typical stopband rejections at 90 dB up to 30 GHz. This model handles up to 1W RF input power, and provides a wide operating temperature range from -55 to +125°C. Utilizing a proprietary LTCC material system and a distributed filter topology, this filter is able to achieve repeatable performance on a lot-to-lot basis, up to mmWave frequencies.

KEY FEATURES

Feature	Advantages
Ultra-High Rejection	Typical stopband rejections at 90 dB up to 30 GHz
Cost effective	LTCC is scalable technology that is cost effective due to ease of production in high quantities.
Small size (4.5mm x 3.2mm)	Allows for high layout density of circuit boards, while minimizing effects of parasitics.
Surface Mountable	Suitable for very high volume automated assembly process.

REV. A
 ECO-019695
 BFHK-1072+
 WY/CP/PS
 231102





CERAMIC

Bandpass Filter

BFHK-1072+

ELECTRICAL SPECIFICATIONS¹ AT 25°C

Parameter	F#	Frequency (GHz)	Min.	Typ.	Max.	Units
Center Frequency	—	—	—	10.2	—	GHz
Pass Band	Insertion Loss	F1-F2	—	3.1	4.5	dB
	Return Loss	F1-F2	—	12.0	—	dB
Stop Band, Lower	Insertion Loss	DC-F3	80	90	—	dB
Stop Band, Upper	Insertion Loss	F4-F5	80	90	—	dB

1. Measured on Mini-Circuits Test Board TB-BFHK-1072C+ with feedline losses removed by normalization of S12 and S21 traces to measurement of TB thru-line.

MAXIMUM RATINGS

Parameter	Ratings
Operating Temperature	-55°C to 125°C
Storage Temperature	-55°C to 125°C
RF Power Input	1W max.

Permanent damage may occur if any of these limits are exceeded

TYPICAL FREQUENCY RESPONSE

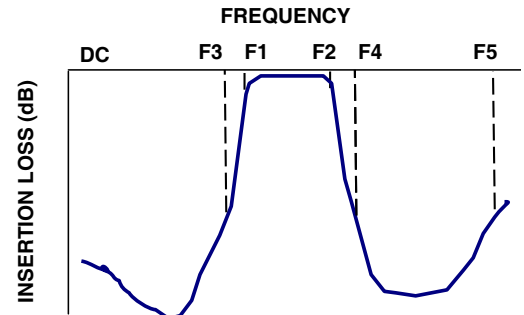

FUNCTIONAL SCHEMATIC

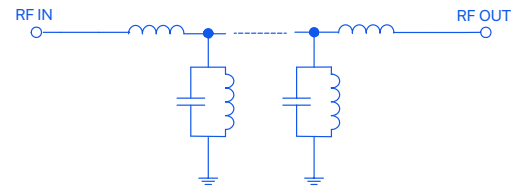



CERAMIC

Bandpass Filter

BFHK-1072+

EVALUATION BOARD MCL P/N: TB-BFHK-1072C+ SUGGESTED PCB LAYOUT: PL-730

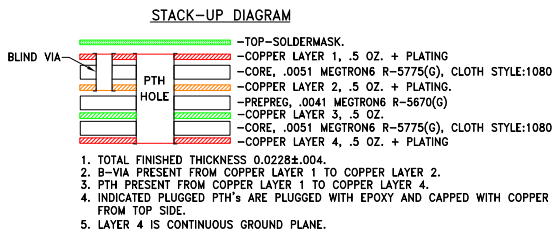
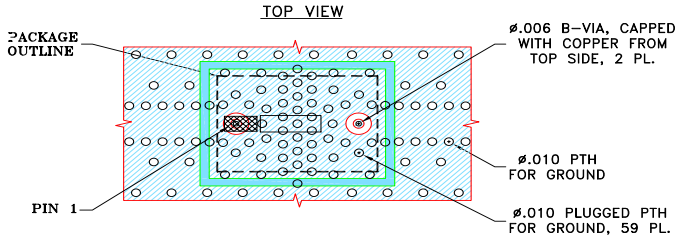

NOTES:

- PCB IS MULTILAYER PCB, SEE STACK-UP DIAGRAM.
- TRACE WIDTH & GAP PARAMETERS ARE SHOWN FOR MEGTRON6 R-5775(G), CLOTH STYLE:1080 WITH DIELECTRIC THICKNESS .0051; COPPER: 1/2 OZ.+PLATING. FOR OTHER MATERIALS TRACE WIDTH AND GAP MAY NEED TO BE MODIFIED.
- COPPER LAYER 4 OF THE PCB ARE CONTINUOUS GROUND PLANE.

- DENOTES PCB COPPER LAYOUT WITH SMOBC (SOLDER MASK OVER BARE COPPER)
- DENOTES COPPER LAND PATTERN FREE OF SOLDER MASK

LAYER 2, B-VIA & PTH

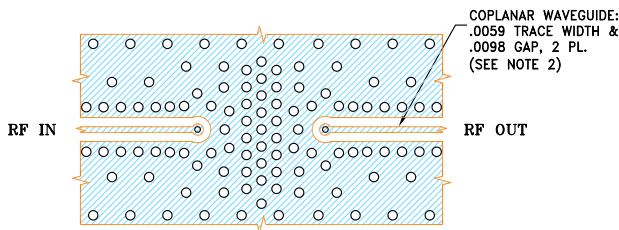

LAYER 3 & PTH

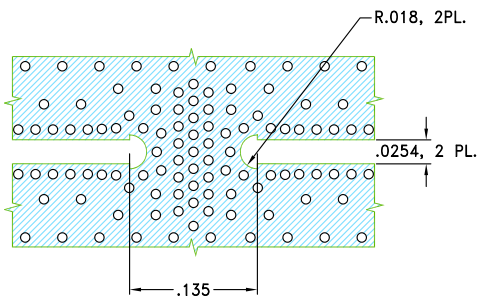

PAD CONNECTIONS

INPUT	1
OUTPUT	2
GROUND	3

PRODUCT MARKING: F442

OUTLINE DRAWING

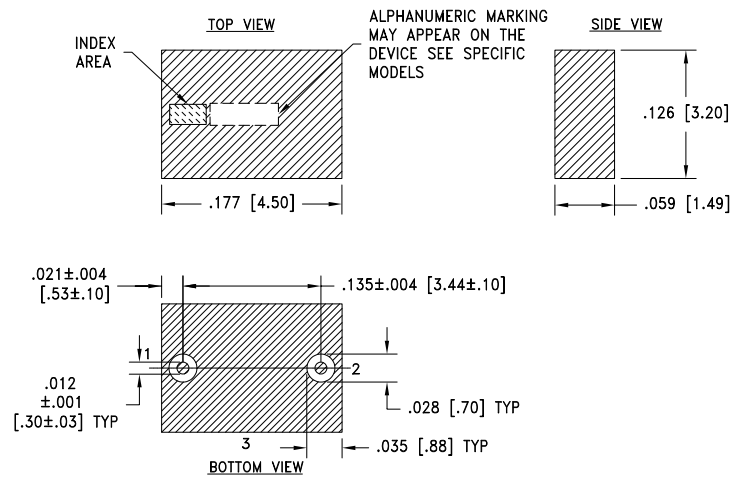

Weight: .126 grams.
Dimensions are in inches (mm). Tolerances: 2 Pl.±.01; 3 Pl. ±.005



CERAMIC

Bandpass Filter

BFHK-1072+

TYPICAL PERFORMANCE DATA

Frequency (MHz)	Insertion Loss (dB)	Return Loss (dB)
10	82.38	0.07
1000	100.34	0.33
2000	113.16	0.31
3000	109.81	0.40
4000	100.31	0.59
6000	85.53	0.68
7500	61.56	0.93
9200	2.20	24.06
10200	1.96	24.23
10800	2.19	25.56
11300	2.53	23.50
12000	3.70	26.62
14000	86.61	1.44
15000	93.34	1.48
18000	97.22	1.73
22000	97.31	1.76
24000	102.43	2.00
26000	96.61	2.00
28000	87.56	2.00
30000	107.52	2.32

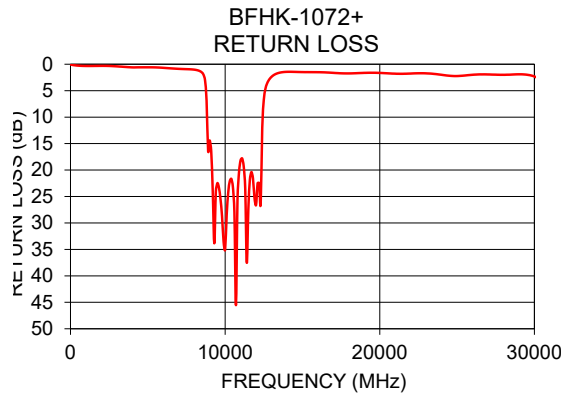
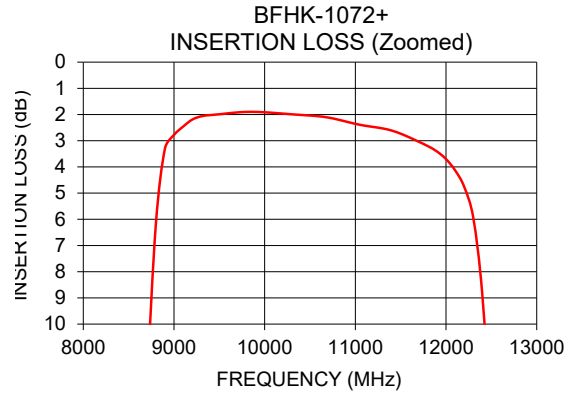
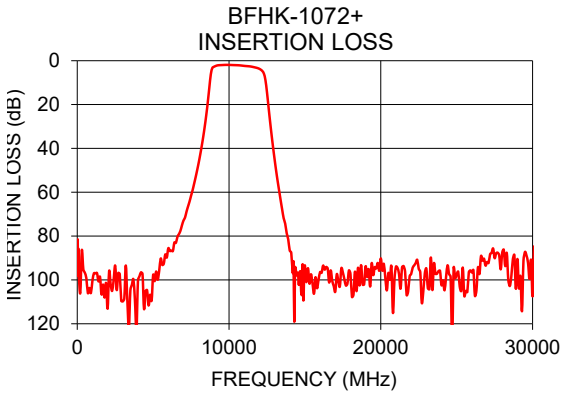

- NOTES**
- A. Performance and quality attributes and conditions not expressly stated in this specification document are intended to be excluded and do not form a part of this specification document.
 - B. Electrical specifications and performance data contained in this specification document are based on Mini-Circuit's applicable established test performance criteria and measurement instructions.
 - C. The parts covered by this specification document are subject to Mini-Circuits standard limited warranty and terms and conditions (collectively, "Standard Terms"); Purchasers of this part are entitled to the rights and benefits contained therein. For a full statement of the standard. Terms and the exclusive rights and remedies thereunder, please visit Mini-Circuits' website at www.minicircuits.com/MCLStore/terms.jsp



Ceramic Bandpass Filter

BFHK-1072+

Typical Performance Data

FREQUENCY (MHz)	INSERTION LOSS (dB)	RETURN LOSS (dB)
10	82.38	0.07
50	98.14	0.09
100	97.93	0.12
500	96.72	0.27
1000	100.34	0.33
1500	98.59	0.32
2000	113.16	0.31
2500	93.48	0.33
3000	109.81	0.40
3500	104.72	0.50
4000	100.31	0.59
4500	105.16	0.58
5000	97.74	0.58
5500	90.22	0.60
6000	85.53	0.68
6500	83.12	0.78
7000	72.90	0.87
7500	61.56	0.93
8000	46.58	1.02
8500	24.82	1.57
9000	2.78	14.40
9200	2.20	24.06
9250	2.20	24.06
9300	2.07	33.85
9350	2.07	33.85
9400	2.02	24.03
9450	2.02	24.03
9500	1.99	22.47
9550	1.99	22.47
9600	1.95	23.33
9650	1.95	23.33
9700	1.92	25.47
9750	1.92	25.47
9800	1.90	28.71
9850	1.90	28.71
9900	1.90	33.53
9950	1.90	33.53
10000	1.91	35.04
10100	1.94	28.51
10200	1.96	24.23
10300	1.99	22.12
10400	2.02	21.66
10500	2.04	23.12
10600	2.07	28.00
10700	2.12	45.54
10800	2.19	25.56
10900	2.27	20.36
11000	2.36	18.14
11100	2.42	17.80
11200	2.48	19.26
11300	2.53	23.50
11500	2.73	27.47
12000	3.70	26.62
13000	44.83	2.38
14000	86.61	1.44
15000	93.34	1.48
15100	101.02	1.49
16000	96.43	1.51
18000	97.22	1.73
20000	90.16	1.64
22000	97.31	1.76
24000	102.43	2.00
26000	96.61	2.00
28000	87.56	2.00
30000	107.52	2.32
32000	78.91	7.77
34000	72.08	3.20
36000	10.48	7.01
38000	42.22	3.29
40000	76.13	3.99



Ceramic Bandpass Filter

BFHK-1072+

Typical Performance Curves

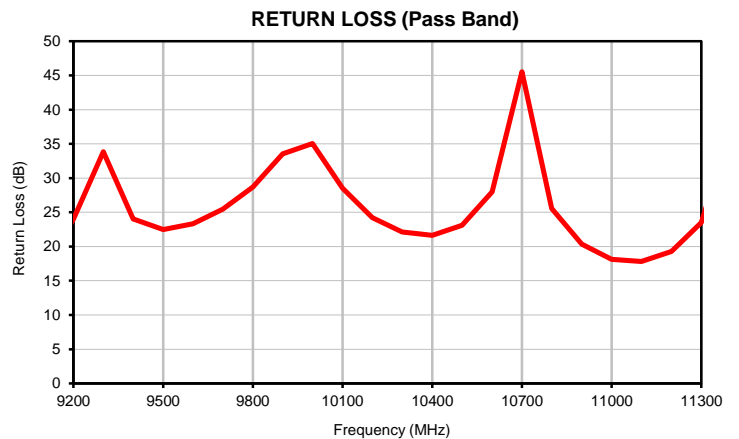
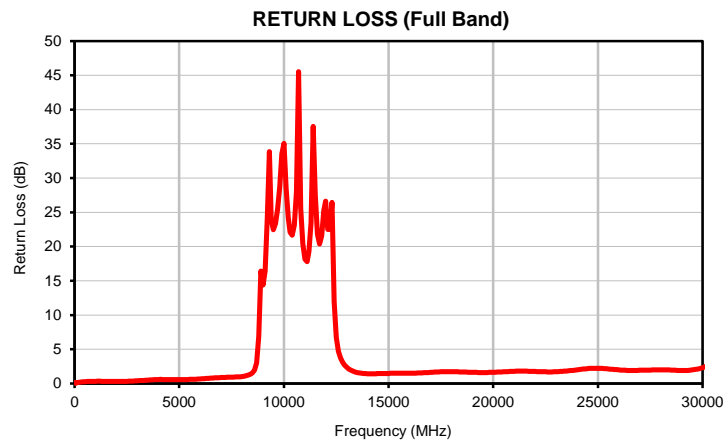
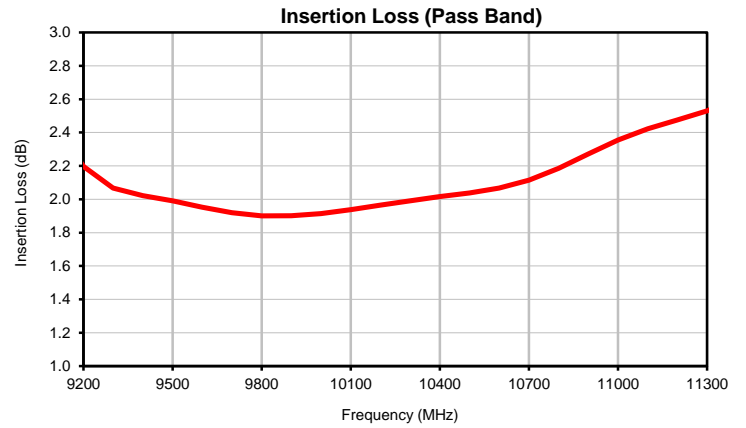
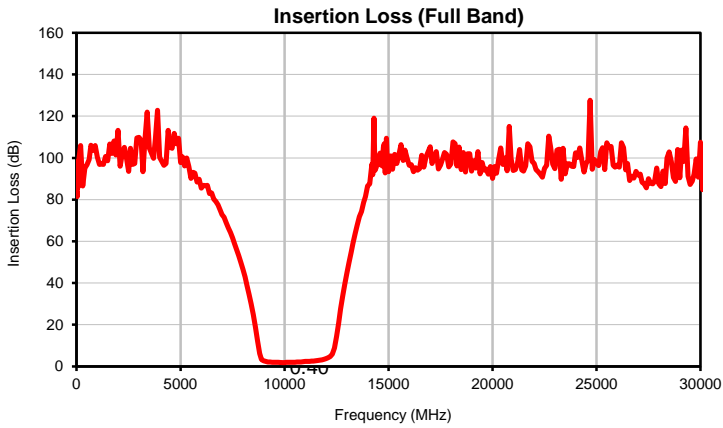

P.O. Box 350166, Brooklyn, New York 11235-0003 (718) 934-4500 • Fax (718) 332-4661 For detailed performance specs & shopping online see Mini-Circuits web site



The Design Engineers Search Engine Provides ACTUAL Data Instantly From MINI-CIRCUITS At: www.minicircuits.com

IF/RF MICROWAVE COMPONENTS

REV. OR
BFHK-1072+
8/6/2021
Page 1 of 1

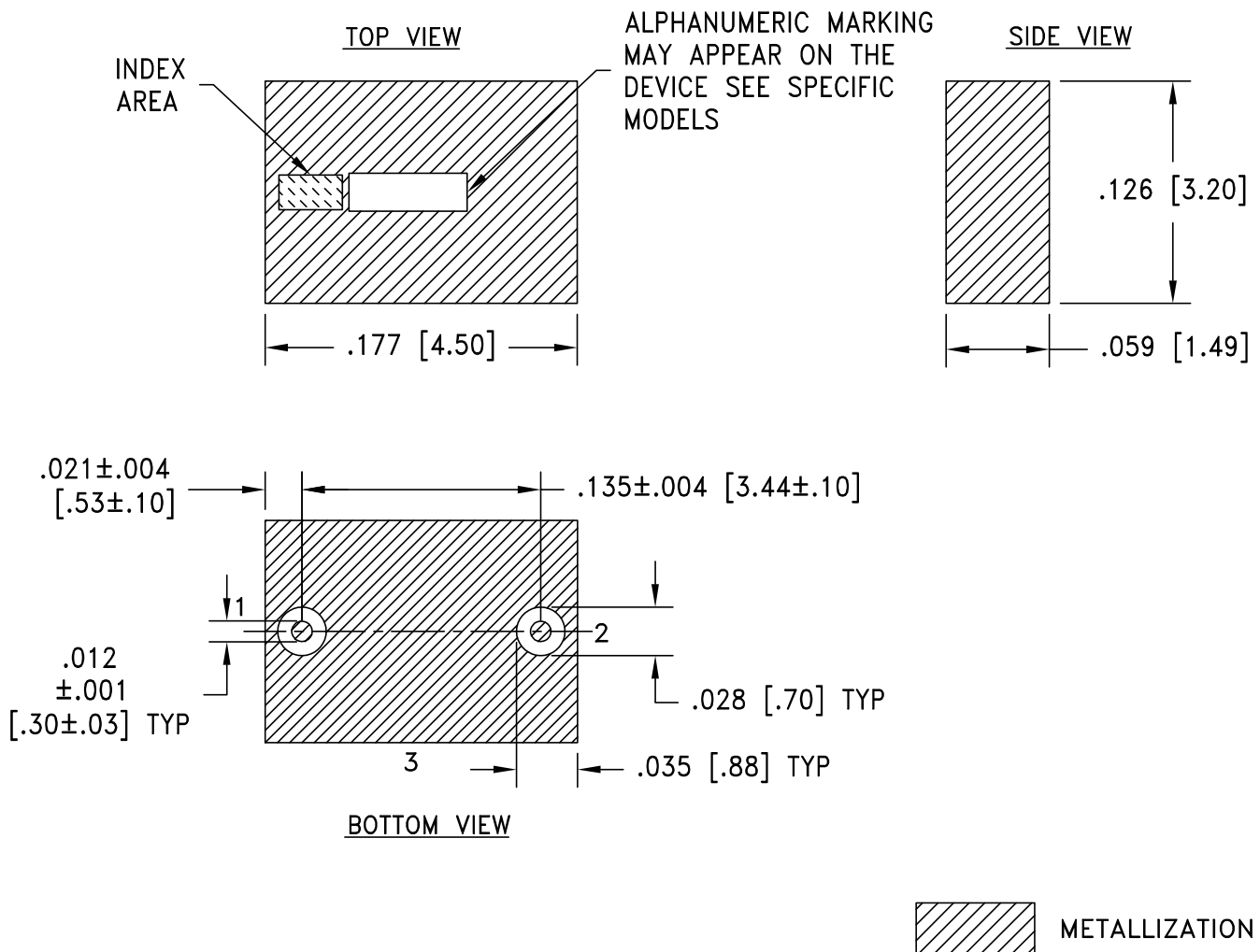

Weight: .126 grams.

Dimensions are in inches [mm]. Tolerances: 2 Pl. $\pm .01$; 3 Pl. $\pm .005$ Inches

Notes:

1. Case material: Ceramic.
2. Termination Finish: **as shown below or indicated on Data Sheet.**
For RoHS Case Styles: Tin Plate over Nickel plate. All models, (+) suffix.

Mini-Circuits®
ISO 9001 ISO 14001 CERTIFIED

ALL NEW
minicircuits.com

P.O. Box 350166, Brooklyn, New York 11235-0003 (718) 934-4500 Fax (718) 332-4661 For detailed performance specs & shopping online see Mini-Circuits web site



The Design Engineers Search Engine Provides ACTUAL Data Instantly From MINI-CIRCUITS At: www.minicircuits.com

RF/IF MICROWAVE COMPONENTS

THIRD ANGLE PROJECTION

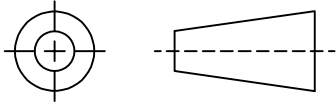

REVISIONS

REV	ECN No.	DESCRIPTION	DATE	DR	AUTH
OR	ECO-013254	NEW RELEASE	05/16/22	ITG	IL
A	ECO-015587	UPDATED STACK-UP DIAGRAM	11/01/22	ITG	IL
B	ECO-020890	ADDED DIMENSIONS	02/16/24	ITG	IL

SUGGESTED MOUNTING CONFIGURATION FOR
NM1812C-3 CASE STYLE

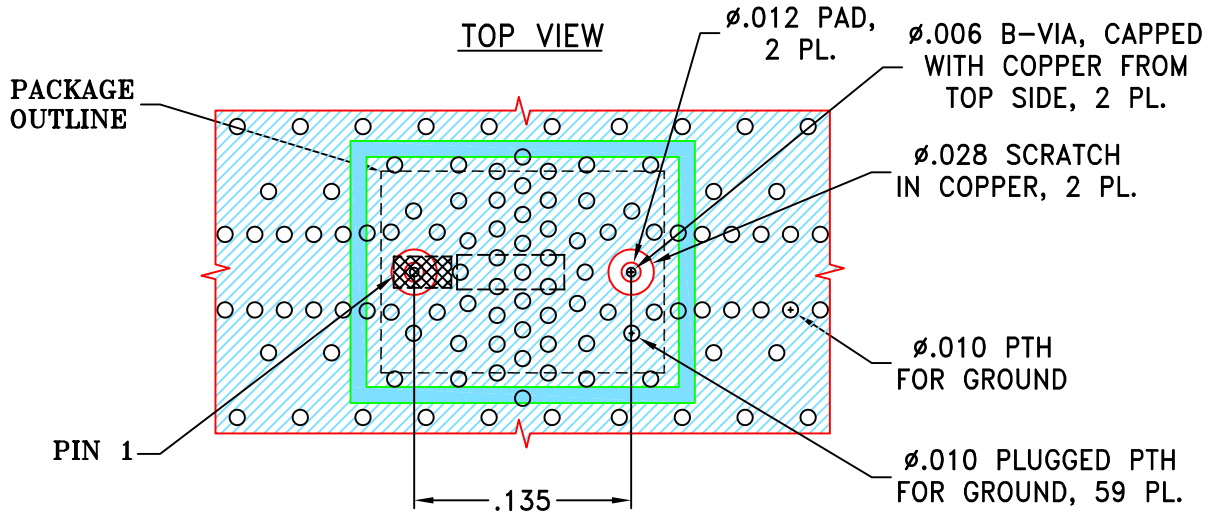

STACK-UP DIAGRAM

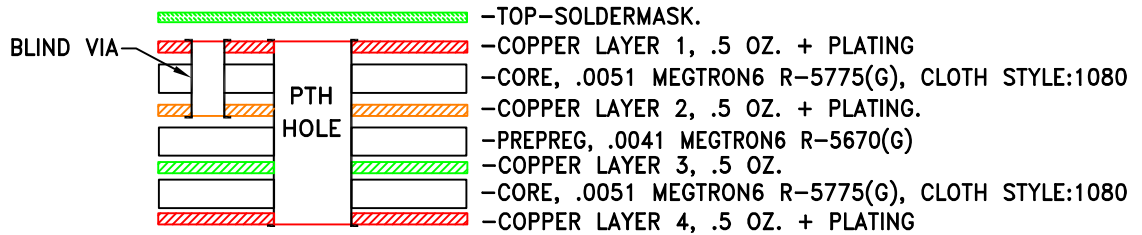

1. TOTAL FINISHED THICKNESS 0.0228±.004.
2. B-VIA PRESENT FROM COPPER LAYER 1 TO COPPER LAYER 2.
3. PTH PRESENT FROM COPPER LAYER 1 TO COPPER LAYER 4.
4. INDICATED PLUGGED PTH'S ARE PLUGGED WITH EPOXY AND CAPPED WITH COPPER FROM TOP SIDE.
5. LAYER 4 IS CONTINUOUS GROUND PLANE.

NOTES:

1. PCB IS MULTILAYER PCB, SEE STACK-UP DIAGRAM.
2. TRACE WIDTH & GAP PARAMETERS ARE SHOWN FOR MEGTRON6 R-5775(G), CLOTH STYLE:1080 WITH DIELECTRIC THICKNESS .0051; COPPER: 1/2 OZ.+PLATING. FOR OTHER MATERIALS TRACE WIDTH AND GAP MAY NEED TO BE MODIFIED.
3. COPPER LAYER 4 OF THE PCB ARE CONTINUOUS GROUND PLANE.



DENOTES PCB COPPER LAYOUT WITH SMOBC (SOLDER MASK OVER BARE COPPER)

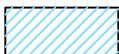

DENOTES COPPER LAND PATTERN FREE OF SOLDER MASK

UNLESS OTHERWISE SPECIFIED	INITIALS		DATE
	DRAWN	ITG	05/16/22
	CHECKED	GF	05/16/22
	APPROVED	IL	05/16/22



Mini-Circuits® 13 Neptune Avenue
Brooklyn NY 11235

PL, NM1812C-3, TB-1239

THIS DOCUMENT AND ITS CONTENTS ARE THE PROPERTY OF MINI-CIRCUITS. EXCEPT FOR USE EXPRESSLY GRANTED, IN WRITING, TO ITS VENDORS, VENDEE AND THE UNITED STATES GOVERNMENT, MINI-CIRCUITS RESERVES ALL PROPRIETARY DESIGN, USE, MANUFACTURING AND REPRODUCTION RIGHTS THERETO. THESE CONTENTS SHALL NOT BE USED, DUPLICATED OR DISCLOSED TO ANY OUTSIDE PARTY, IN WHOLE OR IN PART, WITHOUT WRITTEN PERMISSION OF MINI-CIRCUITS.

SIZE	CODE IDENT	DRAWING NO:	REV:
A	15542	98-PL-730	B
FILE:	98PL730	SCALE: 8:1	SHEET: 1 OF 2

LAYER 2, B-VIA & PTH

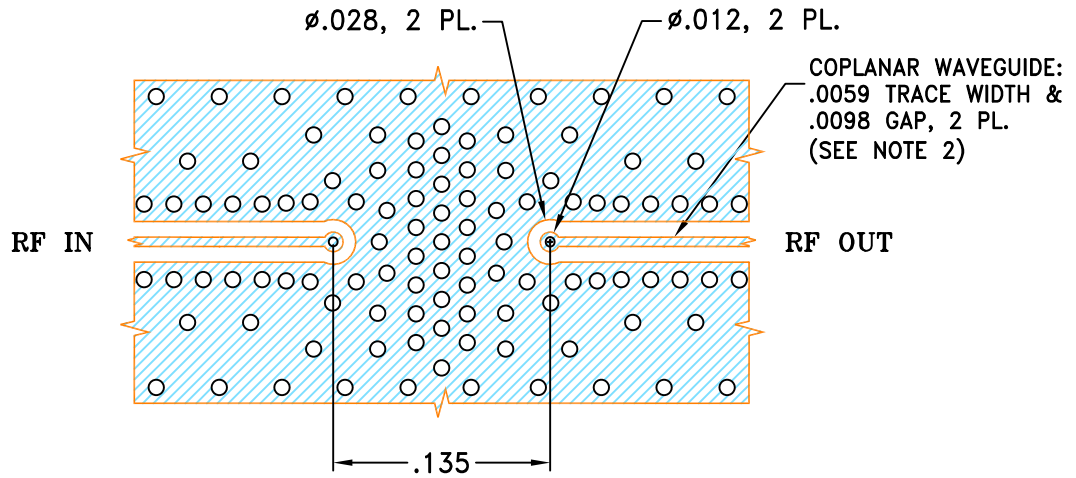

LAYER 3 & PTH

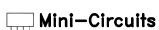
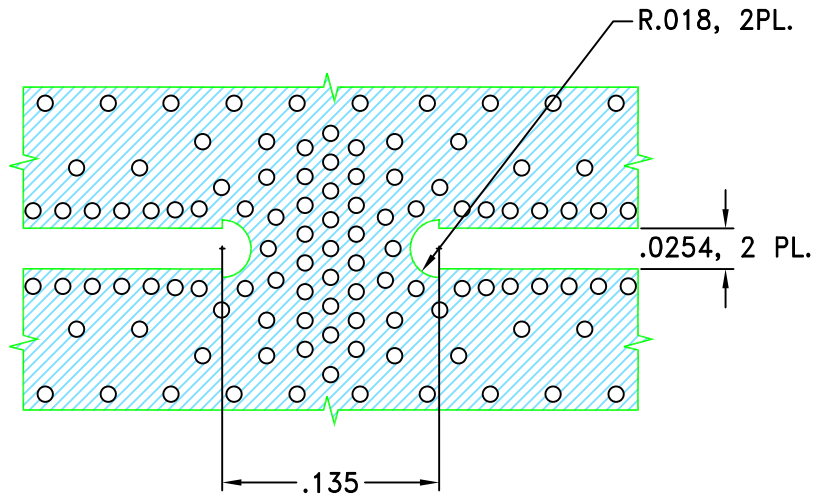

THIS DOCUMENT AND ITS CONTENTS ARE THE PROPERTY OF MINI-CIRCUITS. EXCEPT FOR USE EXPRESSLY GRANTED, IN WRITING, TO ITS VENDORS, VENDEE AND THE UNITED STATES GOVERNMENT, MINI-CIRCUITS RESERVES ALL PROPRIETARY DESIGN, USE, MANUFACTURING AND REPRODUCTION RIGHTS THERETO. THESE CONTENTS SHALL NOT BE USED, DUPLICATED OR DISCLOSED TO ANY OUTSIDE PARTY, IN WHOLE OR IN PART, WITHOUT WRITTEN PERMISSION OF MINI-CIRCUITS.

ALL DIMENSIONS ARE IN INCHES EXCEPT OTHERWISE SPECIFIED

SIZE A	CODE IDENT 15542	DRAWING NO: 98-PL-730	REV: B
FILE: 98PL730	SCALE: 8:1	SHEET: 2 OF 2	

Evaluation Board and Circuit

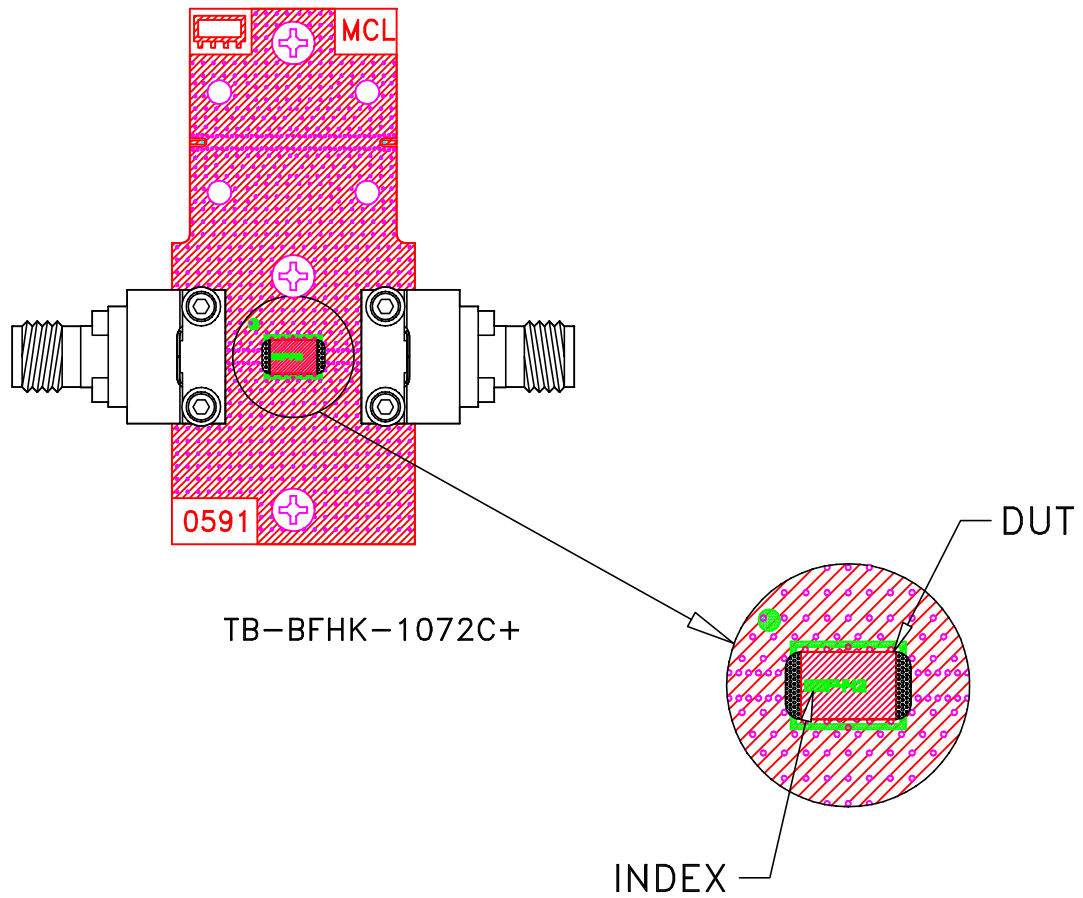

TB-BFHK-1072C+

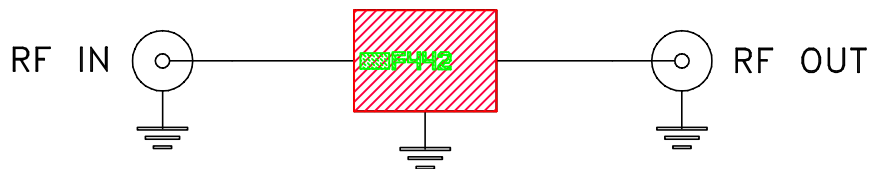

Schematic Diagram

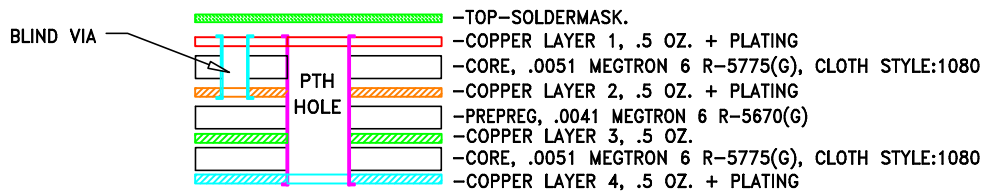

STACK-UP DIAGRAM

Notes:

1. 2.92 mm Female End Launch Connector.
2. PCB Material: Megtron 6 R5775(N).
Dielectric Constant=3.6.
3. Total finished thickness .023".

 **Mini-Circuits®**



Environmental Specifications ENV06T8

All Mini-Circuits products are manufactured under exacting quality assurance and control standards, and are capable of meeting published specifications after being subjected to any or all of the following physical and environmental test.

Specification	Test/Inspection Condition	Reference/Spec
Operating Temperature	-55° to 125° C Ambient Environment	Individual Model Data Sheet
Storage Temperature	-55° to 125° C Ambient Environment	Individual Model Data Sheet
Thermal Cycling	-55 to 125°C, 100 cycles, Dwell Time 15 minutes.	MIL-STD-202, Method 107, Condition A-3
Mechanical Shock	50g, 11ms half-sine, 18 shocks applied each to 3 axes	MIL-STD-202 Method 213, Condition A
Vibration	10-2000Hz sine, 20g, 12 cycles applied each to 3 axes	MIL-STD-202, Method 204, Condition D
Constant Acceleration	30Kg, Y1 Direction	MIL-STD-883, Method 2001, Condition E
Humidity	85°C, 90-95% Relative Humidity, 250hours	
Solderability	10X / 30X Magnification	J-STD-002C Test S, J-STD-002C Test S1
High Temp Storage	125°C, 250 hours	