



CERAMIC

Bandpass Filter

BFCQ-2802+

Mini-Circuits

50Ω 27.5 to 29.5 GHz

THE BIG DEAL

- Innovative and industry leading
- 5G n257 bandpass filter
- Low Insertion Loss – Mid band 2.0dB typical
- Surface mountable pick and place standard case style
- Small size 2.5mm x 2.0mm
- High quality distributed filter topology
- Wide rejection band



Generic photo used for illustration purposes only

CASE STYLE: NL1008C-6

+RoHS Compliant

The +Suffix identifies RoHS Compliance. See our website for methodologies and qualifications

APPLICATIONS

- 5G Telecommunications

PRODUCT OVERVIEW

The BFCQ-2802+ LTCC Bandpass Filter covers the 5G n257 band. This corresponds to a passband of 27.5 to 29.5 GHz, with as low as 2dB passband loss, and up to 40dB stopband rejection. This model handles up to 1W RF input power and provides a wide operating temperature range from -55 to +125°C. Utilizing a proprietary LTCC material system and a distributed filter topology, this filter is able to achieve repeatable performance on a lot-to-lot basis, up to mmWave frequencies.

KEY FEATURES

Feature	Advantages
5G n257 band compatible	Designed for 5G Telecommunications, n257 band, 27.5 – 29.5 GHz
Proprietary mmWave compatible LTCC material system	Low loss and repeatable performance on a lot-to-lot basis up to mmWave frequencies.
Cost effective	LTCC is scalable technology that allows for cost reduction at volume.
Small size (2.5mm x 2.0mm)	Allows for high layout density of circuit boards, while minimizing effects of parasitics.
Surface Mountable	Suitable for very high volume automated assembly process.

REV. A
ECO-015534
BFCQ-2802+
DL/CP/AM
221026





CERAMIC

Bandpass Filter

BFCQ-2802+

Mini-Circuits

50Ω 27.5 to 29.5 GHz

ELECTRICAL SPECIFICATIONS¹ AT 25°C

Parameter	F#	Frequency (GHz)	Min.	Typ.	Max.	Units
Passband	Center Frequency	—	—	28.4	—	GHz
	Insertion Loss	F1-F2	27.5 - 29.2	—	2	—
			29.2 - 29.5	—	2.4	3.4
	Return Loss (In)	F1-F2	27.5 - 29.5	—	13	—
Return Loss (Out)	F1-F2	27.5 - 29.5	—	13	—	dB
Stop Band, Lower	Insertion Loss	DC-F3	0.1 - 20	30	45	—
			20 - 24.2	20	36	—
Stop Band, Upper	Insertion Loss	F4-F5	32.5 - 38	20	34	—
			38 - 48	30	40	—
			48 - 53	20	34	—

1. Measured on Mini-Circuits Test Board TB-BFCQ-2802C+ with feedline losses removed by normalization of S12 and S21 traces to measurement of TB thru-line.

MAXIMUM RATINGS

Parameter	Ratings
Operating Temperature	-55°C to +125°C
Storage Temperature	-55°C to +125°C
RF Power Input	1W

Permanent damage may occur if any of these limits are exceeded.

TYPICAL FREQUENCY RESPONSE

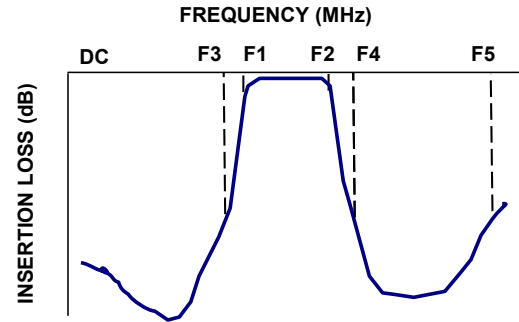

FUNCTIONAL SCHEMATIC

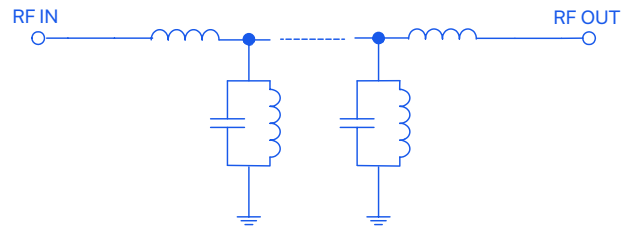



CERAMIC

Bandpass Filter

BFCQ-2802+

Mini-Circuits

50Ω 27.5 to 29.5 GHz

PAD CONNECTIONS

INPUT	1
OUTPUT	2
GROUND	3

PRODUCT MARKING: NT

EVALUATION BOARD MCL P/N: TB-BFCQ-2802C+ SUGGESTED PCB LAYOUT (PL-707)

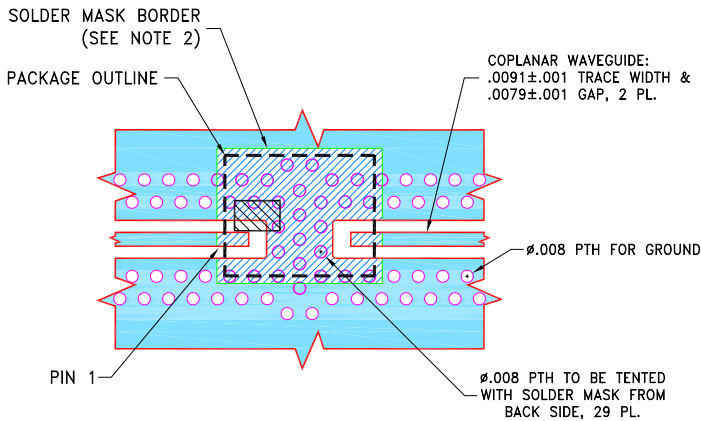

NOTES:

1. COPLANAR WAVEGUIDE PARAMETERS ARE SHOWN FOR MEGTRON-7 R5785(N); DIELECTRIC THICKNESS: .0049±.001; CLOTH STYLE: 2116; COPPER: HVLP/HVLP. FOR OTHER MATERIALS LINE WIDTH & GAP MAY NEED TO BE MODIFIED.
2. SOLDER MASK OPENING FOR COMPONENT SOLDERING HAS BEEN INCREASED AGAINST PCB LAND PATTERN RECOMMENDATIONS PER NL1008C-6 AND CAN BE DEVIATED FROM THIS DRAWING TO COMPLY WITH CUSTOMERS' DESIGN RULES.
3. BOTTOM SIDE OF THE PCB IS CONTINUOUS GROUND PLANE.

- DENOTES PCB COPPER LAYOUT WITH SMOBC (SOLDER MASK OVER BARE COPPER).
- DENOTES COPPER LAND PATTERN FREE OF SOLDER MASK.

OUTLINE DRAWING

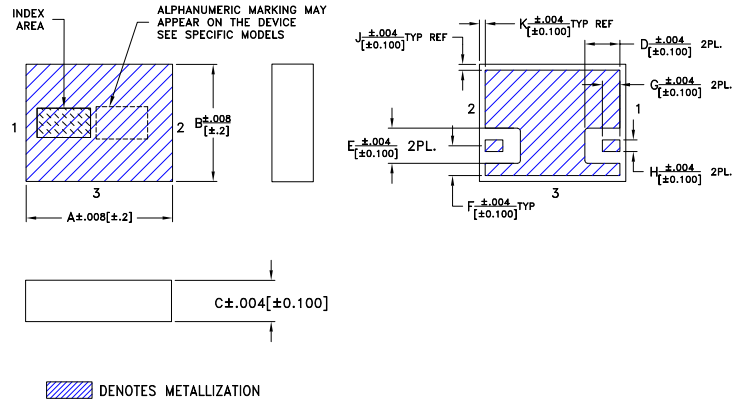

OUTLINE DIMENSIONS (Inches/mm)

A	B	C	D	E	F	G	H	J	K	wt
.098	.079	.028	.024	.024	.020	.012	.008	.004	.004	grams
2.49	2.01	0.71	0.6	0.6	0.51	0.3	0.2	0.1	0.1	.019

TAPE & REEL INFORMATION: F75

Mini-Circuits



CERAMIC

Bandpass Filter

BFCQ-2802+

Mini-Circuits

50Ω 27.5 to 29.5 GHz

TYPICAL PERFORMANCE DATA AT 25°C

Frequency (MHz)	Insertion Loss (dB)	Return Loss (dB)
10	66.98	0.06
3000	70.76	0.42
6000	68.51	0.38
9000	65.69	0.54
15000	65.83	0.80
21000	43.02	1.26
24400	42.08	1.44
27500	1.25	21.77
28400	1.29	13.91
29500	1.82	13.29
35000	34.85	1.83
39000	43.79	1.04
41000	43.18	1.29
44000	44.49	1.44
50000	40.96	1.73

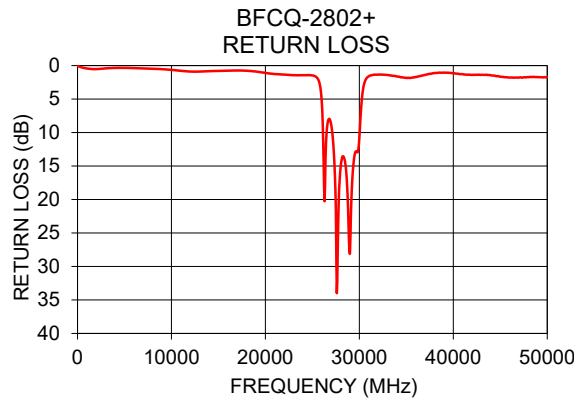
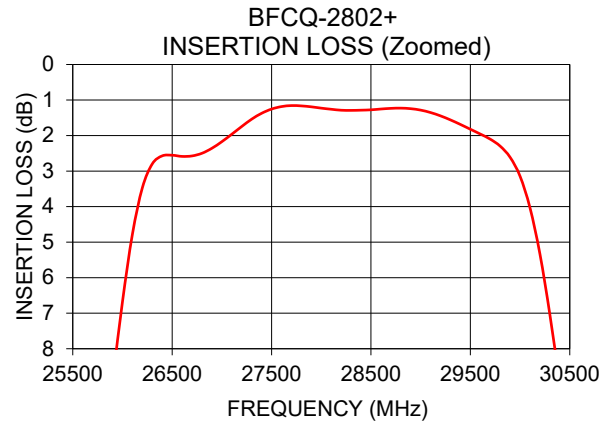
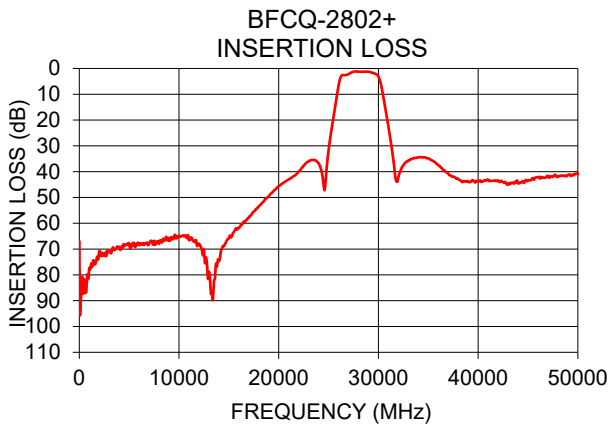

NOTES

- A. Performance and quality attributes and conditions not expressly stated in this specification document are intended to be excluded and do not form a part of this specification document.
- B. Electrical specifications and performance data contained in this specification document are based on Mini-Circuit's applicable established test performance criteria and measurement instructions.
- C. The parts covered by this specification document are subject to Mini-Circuits standard limited warranty and terms and conditions (collectively, "Standard Terms"); Purchasers of this part are entitled to the rights and benefits contained therein. For a full statement of the standard. Terms and the exclusive rights and remedies thereunder, please visit Mini-Circuits' website at www.minicircuits.com/terms/viewterm.html



Typical Performance Data

FREQUENCY (MHz)	INSERTION LOSS (dB)	INPUT RETURN LOSS (dB)	OUTPUT RETURN LOSS (dB)
10	66.98	0.06	0.07
1700	74.46	0.53	0.51
3400	69.37	0.38	0.37
5100	69.81	0.34	0.34
6800	67.47	0.42	0.40
8500	66.25	0.50	0.49
10300	64.95	0.68	0.67
12000	67.88	0.89	0.84
13700	75.70	0.85	0.83
15400	63.94	0.78	0.80
17100	57.16	0.73	0.74
18900	49.85	0.88	0.84
20600	44.00	1.21	1.13
22300	38.60	1.37	1.33
24000	36.80	1.44	1.54
24000	36.80	1.44	1.54
24200	38.60	1.43	1.54
24400	42.08	1.44	1.52
24800	38.95	1.45	1.53
25000	31.63	1.48	1.50
25200	26.03	1.54	1.53
25400	21.06	1.69	1.60
25500	18.65	1.83	1.67
25600	16.23	2.03	1.82
25700	13.80	2.36	2.04
25800	11.35	2.90	2.45
25900	8.94	3.82	3.11
26000	6.68	5.47	4.30
26100	4.78	8.58	6.31
26200	3.47	14.67	8.96
26300	2.80	20.26	10.51
26400	2.57	13.69	9.71
26500	2.55	10.35	8.58
26600	2.59	8.78	7.63
26700	2.57	8.10	7.21
26800	2.50	7.95	7.16
26900	2.36	8.22	7.51
27000	2.17	8.80	8.04
27100	1.96	9.83	8.84
27200	1.74	11.26	10.03
27300	1.54	13.43	11.70
27400	1.37	16.60	13.69
27500	1.25	21.77	15.56
27600	1.18	33.99	17.00
27700	1.16	27.24	17.14
27800	1.17	20.35	16.02
27900	1.19	17.15	14.65
28000	1.23	15.25	13.59
28100	1.26	14.18	13.06
28200	1.29	13.59	12.74
28300	1.29	13.56	12.81
28400	1.29	13.91	13.15
28500	1.28	14.58	13.83
28600	1.25	15.86	14.94
28700	1.23	18.06	16.59
28800	1.23	21.43	18.89
28900	1.24	26.47	20.98
29000	1.28	27.99	21.45
29100	1.35	22.30	19.52
29200	1.45	18.37	17.17
29300	1.56	15.88	15.61
29400	1.69	14.33	14.44
29500	1.82	13.29	14.02
29600	1.96	12.85	14.32
29800	2.30	12.94	19.39
30000	3.15	10.78	18.62
30600	13.44	2.33	2.70
31000	22.61	1.61	1.76
36000	37.51	1.69	1.57
39500	43.43	1.07	1.21
42900	45.05	1.40	1.21
46300	42.02	1.79	1.76
48100	41.91	1.73	1.79
49800	40.76	1.76	1.59
51500	38.96	1.64	1.70
53200	37.05	1.61	1.71
56600	21.33	2.82	2.90
60000	19.89	3.07	3.17



P.O. Box 350166, Brooklyn, New York 11235-0003 (718) 934-4500 • Fax (718) 332-4661 For detailed performance specs & shopping online see Mini-Circuits web site



The Design Engineers Search Engine Provides ACTUAL Data Instantly From MINI-CIRCUITS At: www.minicircuits.com

IF/RF MICROWAVE COMPONENTS

Typical Performance Curves

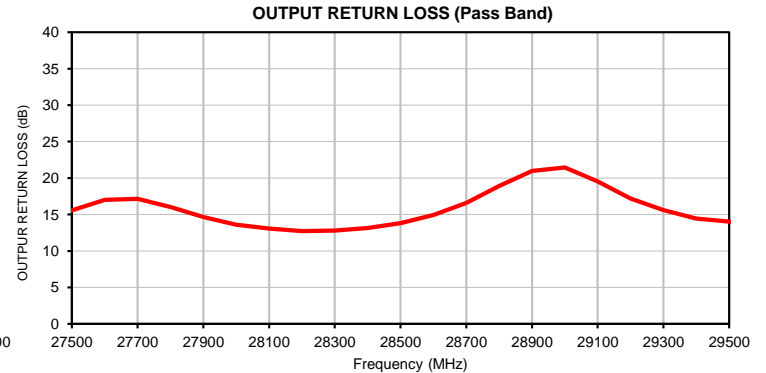
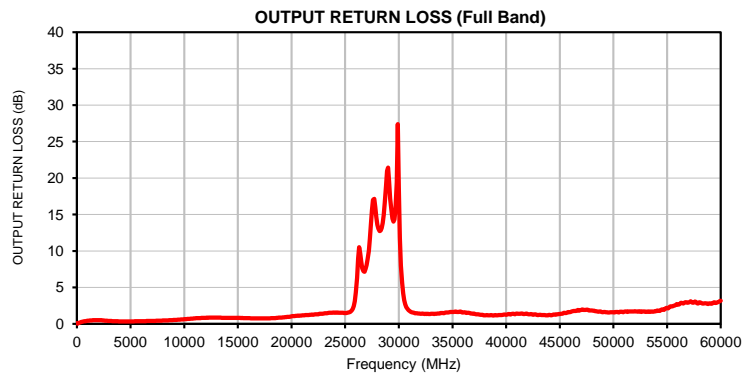
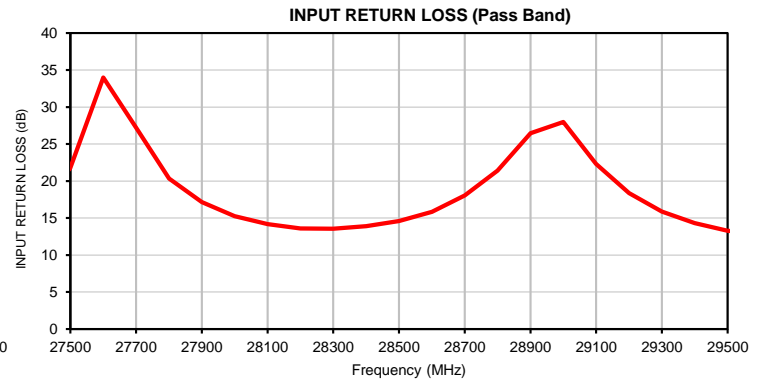
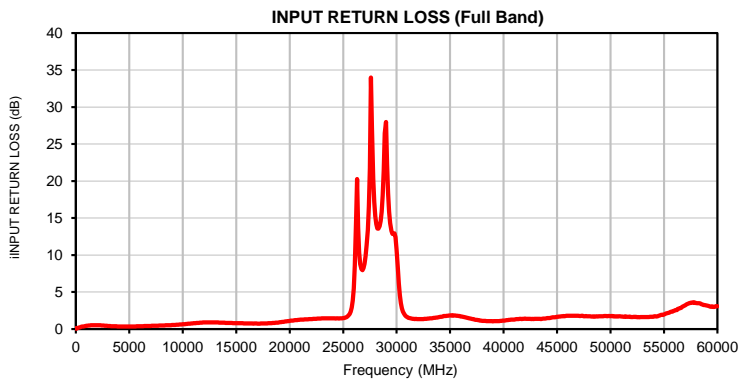
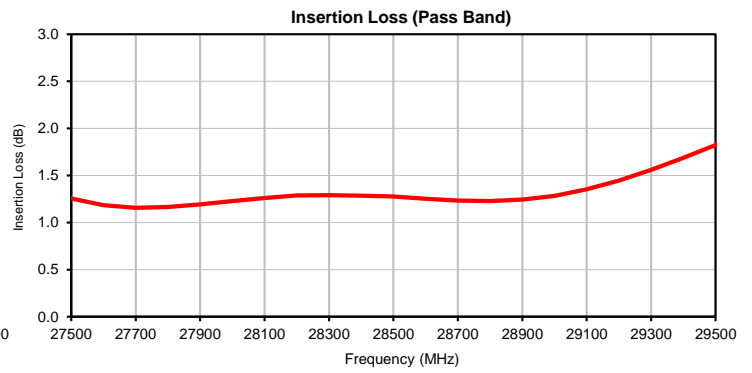
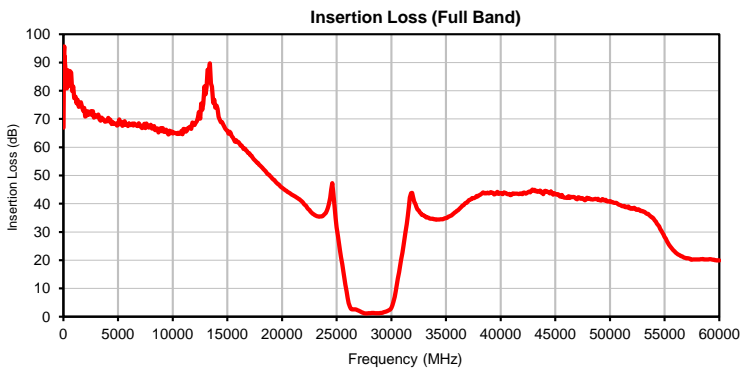

Outline Dimensions

NL1008C-6

INDEX AREA
ALPHANUMERIC MARKING MAY APPEAR ON THE DEVICE SEE SPECIFIC MODELS

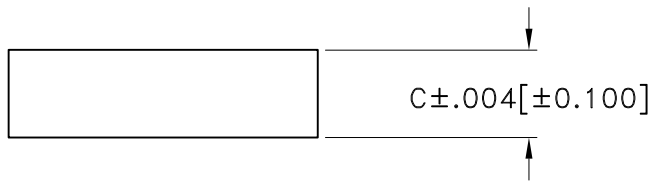
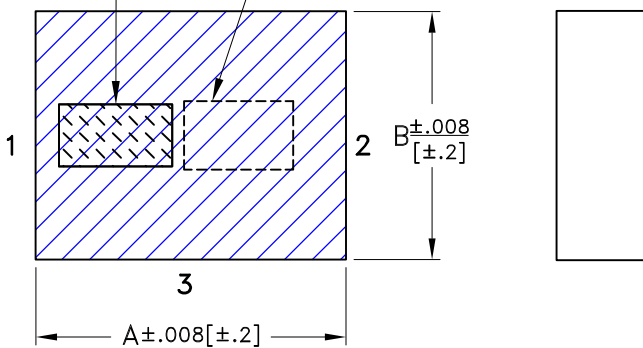

DENOTES METALLIZATION

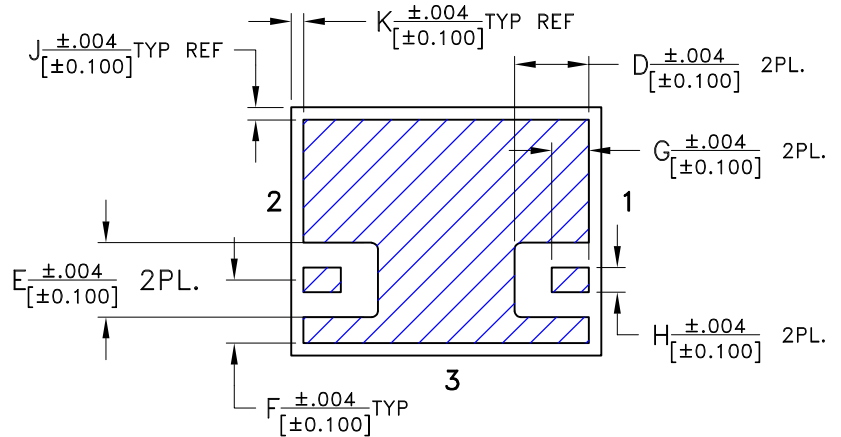

PCB Land Pattern

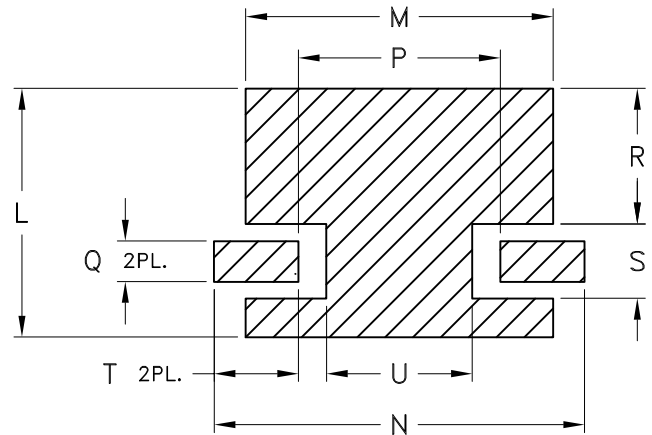

Suggested Layout,
Tolerance to be within $\pm .002$

CASE#	A	B	C	D	E	F	G	H	J	K	L	M	N
NL1008C-6	.098 (2.50)	.079 (2.00)	.028 (.705)	.024 (.60)	.024 (.60)	.020 (.51)	.012 (.30)	.008 (.20)	.004 (.10)	.004 (.10)	.079 (2.0)	.098 (2.5)	.118 (3.0)

CASE #	P	Q	R	S	T	U	WT, GRAM
NL1008C-6	.064 (1.63)	.013 (.3)	.043 (1.09)	.024 (.60)	.027 (.7)	.046 (1.2)	.019

Dimensions are in inches (mm). Tolerances: 2 Pl. $\pm .01$; 3 Pl. $\pm .005$

Notes:

- Open style, ceramic base.
- Termination finish:
For RoHS Case Styles: Tin plate over Nickel plate. All models, (+) suffix.
For RoHS-5 Case Styles: Tin-Lead plate. All models, no (+) suffix.
- Pad tolerance is non-cumulative. Minimum spacing between each pad is .004.
- Line width should be designed to match 50Ω characteristic depending on PCB material and thickness.



P.O. Box 350166, Brooklyn, New York 11235-0003 (718) 934-4500 Fax (718) 332-4661 For detailed performance specs & shopping online see Mini-Circuits web site



The Design Engineers Search Engine Provides ACTUAL Data Instantly From MINI-CIRCUITS At: www.minicircuits.com

RF/IF MICROWAVE COMPONENTS

THIRD ANGLE PROJECTION

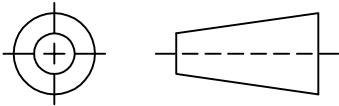

REVISIONS

REV	ECN No.	DESCRIPTION	DATE	DR	AUTH
OR	ECO-007756	NEW RELEASE	05/12/21	ITG	IL

SUGGESTED MOUNTING CONFIGURATION
FOR NL1008C-6 CASE STYLE

SOLDER MASK BORDER
(SEE NOTE 2)

PACKAGE OUTLINE

COPLANAR WAVEGUIDE:
.0091±.001 TRACE WIDTH &
.0079±.001 GAP, 2 PL.

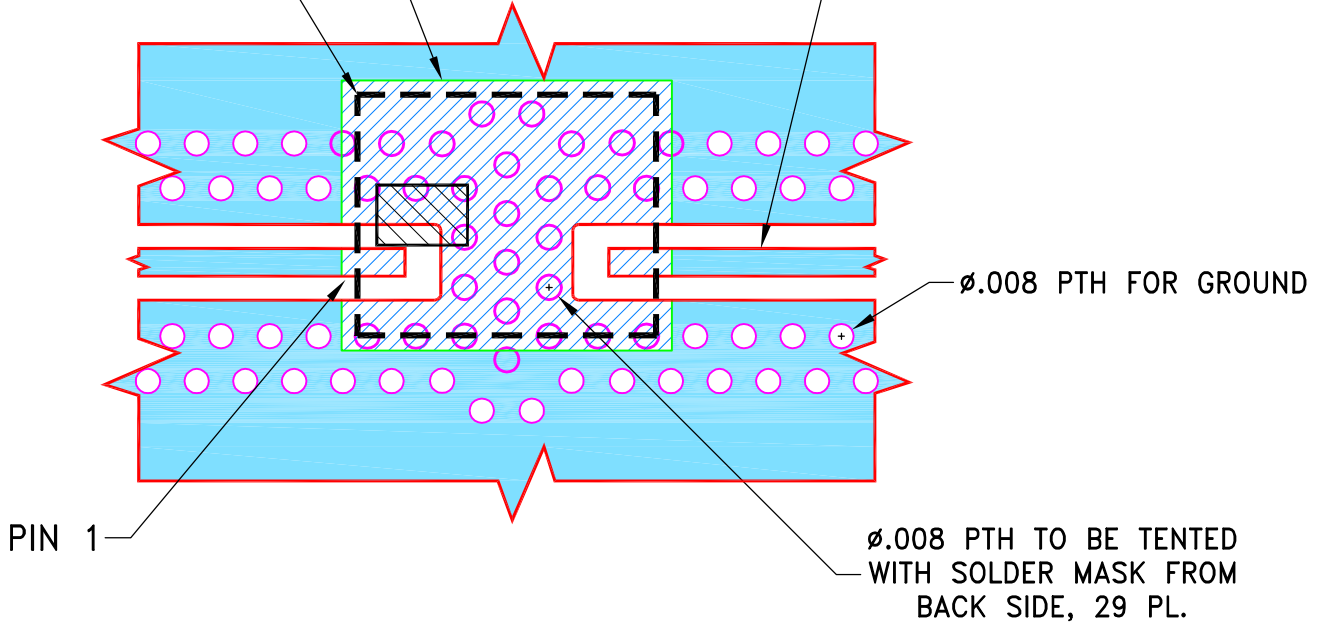

Ø.008 PTH FOR GROUND

Ø.008 PTH TO BE TENTED
WITH SOLDER MASK FROM
BACK SIDE, 29 PL.

NOTES:

1. COPLANAR WAVEGUIDE PARAMETERS ARE SHOWN FOR MEGTRON-7 R5785(N); DIELECTRIC THICKNESS: .0049±.001; CLOTH STYLE: 2116; COPPER: HVLP/HVLP. FOR OTHER MATERIALS LINE WIDTH & GAP MAY NEED TO BE MODIFIED.
2. SOLDER MASK OPENING FOR COMPONENT SOLDERING HAS BEEN INCREASED AGAINST PCB LAND PATTERN RECOMMENDATIONS PER NL1008C-6 AND CAN BE DEVIATED FROM THIS DRAWING TO COMPLY WITH CUSTOMERS' DESIGN RULES.
3. BOTTOM SIDE OF THE PCB IS CONTINUOUS GROUND PLANE.

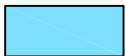

DENOTES PCB COPPER LAYOUT WITH SMOBC (SOLDER MASK OVER BARE COPPER).



DENOTES COPPER LAND PATTERN FREE OF SOLDER MASK.

UNLESS OTHERWISE SPECIFIED	INITIALS		DATE
DIMENSIONS ARE IN INCHES	DRAWN	ITG	05/12/21
TOLERANCES ON:	CHECKED	GF	05/12/21
2 PL DECIMALS ±	APPROVED	IL	05/12/21
3 PL DECIMALS ± .005			
ANGLES ±			
FRACTIONS ±			



Mini-Circuits® 13 Neptune Avenue
Brooklyn NY 11235

PL, NL1008C-6, TB-BFCQ-XXXX+

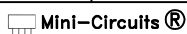

THIS DOCUMENT AND ITS CONTENTS ARE THE PROPERTY OF MINI-CIRCUITS. EXCEPT FOR USE EXPRESSLY GRANTED, IN WRITING, TO ITS VENDORS, VENDEE AND THE UNITED STATES GOVERNMENT, MINI-CIRCUITS RESERVES ALL PROPRIETARY DESIGN, USE, MANUFACTURING AND REPRODUCTION RIGHTS THERETO. THESE CONTENTS SHALL NOT BE USED, DUPLICATED OR DISCLOSED TO ANY OUTSIDE PARTY, IN WHOLE OR IN PART, WITHOUT WRITTEN PERMISSION OF MINI-CIRCUITS.

SIZE	CODE IDENT	DRAWING NO:	REV:
A	15542	98-PL-707	OR
FILE:	98PL707	SCALE: 15:1	SHEET: 1 OF 1

Evaluation Board and Circuit

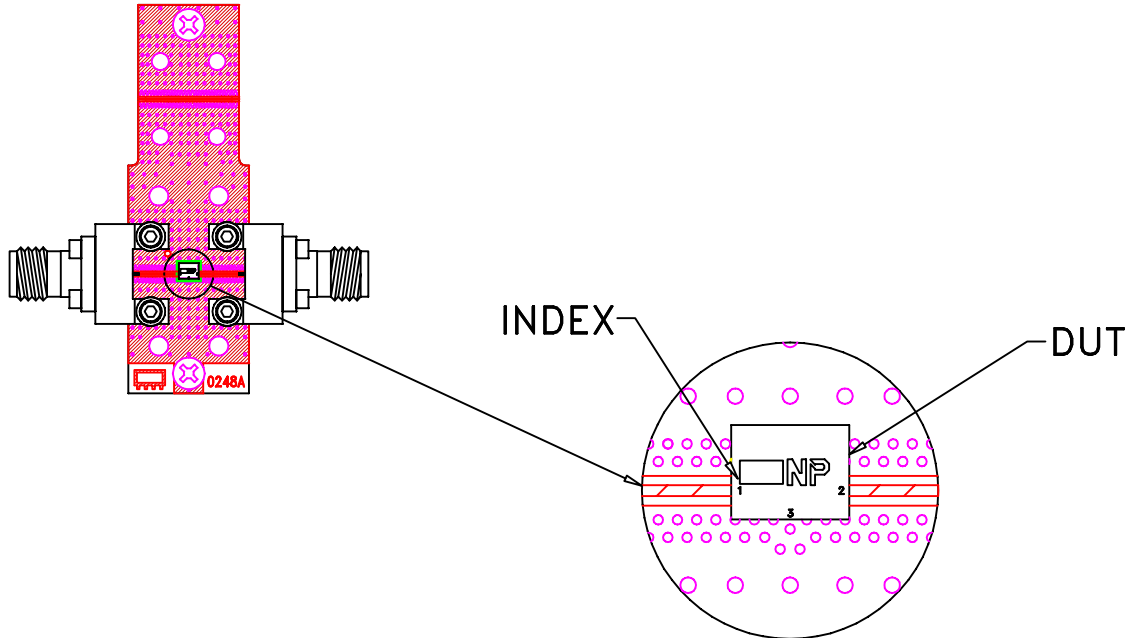

TB-BFCQ-2802C+

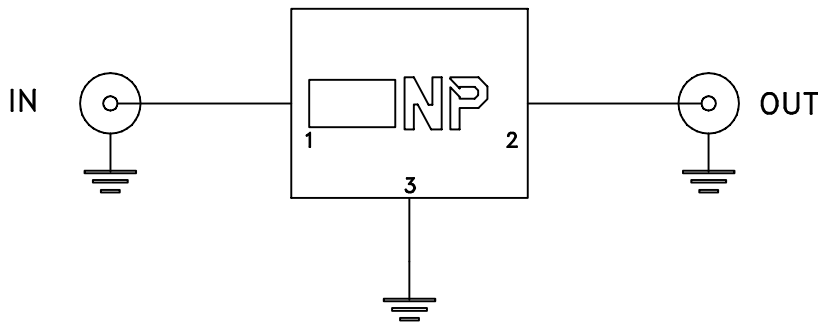

Schematic Diagram

Notes:

1. 50 Ohm 1.85 Female connectors.
2. PCB Material: Megtron 7(N) or equivalent,
Dielectric Constant=3.4, Thickness=.005 inch.

 **Mini-Circuits®**



All Mini-Circuits products are manufactured under exacting quality assurance and control standards, and are capable of meeting published specifications after being subjected to any or all of the following physical and environmental test.

Specification	Test/Inspection Condition	Reference/Spec
Operating Temperature	-55° to 125° C Ambient Environment	Individual Model Data Sheet
Storage Temperature	-55° to 125° C Ambient Environment	Individual Model Data Sheet
Thermal Cycling	-55 to 125°C, 100 cycles, Dwell Time 15 minutes.	MIL-STD-202, Method 107, Condition A-3
Mechanical Shock	50g, 11ms half-sine, 18 shocks applied each to 3 axes	MIL-STD-202 Method 213, Condition A
Vibration	10-2000Hz sine, 20g, 12 cycles applied each to 3 axes	MIL-STD-202, Method 204, Condition D
Constant Acceleration	30Kg, Y1 Direction	MIL-STD-883, Method 2001, Condition E
Humidity	85°C, 90-95% Relative Humidity, 250hours	
Solderability	10X / 30X Magnification	J-STD-002C Test S, J-STD-002C Test S1
High Temp Storage	125°C, 250 hours	