

Ceramic

Bandpass Filter

BFCN-5200+

50Ω 4250 to 6300 MHz

The Big Deal

- LTCC construction
- Temperature stable from -55 to +100°C
- Small size (0.126 x .063 X .037")

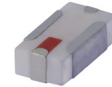

CASE STYLE: FV1206-4

Product Overview

The BFCN-5200+ LTCC bandpass filter covers the 4250 to 6300 MHz passband with 1.8 dB passband insertion loss, 23 dB lower stopband rejection, and 21 dB upper stopband rejection. This model handles up to 2.5W RF input power and provides a wide operating temperature range from -55 to +100°C. Utilizing LTCC multi-layer construction, the filter achieves excellent repeatability of performance and comes in a tiny 1206 ceramic package with wraparound terminations, minimizing performance variations due to parasitics and saving space in dense PCB layouts.

Key Features

Feature	Advantages
LTCC Construction	Provides a rugged package well suited for tough environments such as high humidity and temperature extremes.
Tiny size (0.126 x .063 x .037")	Saves space in dense circuit boards and minimizes the effects of parasitics.
Wrap-around terminations	Provides excellent solderability and easy visual inspection
Wide operating temperature range, -55 to +100°C	Enables reliable performance in extreme environments



Ceramic Bandpass Filter

50Ω 4250 to 6300 MHz

BFCN-5200+

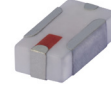

Generic photo used for illustration purposes only

CASE STYLE: FV1206-4

Features

- Small size(0.126 x .063 x .037)
- Temperature stable
- LTCC construction

Applications

- Harmonic rejection
- Transmitters / Receivers

+RoHS Compliant
The +Suffix identifies RoHS Compliance. See our web site for RoHS Compliance methodologies and qualifications

Available Tape and Reel at no extra cost

Reel Size	Devices/Reel
7"	20, 50, 100, 200, 500, 1000, 3000

Specification Definition

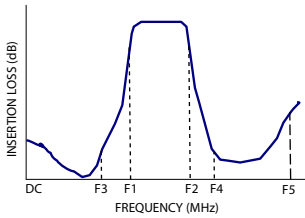

Functional Schematic

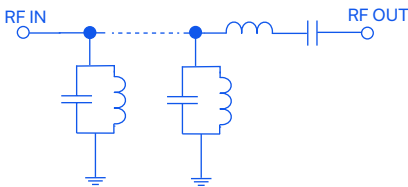

Top View

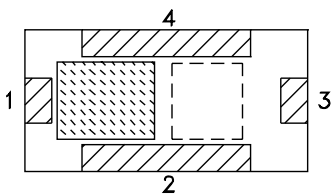

Pad Connections

Input	1
Output	3
Ground	2,4

Electrical Specifications^{1,2} at 25°C

Parameter	F#	Frequency (MHz)	Min.	Typ.	Max.	Unit
Pass Band	Center Frequency	—	—	5200	—	MHz
	Insertion Loss	F1 - F2	4250 - 6300	—	1.8	dB
	VSWR	F1 - F2	4250 - 6300	—	2.3	:1
Stop Band, Lower	Insertion Loss	DC - F3	3300	15	23	dB
	VSWR	DC - F3	3300	—	23	:1
Stop Band, Upper	Insertion Loss	F4 - F5	7500 - 9000	10	21	dB
	VSWR	F4 - F5	7500 - 9000	—	16	:1

1. Measured on Mini-Circuits Characterization Test Board TB-824+.

2. This filter is not intended for use as a DC Blocking circuit element. In Application where DC voltage is present at either input or output ports, blocking capacitors are required at the corresponding RF port.

Maximum Ratings

Operating Temperature	-55°C to +100°C
Storage Temperature	-55°C to +100°C
RF Power Input*	2.5 W at 25°C

*Passband rating, derate linearly to 0.7 W at 100°C ambient
Permanent damage may occur if any of these limits are exceeded.

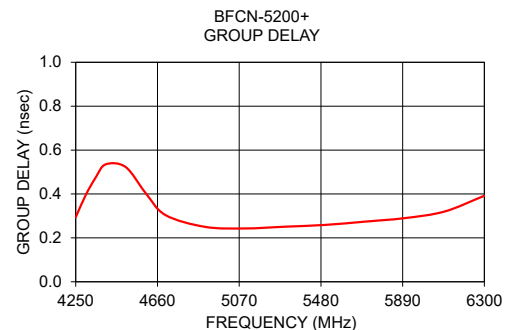
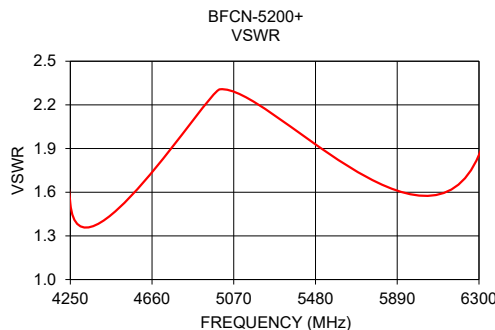
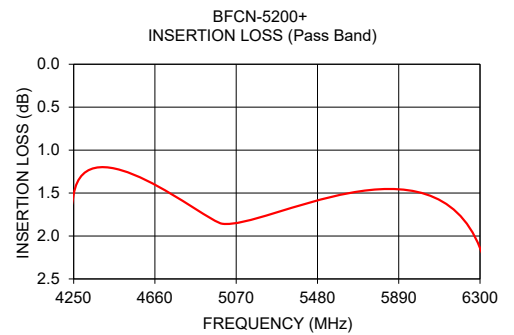
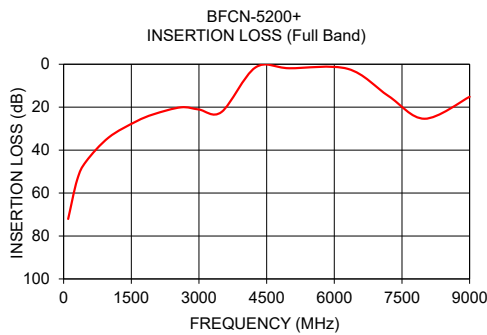

Full Band Performance

Pass Band Performance

Frequency (MHz)	Insertion Loss (dB)	VSWR (:1)	Frequency (MHz)	Insertion Loss (dB)	Group Delay (nsec)
100	72.07	130.26	4250	1.52	0.29
300	53.80	99.00	4300	1.45	0.40
500	45.22	82.81	4350	1.44	0.48
1000	34.09	67.56	4400	1.47	0.54
1600	26.73	59.04	4500	1.56	0.52
2000	23.26	53.49	4600	1.66	0.41
2600	20.06	44.34	4700	1.75	0.30
3000	21.09	37.90	4900	1.85	0.25
3500	22.24	23.85	5100	1.84	0.24
4250	1.52	1.52	5300	1.81	0.25
5000	1.86	2.31	5500	1.79	0.26
6300	2.14	1.86	5700	1.83	0.27
7200	14.79	9.49	5900	1.90	0.29
8000	25.38	23.09	6100	1.98	0.32
9000	15.15	18.38	6300	2.14	0.39

Pad Connections

Input	1
Output	3
Ground	2,4

Product Marking: GC

Outline Drawing

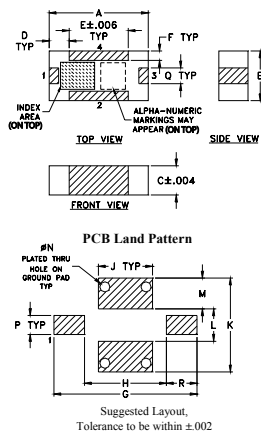

Demo Board MCL P/N: TB-824+ Suggested PCB Layout (PL-454)

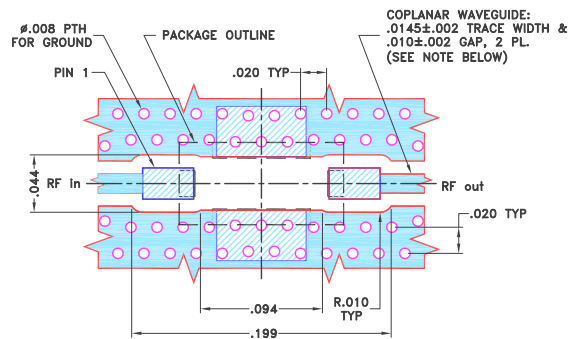

NOTES:

- TRACE WIDTH PARAMETERS ARE SHOWN FOR ROGERS RO4350B WITH DIELECTRIC THICKNESS .0066"±.0007". COPPER: 1/2 OZ. EACH SIDE. FOR OTHER MATERIALS TRACE WIDTH AND GAP MAY NEED TO BE MODIFIED.
- BOTTOM SIDE OF THE PCB IS CONTINUOUS GROUND PLANE.

DENOTES PCB COPPER LAYOUT WITH SMOBC (SOLDER MASK OVER BARE COPPER).
 DENOTES COPPER LAND PATTERN FREE OF SOLDER MASK.

Outline Dimensions (inch mm)

A	B	C	D	E	F	G	H	J	
.126	.063	.037	.026	.075	.012	.182	.104	.069	
3.20	1.60	0.94	0.66	1.91	0.30	4.62	2.64	1.75	
K	L	M	N	P	Q	R		wt	
.119	.041	.039	.013	.024	.020	.039		grams	
3.02	1.04	0.99	0.33	0.61	0.51	0.99		.020	

Additional Notes

- Performance and quality attributes and conditions not expressly stated in this specification document are intended to be excluded and do not form a part of this specification document.
- Electrical specifications and performance data contained in this specification document are based on Mini-Circuit's applicable established test performance criteria and measurement instructions.
- The parts covered by this specification document are subject to Mini-Circuits standard limited warranty and terms and conditions (collectively, "Standard Terms"); Purchasers of this part are entitled to the rights and benefits contained therein. For a full statement of the Standard Terms and the exclusive rights and remedies thereunder, please visit Mini-Circuits' website at www.minicircuits.com/MCLStore/terms.jsp

Typical Performance Data

FREQUENCY (MHz)	INSERTION LOSS (dB)	VSWR (:1)	FREQUENCY (MHz)	GROUP DELAY (ns)
100	72.07	130.26	4250	0.29
200	60.59	109.49	4300	0.40
300	53.80	99.00	4350	0.48
400	48.93	89.48	4400	0.54
500	45.22	82.81	4450	0.55
600	42.24	77.31	4500	0.52
700	39.76	73.78	4550	0.47
800	37.63	72.24	4600	0.41
900	35.75	69.75	4650	0.35
1000	34.09	67.56	4700	0.30
1200	31.23	63.82	4750	0.28
1400	28.82	61.07	4800	0.27
1600	26.73	59.04	4900	0.25
1800	24.88	56.23	5000	0.25
2000	23.26	53.49	5100	0.24
2200	21.87	50.62	5200	0.25
2400	20.76	47.13	5300	0.25
2600	20.06	44.34	5400	0.26
2800	19.99	40.86	5500	0.26
3000	21.09	37.90	5600	0.27
3100	22.49	36.02	5700	0.27
3150	23.56	35.52	5800	0.28
3200	25.09	34.47	5900	0.29
3250	27.26	33.01	6000	0.30
3300	30.41	31.79	6100	0.32
3400	31.27	28.38	6200	0.34
3500	22.24	23.85	6250	0.36
3600	16.37	18.44	6300	0.39
3700	12.00	13.06		
3800	8.47	8.44		
3900	5.64	5.13		
4000	3.58	3.15		
4100	2.29	2.06		
4150	1.90	1.76		
4200	1.65	1.59		
4250	1.52	1.52		
4300	1.45	1.55		
4350	1.44	1.63		
4400	1.47	1.74		
4450	1.51	1.84		
4500	1.56	1.95		
4550	1.61	2.04		
4600	1.66	2.12		
4650	1.71	2.19		
4700	1.75	2.25		
4750	1.79	2.28		
4800	1.82	2.31		
4900	1.85	2.33		
5000	1.86	2.31		
5100	1.84	2.26		
5200	1.82	2.20		
5300	1.81	2.14		
5400	1.79	2.10		
5500	1.79	2.07		
5600	1.81	2.07		
5700	1.83	2.07		
5800	1.85	2.07		
5900	1.90	2.07		
6000	1.94	2.05		
6100	1.98	2.01		
6200	2.04	1.95		
6250	2.09	1.91		
6300	2.14	1.86		
6350	2.19	1.81		
6400	2.29	1.77		
6450	2.40	1.74		
6500	2.54	1.73		
6550	2.74	1.75		
6600	3.01	1.81		
6650	3.33	1.93		
6700	3.78	2.12		
6750	4.33	2.39		
6800	5.00	2.75		
6900	6.76	3.79		
7000	9.02	5.27		
7050	10.31	6.21		
7100	11.71	7.26		
7150	13.20	8.34		
7170	13.82	8.78		
7192	14.52	9.30		
7200	14.79	9.49		
7500	27.21	16.59		
8000	25.38	23.09		
8500	19.10	22.35		
9000	15.15	18.38		

Typical Performance Curves

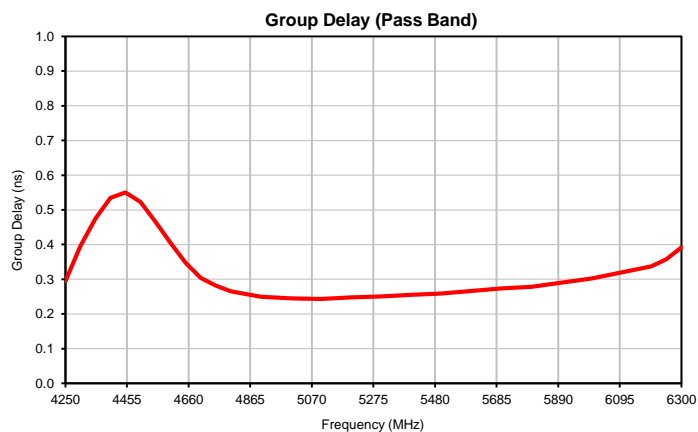
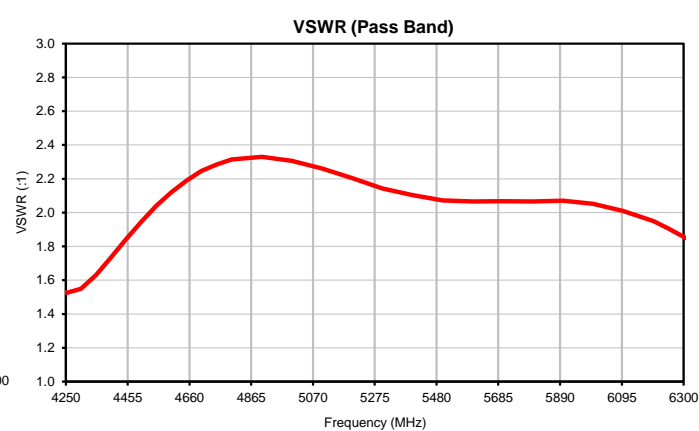
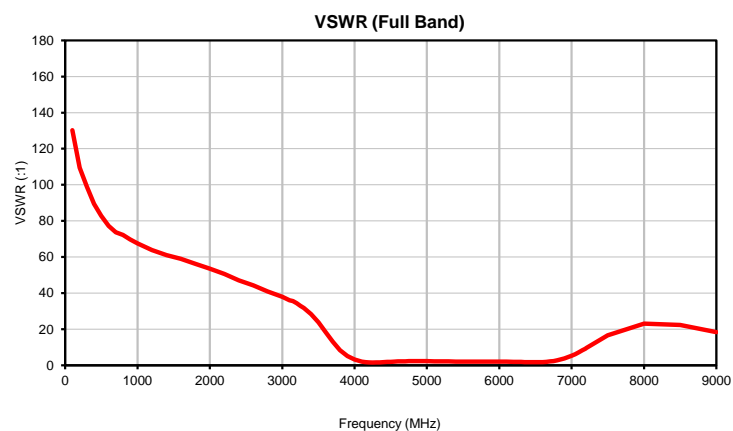
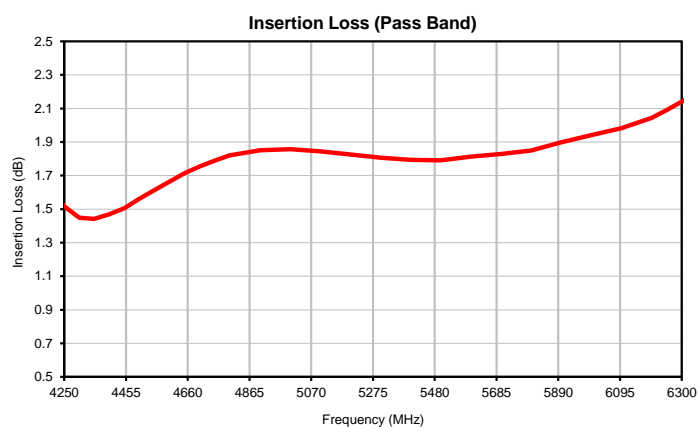
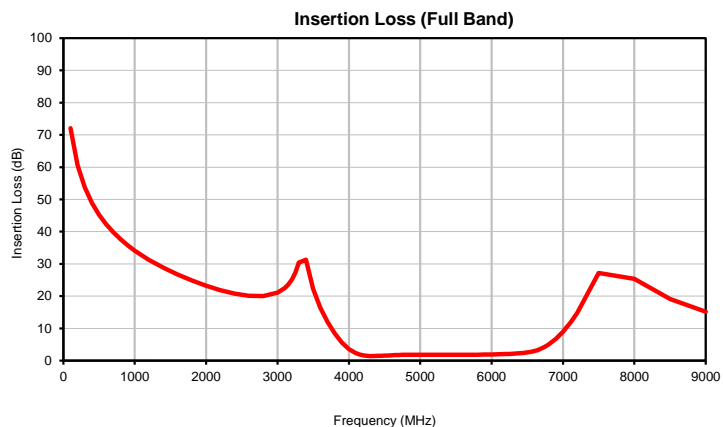

Outline Dimensions

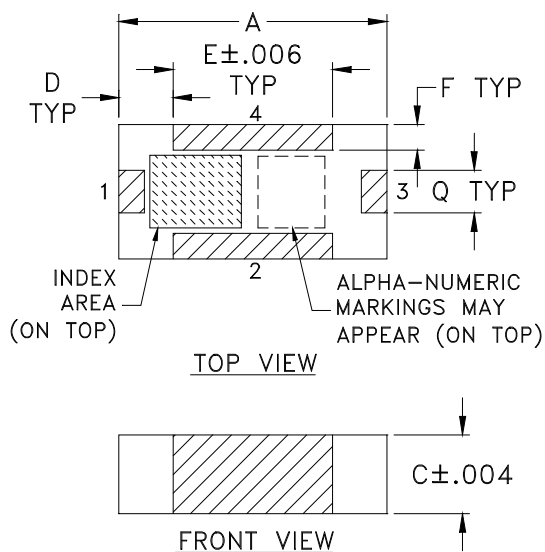

PCB Land Pattern

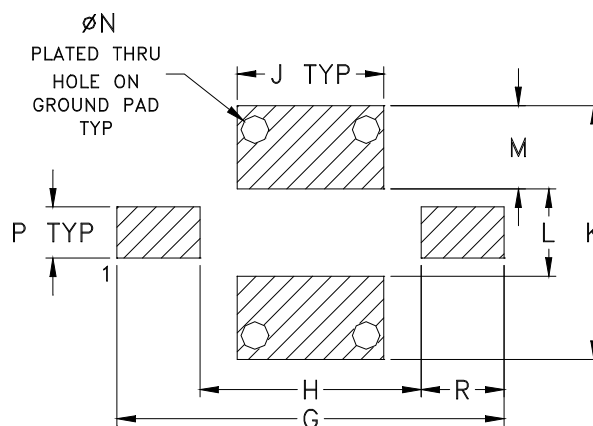

CASE #	A	B	C	D	E	F	G	H	J	K	L	M
FV1206-4	.126 (3.20)	.063 (1.60)	.037 (0.94)	.026 (0.66)	.075 (1.91)	.012 (0.30)	.182 (4.62)	.104 (2.64)	.069 (1.75)	.119 (3.02)	.041 (1.04)	.039 (0.99)

CASE #	N	P	Q	R	WT. GRAM
FV1206-4	.013 (0.33)	.024 (0.61)	.020 (0.51)	.039 (0.99)	.020

Dimensions are in inches (mm). Tolerances: 2 Pl. $\pm .01$; 3 Pl. $\pm .005$

Notes:

- Open style, ceramic base.
- Termination finish: **as shown below or indicated on Data Sheet.**
 For RoHS Case Styles: Tin plate over Nickel plate. All models, (+) suffix.
 For RoHS-5 Case Styles: Tin-Lead plate. All models, no (+) suffix.



P.O. Box 350166, Brooklyn, New York 11235-0003 (718) 934-4500 Fax (718) 332-4661 For detailed performance specs & shopping online see Mini-Circuits web site



The Design Engineers Search Engine Provides ACTUAL Data Instantly From MINI-CIRCUITS At: www.minicircuits.com

RF/IF MICROWAVE COMPONENTS

DEVICE ORIENTATION IN T&R

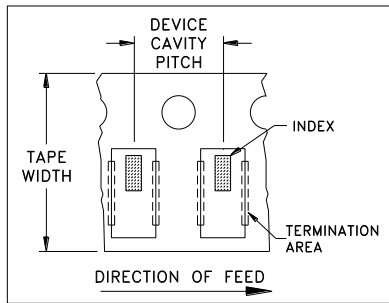

ILLUSTRATION 1

Applicable Case Styles
FV1206-1 FV1206-3

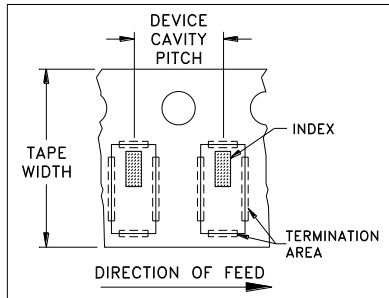

ILLUSTRATION 2

Applicable Case Styles
FV1206-4 FV1206-5 FV1206-6 FV1206-7 FV1206-9

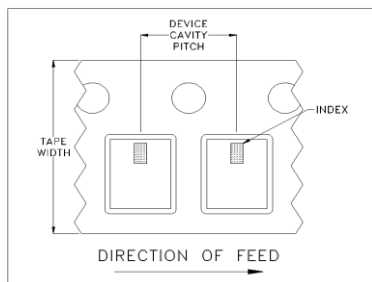

ILLUSTRATION 3

Applicable Case Styles
FV1206-12 GE0805C-18 NL1008C-6 NL1008C-7 NL1008C-9 NL1008C-10

Tape Width, mm	Device Cavity Pitch, mm	Reel Size, inches	Devices per Reel	
8	4	7	Small quantity standards (see note)	20
				50
				100
				200
				500
				1000
			Standard	3000

Note: Please consult individual model data sheet to determine device per reel availability.

Mini-Circuits carrier tape materials provide protection from ESD (Electro-Static Discharge) during handling and transportation. Tapes are static dissipative and comply with industry standards EIA-481/EIA-541.

Go to: www.minicircuits.com/pages/pdfs/tape.pdf

Mini-Circuits ISO 9001 & ISO 14001 Certified

Mini-Circuits[®]

INTERNET <http://www.minicircuits.com>

P.O. Box 350166, Brooklyn, New York 11235-0003 (718) 934-4500 Fax (718) 332-4661

Distribution Centers NORTH AMERICA 800-654-7949 • 417-335-5935 • Fax 417-335-5945 • EUROPE 44-1252-832600 • Fax 44-1252-837010

Mini-Circuits ISO 9001 & ISO 14001 Certified

THIRD ANGLE PROJECTION

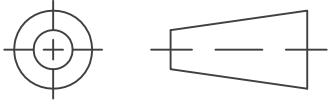

REVISIONS

REV	ECN No.	DESCRIPTION	DATE	DR	AUTH
OR	M152168	NEW RELEASE	07/31/15	ITG	AVB

SUGGESTED MOUNTING CONFIGURATION
FOR FV1206-4 CASE STYLE, "04FL01" PIN CODE

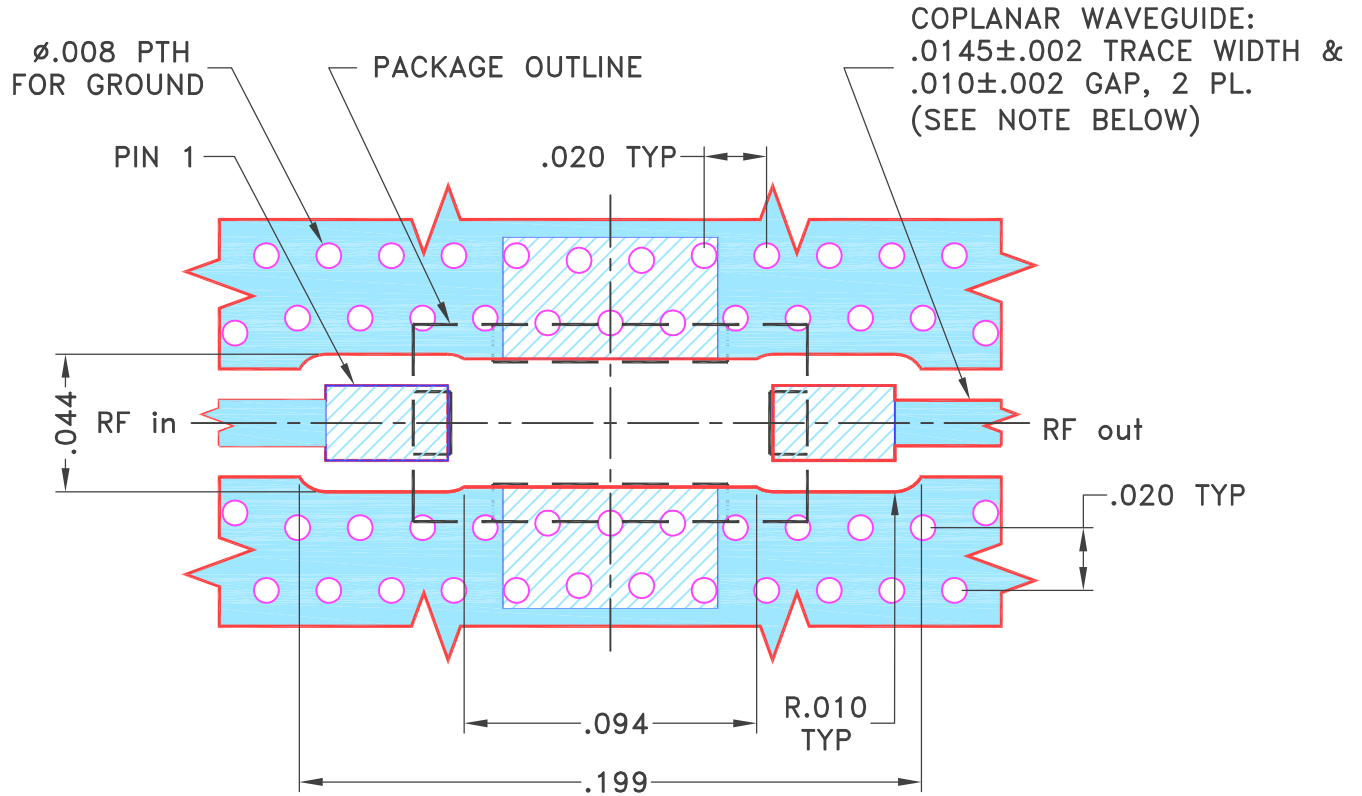

NOTES:

- TRACE WIDTH PARAMETERS ARE SHOWN FOR ROGERS R04350B WITH DIELECTRIC THICKNESS $.0066 \pm .0007$ ". COPPER: 1/2 OZ. EACH SIDE. FOR OTHER MATERIALS TRACE WIDTH AND GAP MAY NEED TO BE MODIFIED.
- BOTTOM SIDE OF THE PCB IS CONTINUOUS GROUND PLANE.

- DENOTES PCB COPPER LAYOUT WITH SMOBC (SOLDER MASK OVER BARE COPPER).
- DENOTES COPPER LAND PATTERN FREE OF SOLDER MASK.

UNLESS OTHERWISE SPECIFIED	INITIALS		DATE
DIMENSIONS ARE IN INCHES TOLERANCES ON: 2 PL DECIMALS ± 3 PL DECIMALS ± .005 ANGLES ± FRACTIONS ±	DRAWN	ITG	07/30/15
	CHECKED	GF	07/31/15
	APPROVED	AVB	07/31/15

Mini-Circuits® 13 Neptune Avenue
 Brooklyn NY 11235

PL, 04FL01, FV1206-4, TB-824+

Mini-Circuits®
 THIS DOCUMENT AND ITS CONTENTS ARE THE PROPERTY OF MINI-CIRCUITS. EXCEPT FOR USE EXPRESSLY GRANTED, IN WRITING, TO ITS VENDORS, VENDEE AND THE UNITED STATES GOVERNMENT, MINI-CIRCUITS RESERVES ALL PROPRIETARY DESIGN, USE, MANUFACTURING AND REPRODUCTION RIGHTS THERETO. THESE CONTENTS SHALL NOT BE USED, DUPLICATED OR DISCLOSED TO ANY OUTSIDE PARTY, IN WHOLE OR IN PART, WITHOUT WRITTEN PERMISSION OF MINI-CIRCUITS.

SIZE A	CODE IDENT 15542	DRAWING NO: 98-PL-454	REV: OR
FILE: 98PL454	SCALE: 16:1	SHEET: 1 OF 1	

Evaluation Board and Circuit

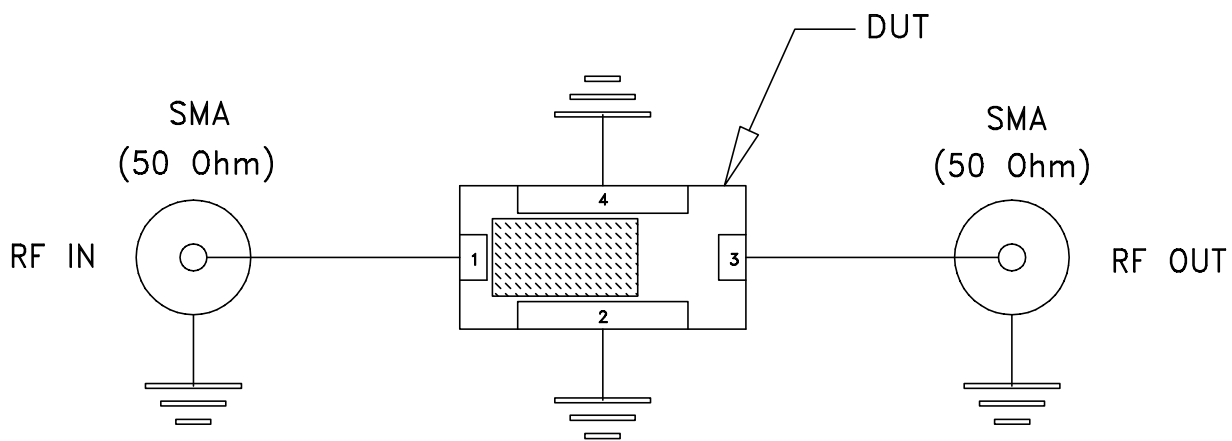
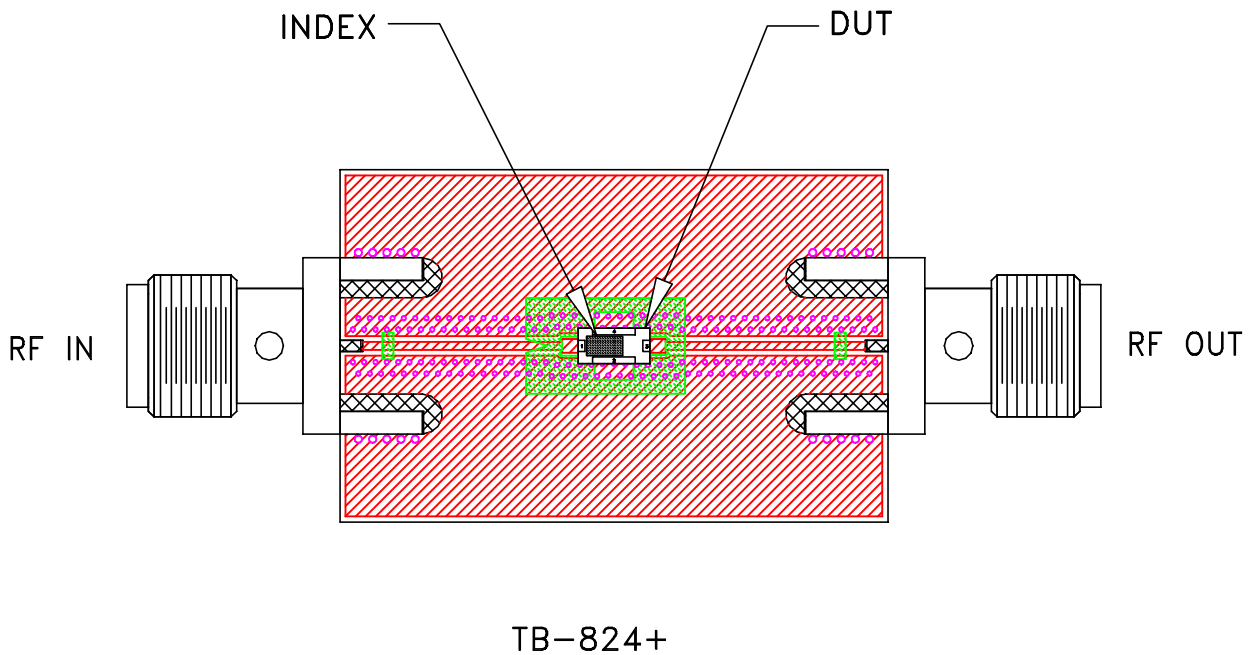

Schematic Diagram

Notes:

1. SMA Female connectors.
2. PCB Material: Rogers R04350 or equivalent,
Dielectric Constant=3.5, Thickness=.0066 inch.

 **Mini-Circuits®**

All Mini-Circuits products are manufactured under exacting quality assurance and control standards, and are capable of meeting published specifications after being subjected to any or all of the following physical and environmental test.

Specification	Test/Inspection Condition	Reference/Spec
Operating Temperature	-40° to 85°C Ambient Environment	Individual Model Data Sheet
Storage Temperature	-55° to 100° C Ambient Environment	Individual Model Data Sheet
Humidity	90 to 95% RH, 240 hours, 50°C	MIL-STD-202, Method 103, Condition A, Except 50°C and end-point electrical test done within 12 hours
Thermal Shock	-55° to 100°C, 100 cycles	MIL-STD-202, Method 107, Condition A-3, except +100°C
Solder Reflow Heat	Sn-Pb Eutetic Process: 225°C peak Pb-Free Process 245° - 250°C peak	J-STD-020, Table 4-1, 4-2 and 5-2, Figure 5-1
Solderability	10X Magnification	J-STD-002, 95% Coverage
Vibration (High Frequency)	20g peak, 10-2000 Hz, 12 times in each of three perpendicular directions (total 36)	MIL-STD-202, Method 204, Condition D
Mechanical Shock	50g, 11 ms, 1/2-sine, 18 shocks: 3 each direction, each of 3 axes	MIL-STD-202, Method 213, Condition A
Marking Resistance to Solvents	Isopropyl alcohol + mineral spirits at 25°C; terpene defluxer at 25°C; distilled water + proylene glycol monomethyl ether + monoethanolamine at 63°C to 70°C	MIL-STD-202, Method 215