



LTCC SMT

Band Pass Filter

BFCN-2850+

Mini-Circuits

50Ω 2750 to 2950 MHz

THE BIG DEAL

- Good Rejection, 25 dB Typ.
- 1206 Surface Mount Footprint
- Power Handling: 1.5 Watts

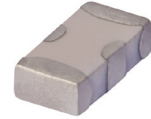

Generic photo used for illustration purposes only

CASE STYLE: FV1206

+RoHS Compliant

The +Suffix identifies RoHS Compliance. See our website for methodologies and qualifications

APPLICATIONS

- Harmonic Rejection
- Transmitters / Receivers
- WiMAX

PRODUCT OVERVIEW

Mini-Circuits' BFCN-2850+ LTCC Band Pass Filter is constructed with multiple layers in order to achieve a miniature size and high repeatability of performance. Wrap-around terminations minimize variations in performance due to parasitics. Covering 200 MHz passband, these units offer low insertion loss and good rejection.

KEY FEATURES

Feature	Advantages
Small Size, 1206	Allows for high layout density of circuit boards, while minimizing the effects of parasitics
Wrap around termination	Provides excellent solderability and easy visual inspection capability.
LTCC construction	Provides a rugged package that is well suited for tough environments including high humidity and high temperature extremes.
Rugged Power handling	Handles up to 1.5 Watts in a small package.

REV. B
ECO-016659
BFCN-2850+
URJ
230202





LTCC SMT

Band Pass Filter

BFCN-2850+

ELECTRICAL SPECIFICATIONS^{1,2} AT 25°C

Parameter	F#	Frequency (MHz)	Min.	Typ.	Max.	Units
Passband	Center Frequency	—	—	2850	—	MHz
	Insertion Loss	F1-F2	2750 - 2950	—	4	dB
	Return Loss	F1-F2	2750 - 2950	10.2	17.7	dB
Stop Band, Lower	Rejection	DC-F3	DC - 1450	—	25	dB
		DC-F4	DC - 1500	20	—	dB
Stop Band, Upper	Rejection	F5-F6	4300 - 4350	20	—	dB
		F6-F7	4350 - 5900	—	25	dB

1. This component should not be used as a DC-block. In applications where DC voltage and/or current is present at either the input or output ports, external DC blocking capacitors are required.
2. Measured on Mini-Circuits Characterization Test Board TB-270.

ABSOLUTE MAXIMUM RATINGS¹

Parameter	Ratings
Operating temperature	-55°C to 100°C
Storage temperature	-55°C to 100°C
RF Power Input ²	1.5W @25°C

1. Permanent damage may occur if any of these limits are exceeded.
2. Power rating applies only to signals within the passband. Power rating above +25°C operating temperature decreases linearly to 0.25W at +100°C.

TYPICAL FREQUENCY RESPONSE

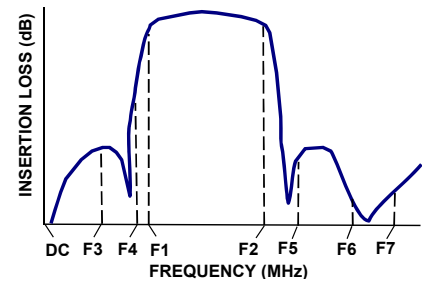

FUNCTIONAL DIAGRAM

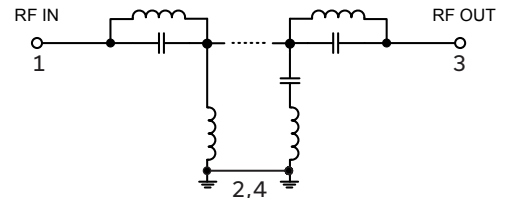



PAD CONNECTIONS

RF IN	1
RF OUT	3
GROUND	2,4

PRODUCT MARKING: RN

DEMO BOARD MCL P/N: TB-270
SUGGESTED PCB LAYOUT (PL-137)

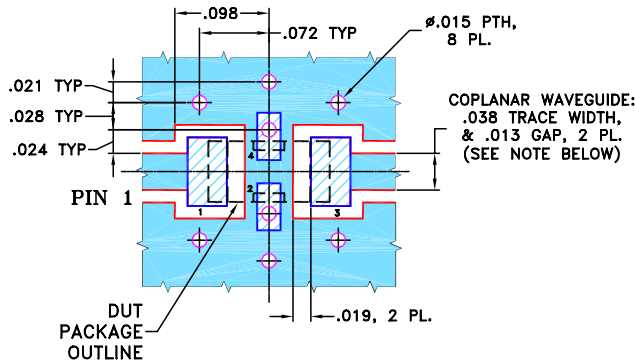

NOTES: 1. COPLANAR WAVEGUIDE PARAMETERS ARE SHOWN FOR ROGERS RO4350B WITH THICKNESS .020" \pm .0015".
COPPER: 1/2 OZ. EACH SIDE.
FOR OTHER MATERIALS TRACE WIDTH & GAP MAY NEED TO BE MODIFIED.

2. BOTTOM SIDE OF THE PCB IS CONTINUOUS GROUND PLANE.
- DENOTES PCB COPPER LAYOUT WITH SMOBC (SOLDER MASK OVER BARE COPPER)
 - DENOTES COPPER LAND PATTERN FREE OF SOLDER MASK

OUTLINE DRAWING

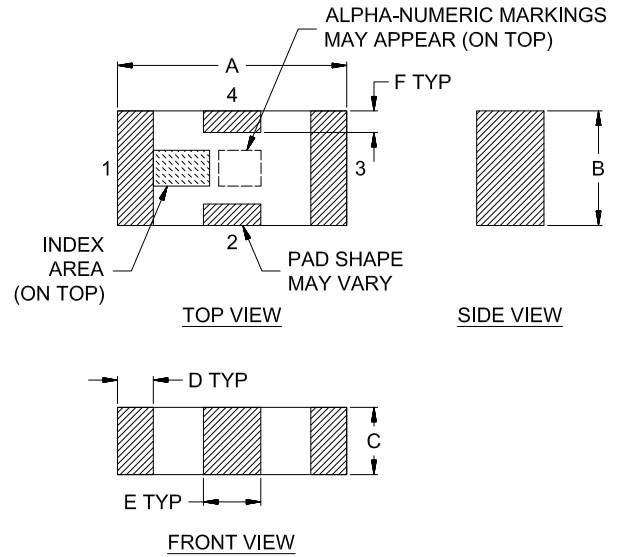

OUTLINE DIMENSIONS (Inches/mm)

A	B	C	D	E	F	Wt.
.126	.063	.037	.020	.032	.009	grams
3.20	1.60	0.94	0.51	0.81	0.23	.020



LTCC SMT

Band Pass Filter

BFCN-2850+

TYPICAL PERFORMANCE DATA AT 25°C

Frequency (MHz)	Insertion Loss (dB)	Return Loss (dB)
50.00	84.92	0.25
1450.00	27.13	0.46
1500.00	26.49	0.46
2421.05	19.60	1.89
2607.46	3.53	12.17
2750.00	1.81	22.18
2795.61	1.70	21.33
2850.00	1.66	21.48
2900.88	1.68	21.68
2950.00	1.75	21.66
3115.79	3.17	13.22
3305.26	21.10	2.38
4300.00	38.21	0.59
4350.00	36.79	0.57
5100.00	29.60	0.43
5900.00	21.49	0.52

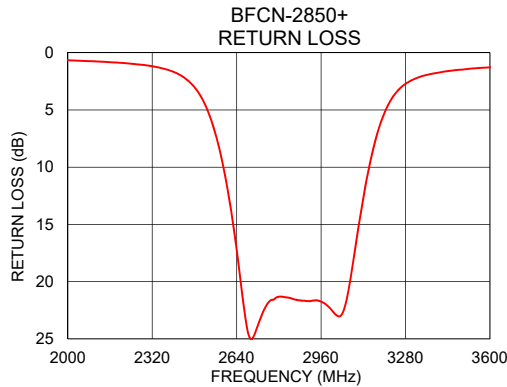
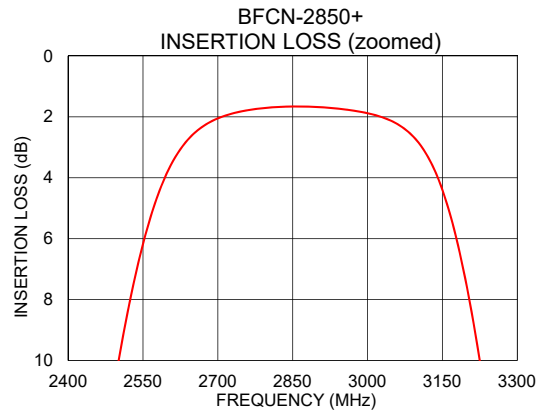
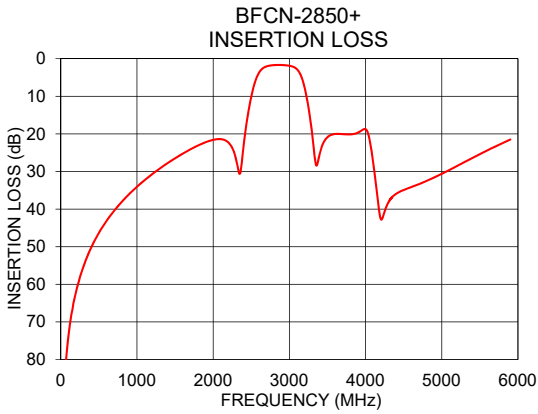

- NOTES**
- A. Performance and quality attributes and conditions not expressly stated in this specification document are intended to be excluded and do not form a part of this specification document.
 - B. Electrical specifications and performance data contained in this specification document are based on Mini-Circuit's applicable established test performance criteria and measurement instructions.
 - C. The parts covered by this specification document are subject to Mini-Circuits standard limited warranty and terms and conditions (collectively, "Standard Terms"); Purchasers of this part are entitled to the rights and benefits contained therein. For a full statement of the standard. Terms and the exclusive rights and remedies thereunder, please visit Mini-Circuits' website at www.minicircuits.com/MCLStore/terms.jsp



Ceramic Band Pass Filter

BFCN-2850+

Typical Performance Data

FREQ. (MHz)	INSERTION LOSS (dB)			INPUT RETURN LOSS (dB)			OUTPUT RETURN LOSS (dB)		
	@ -55° C	@ +25° C	@ +100° C	@ -55° C	@ +25° C	@ +100° C	@ -55° C	@ +25° C	@ +100° C
50	84.59	85.56	85.41	0.05	0.07	0.08	0.00	0.00	0.00
60	82.32	82.09	81.57	0.06	0.08	0.09	0.01	0.00	0.00
80	77.14	76.82	77.19	0.07	0.09	0.10	0.01	0.00	0.00
90	75.12	75.28	74.97	0.07	0.09	0.11	0.01	0.00	0.01
200	61.55	61.44	61.25	0.11	0.14	0.15	0.06	0.01	0.02
400	49.72	49.45	49.44	0.14	0.18	0.20	0.25	0.03	0.04
500	45.86	45.54	45.54	0.14	0.20	0.22	0.37	0.04	0.05
600	42.70	42.33	42.31	0.15	0.21	0.24	0.49	0.04	0.06
800	37.77	37.23	37.25	0.16	0.23	0.27	0.75	0.05	0.08
900	35.68	35.12	35.12	0.17	0.24	0.29	0.86	0.07	0.10
1000	33.72	33.18	33.12	0.18	0.26	0.30	0.97	0.09	0.12
1200	30.24	29.70	29.63	0.20	0.28	0.34	1.08	0.12	0.16
1400	27.11	26.68	26.58	0.21	0.31	0.38	1.05	0.13	0.17
1450	26.41	25.97	25.94	0.21	0.32	0.39	1.01	0.14	0.19
1500	25.72	25.31	25.23	0.22	0.33	0.41	0.96	0.14	0.19
1600	24.31	24.00	23.89	0.24	0.36	0.44	0.87	0.18	0.23
1800	21.65	21.51	21.41	0.31	0.43	0.54	0.67	0.30	0.35
1900	20.46	20.37	20.35	0.35	0.49	0.60	0.54	0.34	0.39
2000	19.44	19.41	19.55	0.42	0.57	0.68	0.46	0.39	0.46
2200	18.49	18.65	18.86	0.63	0.83	0.97	0.41	0.53	0.62
2400	25.37	26.21	26.62	1.07	1.39	1.62	0.84	0.98	1.19
2510	15.58	13.48	12.30	2.06	2.65	3.16	1.93	2.18	2.73
2580	7.57	6.60	6.12	4.15	5.17	6.12	4.27	4.80	5.93
2600	6.16	5.35	5.02	5.09	6.30	7.35	5.37	6.05	7.37
2650	3.71	3.37	3.32	8.46	9.80	10.97	9.35	10.09	11.86
2750	1.96	2.02	2.19	15.50	15.37	16.10	19.14	17.89	18.77
2800	1.73	1.84	2.03	16.34	15.82	16.19	17.05	17.12	17.13
2850	1.76	1.82	2.08	16.04	15.47	16.05	14.39	15.62	15.33
2900	1.72	1.83	2.06	14.71	15.03	15.34	13.32	14.89	14.88
2950	1.77	1.90	2.15	14.19	15.21	15.43	13.47	15.66	16.02
3000	1.86	2.04	2.34	14.35	15.85	15.94	15.60	19.55	21.29
3100	2.71	3.45	4.17	10.94	9.73	8.79	16.50	12.19	10.73
3200	7.79	9.84	11.34	3.51	3.18	3.12	3.74	3.26	3.08
3400	28.04	25.53	24.92	1.08	1.32	1.50	0.82	0.90	1.02
3500	21.96	21.17	21.17	0.99	1.22	1.41	0.67	0.68	0.83
3600	20.36	19.91	20.02	0.94	1.17	1.34	0.60	0.58	0.71
3800	18.39	18.30	18.33	0.91	1.12	1.26	1.07	1.20	1.66
3900	16.16	16.84	17.72	1.01	1.20	1.32	4.45	7.38	11.53
4000	21.61	25.49	28.07	0.89	1.02	1.11	4.38	3.10	2.50
4200	47.24	41.10	41.07	0.69	0.88	0.97	0.29	0.19	0.30
4300	40.66	37.44	37.84	0.62	0.83	0.93	0.09	0.08	0.14
4400	35.51	35.40	35.21	0.56	0.78	0.86	0.09	0.13	0.13
4500	32.30	35.20	33.14	0.60	0.73	0.88	0.27	0.19	0.28
4600	34.35	34.94	37.47	0.51	0.68	0.79	0.15	0.20	0.22
4800	33.64	33.52	32.52	0.47	0.64	0.77	0.05	0.13	0.23
5000	32.88	31.36	33.35	0.39	0.65	0.77	0.06	0.24	0.31
5200	31.39	30.69	29.68	0.32	0.54	0.79	0.19	0.43	0.60
5400	26.60	27.01	26.21	0.40	0.54	0.76	0.29	0.45	0.65
5500	26.70	26.15	26.61	0.46	0.62	0.77	0.30	0.44	0.56
5600	25.49	24.99	25.58	0.48	0.69	0.90	0.31	0.46	0.59
5800	23.48	23.76	23.85	0.53	0.72	1.00	0.51	0.60	0.71
5900	21.68	22.06	22.16	0.58	0.72	0.98	0.62	0.67	0.90

REV. X1
BFCN-2850+
100729
Page 1 of 1



IF/RF MICROWAVE COMPONENTS • ISO 9001 ISO 14001 AS 9100 CERTIFIED • RoHS compliant
P.O. Box 350166, Brooklyn, New York 11235-0003 (718) 934-4500 Fax (718) 332-4661



The Design Engineers Search Engine finds the model you need, Instantly • For detailed performance specs & shopping online see



Typical Performance Curves

INSERTION LOSS vs. TEMPERATURE

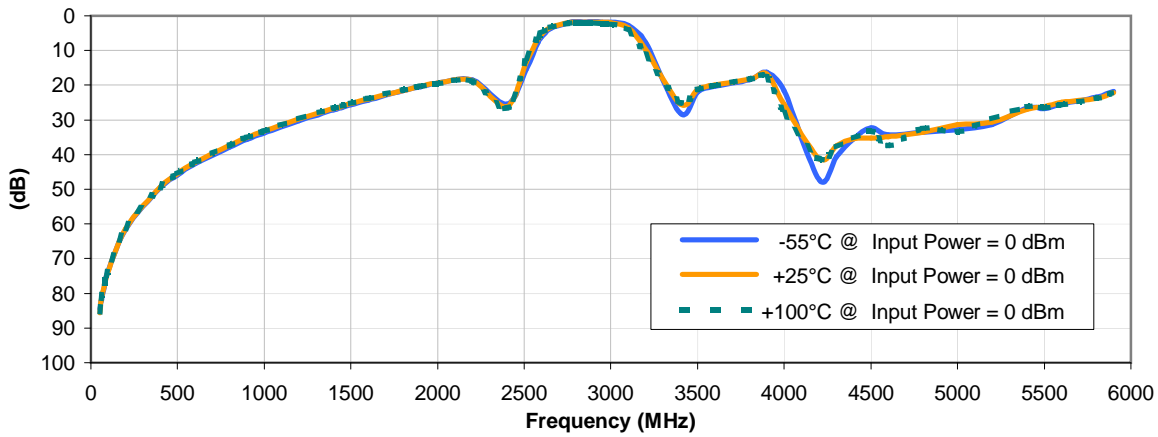

INPUT RETURN LOSS vs. TEMPERATURE

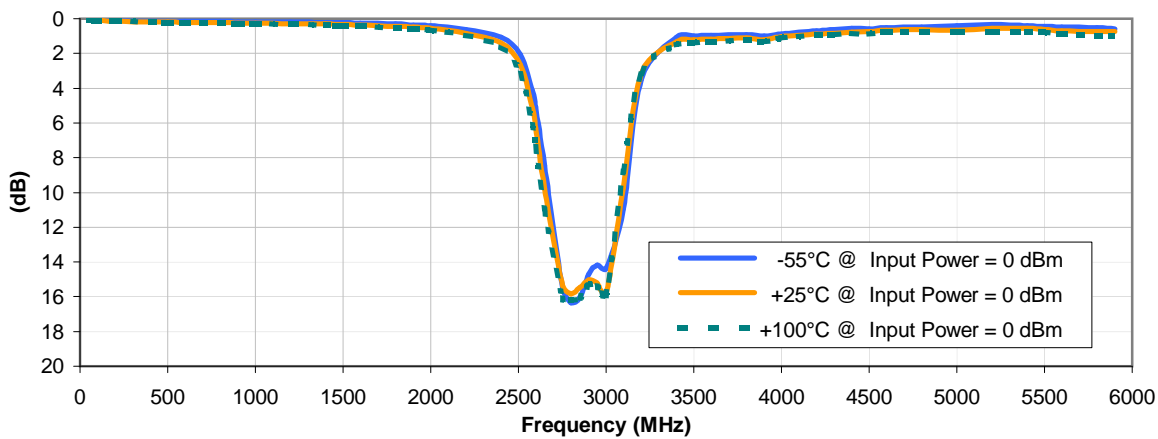

OUTPUT RETURN LOSS vs. TEMPERATURE

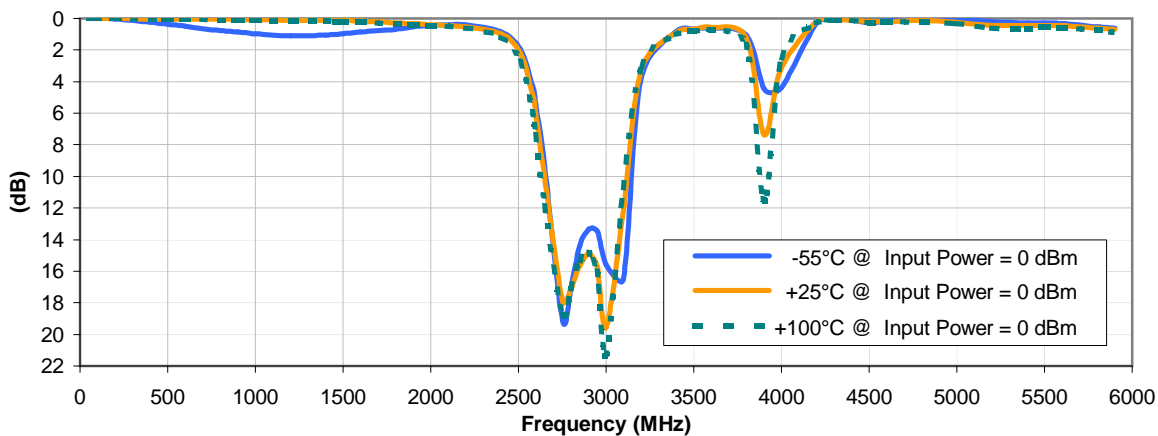

Outline Dimensions

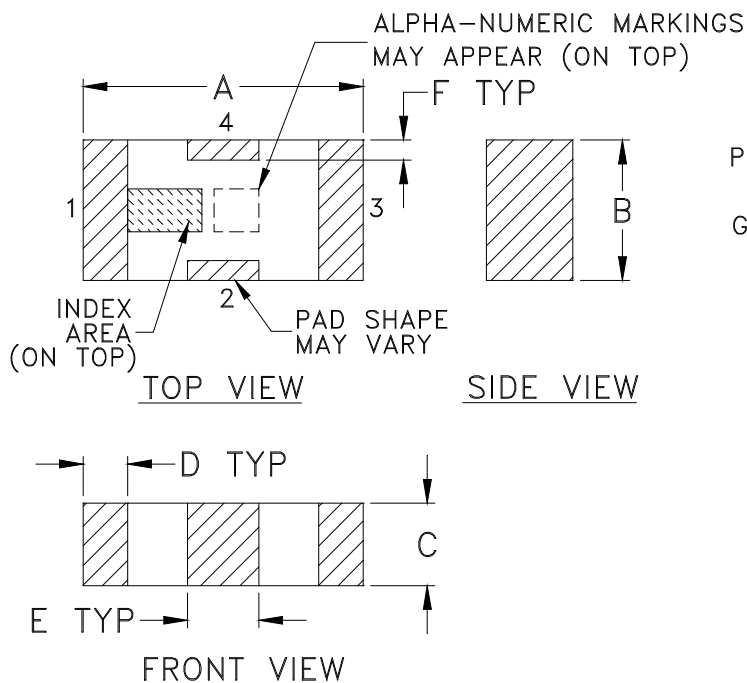

PCB Land Pattern

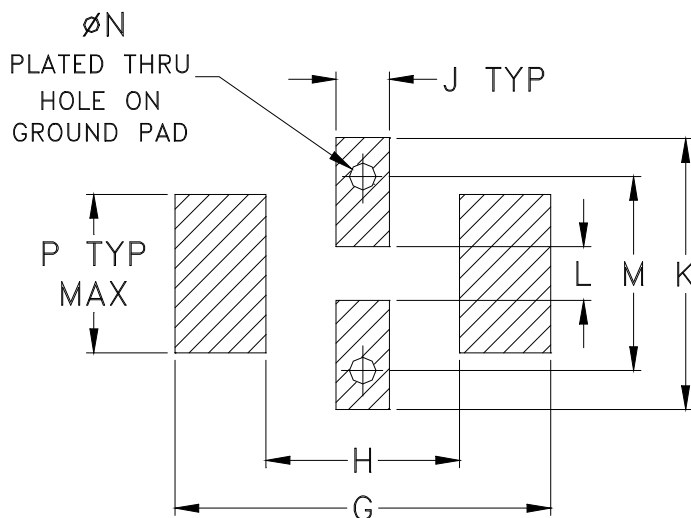

Suggested Layout,
Tolerance to be within $\pm .002$

CASE #	A	B	C	D	E	F	G	H	J	K	L	M	N	P	WT. GRAM
FV1206	.126 (3.20)	.063 (1.60)	.037 (0.94)	.020 (0.51)	.032 (0.81)	.009 (0.23)	.169 (4.29)	.087 (2.21)	.024 (0.61)	.122 (3.10)	.024 (0.61)	.087 (2.21)	.012 (0.30)	.071 (1.80)	.020

Dimensions are in inches (mm). Tolerances: 2 Pl. $\pm .01$; 3 Pl. $\pm .005$

Notes:

1. Open style, ceramic base.
2. Termination finish: **as shown below or indicated on Data Sheet.**
For RoHS Case Styles: Tin plate over Nickel plate. All models, (+) suffix.
For RoHS-5 Case Styles: Tin-Lead plate. All models, no (+) suffix.



P.O. Box 350166, Brooklyn, New York 11235-0003 (718) 934-4500 Fax (718) 332-4661 For detailed performance specs & shopping online see Mini-Circuits web site



The Design Engineers Search Engine Provides ACTUAL Data Instantly From MINI-CIRCUITS At: www.minicircuits.com

RF/IF MICROWAVE COMPONENTS

Tape & Reel Packaging TR-F71

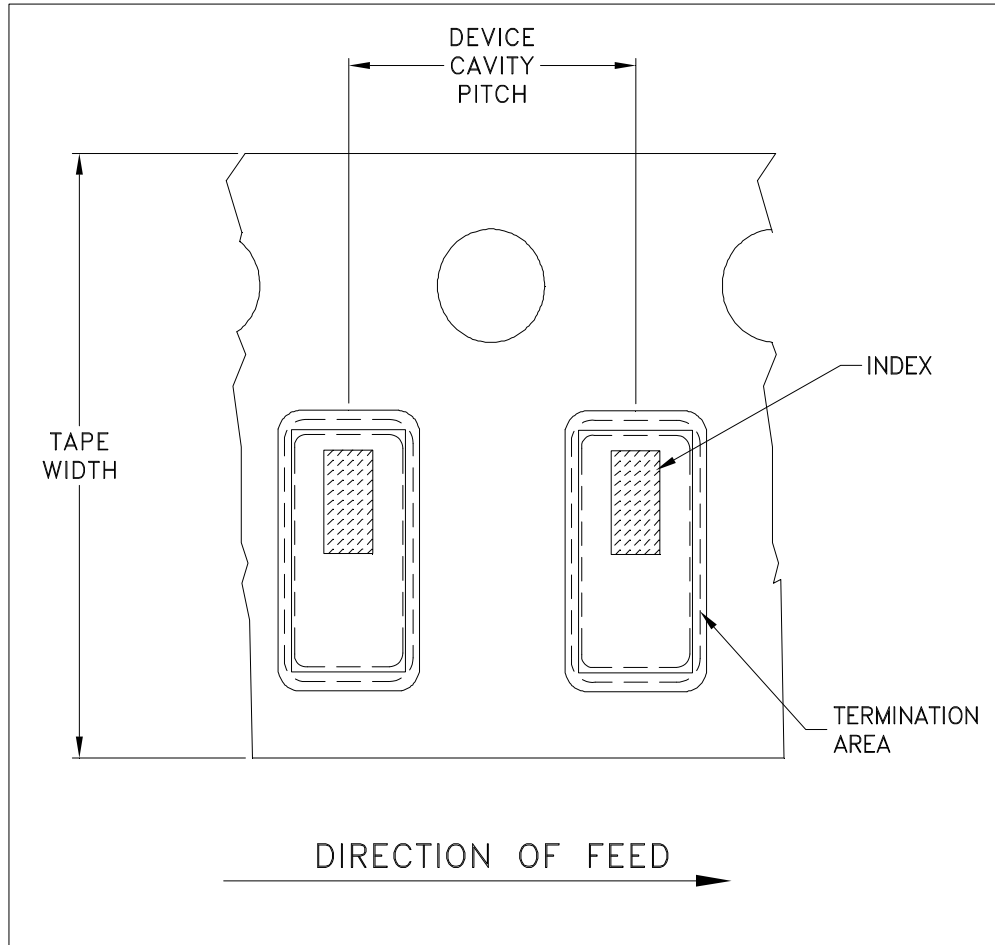

ILLUSTRATION 1

Tape Width, mm	Device Cavity Pitch, mm	Reel Size, inches	Devices per Reel	
8	4	7	Small quantity standards (see note)	20
				50
				100
				200
				500
				1000
			Standard	3000

Note: Please Consult individual model data sheet to determine device per reel availability.

Mini-Circuits carrier tape materials provide protection from ESD (Electro-Static Discharge) during handling and transportation. Tapes are static dissipative and comply with industry standards EIA-481/EIA-541.

Go to: www.minicircuits.com/pages/pdfs/tape.pdf



P.O. Box 350166, Brooklyn, New York 11235-0003 (718) 934-4500 Fax (718) 332-4661 For detailed performance specs & shopping online see Mini-Circuits web site



The Design Engineers Search Engine Provides ACTUAL Data Instantly From MINI-CIRCUITS At: www.minicircuits.com

RF/IF MICROWAVE COMPONENTS

THIRD ANGLE PROJECTION

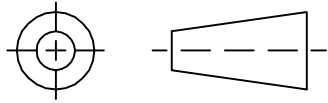

REVISIONS

REV	ECN No.	DESCRIPTION	DATE	DR	AUTH
OR	M88634	NEW RELEASE	08/28/03	GF	ABD
A	M102713	ADDED "...WITH SMOBC"	01/17/06	MMG	IL

SUGGESTED MOUNTING CONFIGURATION
FOR FV1206 CASE STYLE, "nx" PIN CONNECTION

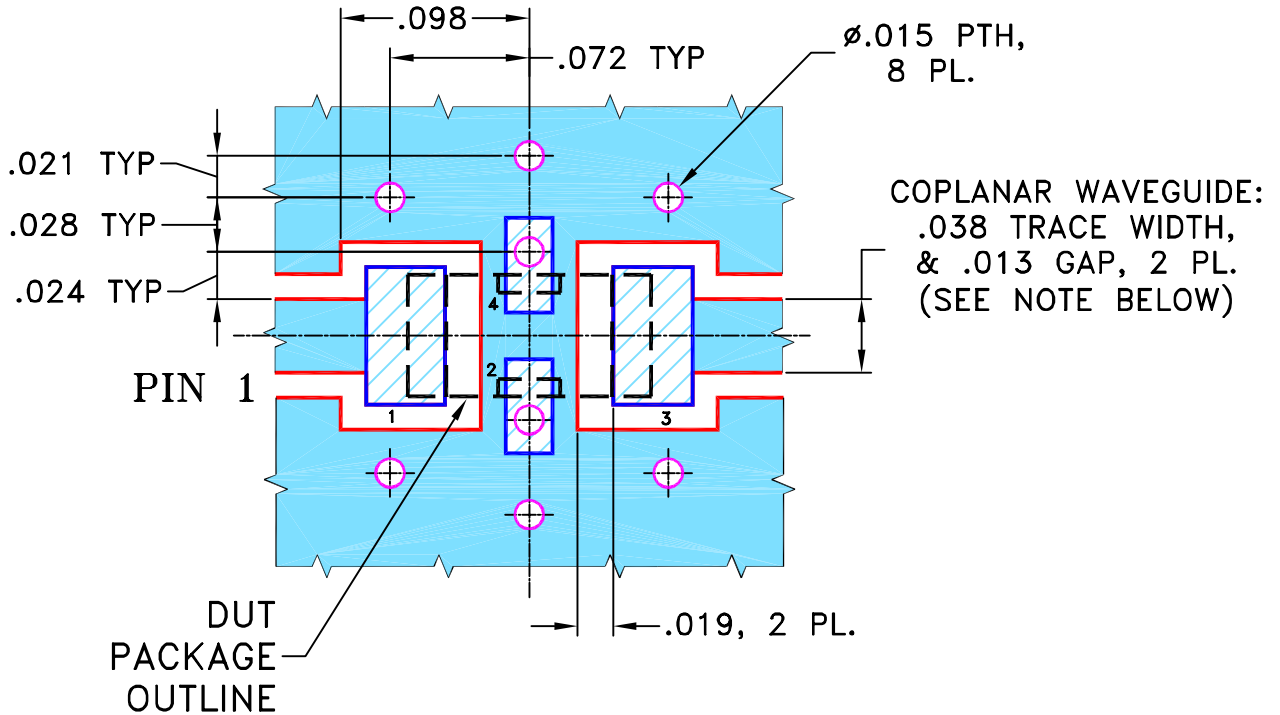

- NOTES:**
- COPLANAR WAVEGUIDE PARAMETERS ARE SHOWN FOR ROGERS R04350B WITH THICKNESS .020" ± .0015".
 COPPER: 1/2 OZ. EACH SIDE.
 FOR OTHER MATERIALS TRACE WIDTH & GAP MAY NEED TO BE MODIFIED.

2. BOTTOM SIDE OF THE PCB IS CONTINUOUS GROUND PLANE.



DENOTES PCB COPPER LAYOUT WITH SMOBC
 (SOLDER MASK OVER BARE COPPER)



DENOTES COPPER LAND PATTERN FREE OF SOLDER MASK

UNLESS OTHERWISE SPECIFIED

INITIALS

DATE

DIMENSIONS ARE IN INCHES

DRAWN

GF

08/27/03

TOLERANCES ON:

CHECKED

AV

08/28/03

2 PL DECIMALS ±

APPROVED

ABD

08/28/03

3 PL DECIMALS ± .005

ANGLES ±

FRACTIONS ±

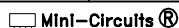

THIS DOCUMENT AND ITS CONTENTS ARE THE PROPERTY OF MINI-CIRCUITS. EXCEPT FOR USE EXPRESSLY GRANTED, IN WRITING, TO ITS VENDORS, VENDEE AND THE UNITED STATES GOVERNMENT, MINI-CIRCUITS RESERVES ALL PROPRIETARY DESIGN, USE, MANUFACTURING AND REPRODUCTION RIGHTS THERETO. THESE CONTENTS SHALL NOT BE USED, DUPLICATED OR DISCLOSED TO ANY OUTSIDE PARTY, IN WHOLE OR IN PART, WITHOUT WRITTEN PERMISSION OF MINI-CIRCUITS.

ASHEETA1.DWG REV:A DATE:01/12/95



Mini-Circuits®

13 Neptune Avenue
 Brooklyn NY 11235

PL, nx, FV1206, LFCN/HFCN, TB-270

SIZE

CODE IDENT

DRAWING NO:

REV:

A

15542

98-PL-137

A

FILE: 98PL137

SCALE:

10:1

SHEET:

1 OF 1

Evaluation Board and Circuit

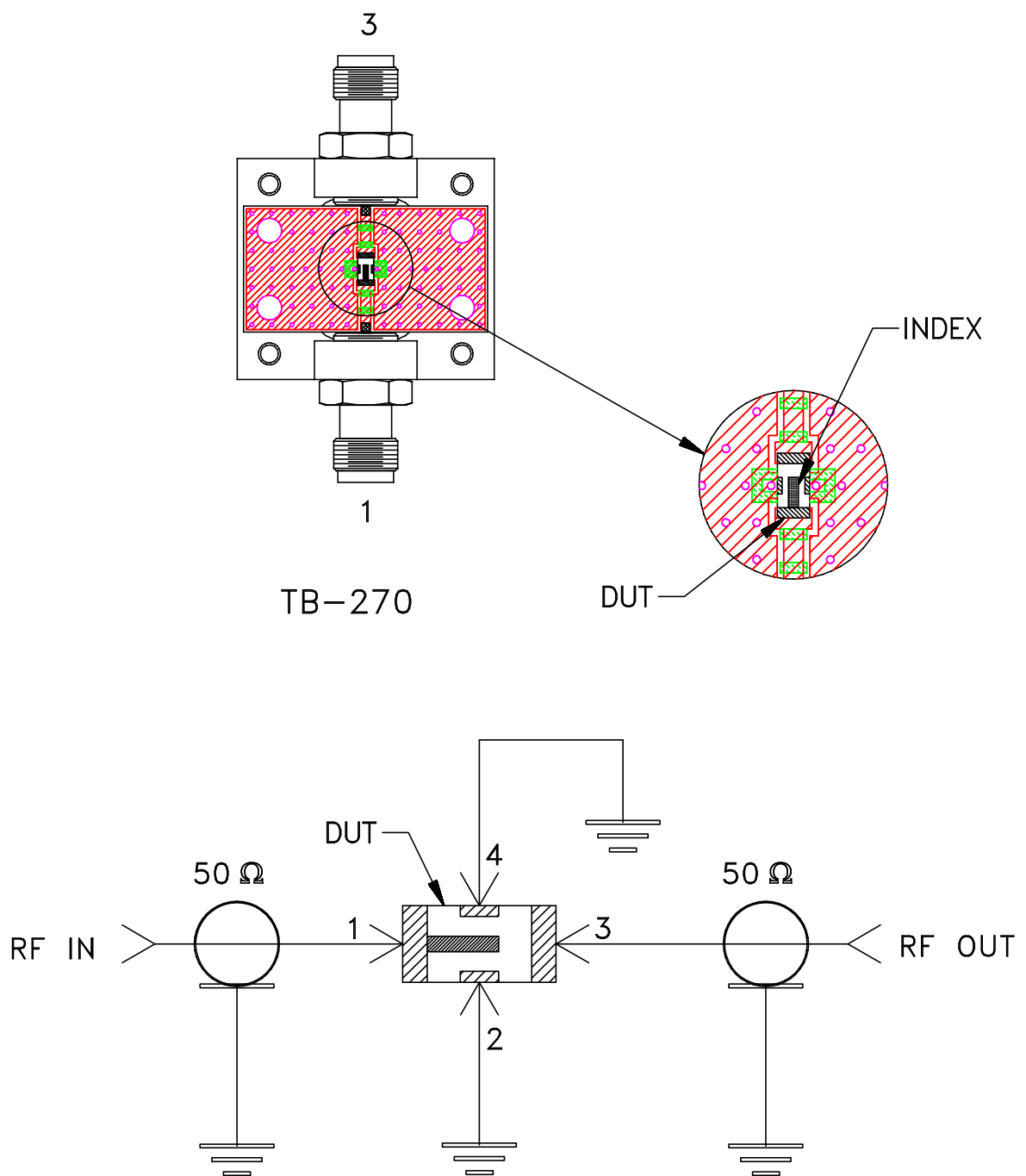

Schematic Diagram

Notes:

1. SMA Female connectors.
2. PCB Material: ROGERS R04350 or equivalent, Dielectric Constant=3.5, Thickness=.020 inch.

 **Mini-Circuits®**

All Mini-Circuits products are manufactured under exacting quality assurance and control standards, and are capable of meeting published specifications after being subjected to any or all of the following physical and environmental test.

Specification	Test/Inspection Condition	Reference/Spec
Operating Temperature	-55° to 100°C Ambient Environment	Individual Model Data Sheet
Storage Temperature	-55° to 100° C Ambient Environment	Individual Model Data Sheet
Humidity	90 to 95% RH, 240 hours, 50°C	MIL-STD-202, Method 103, Condition A, Except 50°C and end-point electrical test done within 12 hours
Solder Reflow Heat	Sn-Pb Eutetic Process: 225°C peak Pb-Free Process 245° - 250°C peak	J-STD-020, Table 4-1, 4-2 and 5-2, Figure 5-1
Solderability	10X Magnification	J-STD-002, Para 4.2.5, Test S, 95% Coverage
Vibration (High Frequency)	20g peak, 10-2000 Hz, 12 times in each of three perpendicular directions (total 36)	MIL-STD-202, Method 204, Condition D
Mechanical Shock	50g, 11 ms, 1/2-sine, 18 shocks: 3 each direction, each of 3 axes	MIL-STD-202, Method 213, Condition A