



LTCC SMT

# Band Pass Filter

## BFCN-2840+

Mini-Circuits

50Ω 2750 to 2930 MHz

### THE BIG DEAL

- Good Rejection, 25 dB Typ.
- 1206 Surface Mount Footprint
- Power Handling: 1.5 Watts

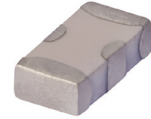

Generic photo used for illustration purposes only

CASE STYLE: FV1206

### +RoHS Compliant

The +Suffix identifies RoHS Compliance.  
See our website for methodologies and qualifications

### APPLICATIONS

- Harmonic Rejection
- Transmitters / Receivers
- WiMAX

### PRODUCT OVERVIEW

Mini-Circuits' BFCN-2840+ LTCC Band Pass Filter is constructed with multiple layers in order to achieve a miniature size and high repeatability of performance. Wrap-around terminations minimize variations in performance due to parasitics. Covering 180 MHz passband, these units offer low insertion loss and good rejection.

### KEY FEATURES

Feature	Advantages
Small Size, 1206	Allows for high layout density of circuit boards, while minimizing the effects of parasitics
Wrap around termination	Provides excellent solderability and easy visual inspection capability.
LTCC construction	Provides a rugged package that is well suited for tough environments including high humidity and high temperature extremes.
Rugged Power handling	Handles up to 1.5 Watts in a small package.

REV. B  
ECO-016659  
BFCN-2840+  
URJ  
230202





### ELECTRICAL SPECIFICATIONS<sup>1,2</sup> AT 25°C

Parameter	F#	Frequency (MHz)	Min.	Typ.	Max.	Units
Passband	Center Frequency	—	—	2840	—	MHz
	Insertion Loss	F1-F2	2750 - 2930	—	7	dB
	Return Loss	F1-F2	2750 - 2930	6.0	12.7	dB
Stop Band, Lower	Rejection	DC-F3	DC - 1500	—	25	dB
		DC-F4	DC - 1550	20	—	dB
Stop Band, Upper	Rejection	F5-F6	4000 - 4050	20	—	dB
		F6-F7	4050 - 6000	—	25	dB

1. This component should not be used as a DC-block. In applications where DC voltage and/or current is present at either the input or output ports, external DC blocking capacitors are required.

2. Measured on Mini-Circuits Characterization Test Board TB-270.

### ABSOLUTE MAXIMUM RATINGS<sup>1</sup>

Parameter	Ratings
Operating temperature	-55°C to 100°C
Storage temperature	-55°C to 100°C
RF Power Input <sup>2</sup>	1.5W @25°C

- Permanent damage may occur if any of these limits are exceeded.
- Power rating applies only to signals within the passband. Power rating above +25°C operating temperature decreases linearly to 0.25W at +100°C.

### TYPICAL FREQUENCY RESPONSE

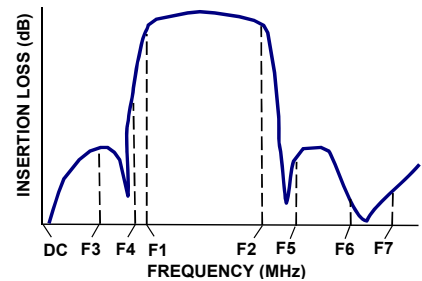

### FUNCTIONAL DIAGRAM

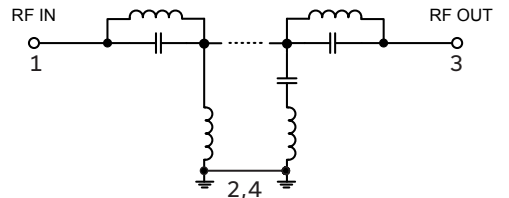



### PAD CONNECTIONS

RF IN	1
RF OUT	3
GROUND	2,4

PRODUCT MARKING: RY

DEMO BOARD MCL P/N: TB-270  
SUGGESTED PCB LAYOUT (PL-137)

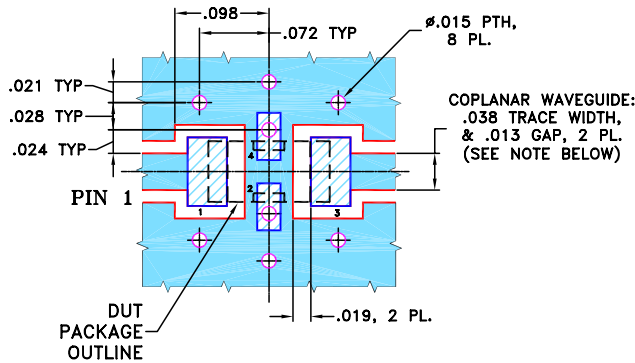

- NOTES:**
- COPLANAR WAVEGUIDE PARAMETERS ARE SHOWN FOR ROGERS R04350B WITH THICKNESS .020" ± .0015".  
COPPER: 1/2 OZ. EACH SIDE.  
FOR OTHER MATERIALS TRACE WIDTH & GAP MAY NEED TO BE MODIFIED.
  - BOTTOM SIDE OF THE PCB IS CONTINUOUS GROUND PLANE.
- DENOTES PCB COPPER LAYOUT WITH SMOBC (SOLDER MASK OVER BARE COPPER)
  - DENOTES COPPER LAND PATTERN FREE OF SOLDER MASK

### OUTLINE DRAWING

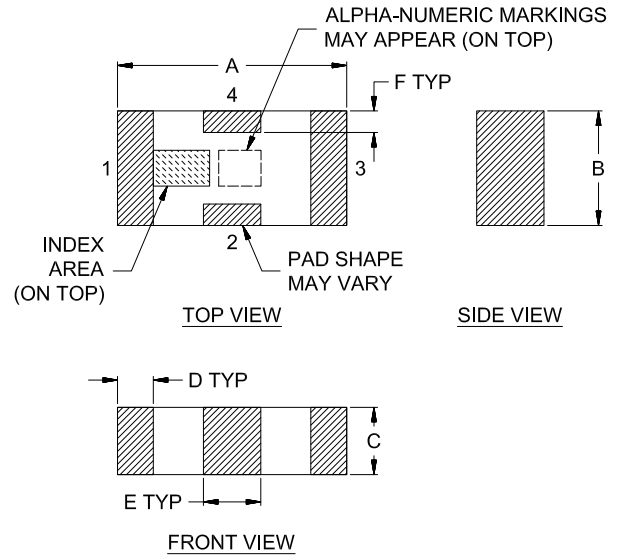

### OUTLINE DIMENSIONS (Inches/mm)

A	B	C	D	E	F	Wt.
.126	.063	.037	.020	.032	.009	grams
3.20	1.60	0.94	0.51	0.81	0.23	.020



LTCC SMT

# Band Pass Filter

## BFCN-2840+

### TYPICAL PERFORMANCE DATA AT 25°C

Frequency (MHz)	Insertion Loss (dB)	Return Loss (dB)
50	84.00	0.13
1025	32.99	0.30
1500	25.57	0.38
1550	24.89	0.40
2666	3.41	10.65
2750	2.30	16.08
2795	2.14	17.59
2840	2.12	18.74
2903	2.29	21.98
2930	2.47	25.66
3037	5.58	9.88
3144	19.86	3.42
3679	30.28	1.01
4000	24.80	0.74
4050	27.06	0.68
6000	33.85	0.81

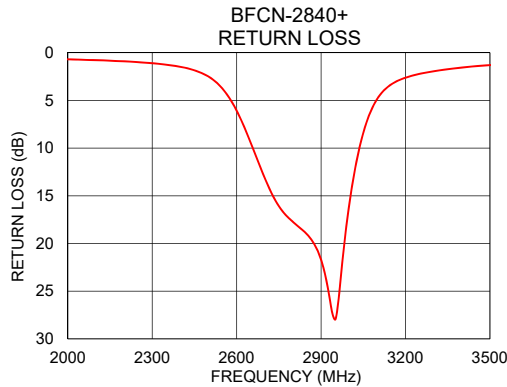
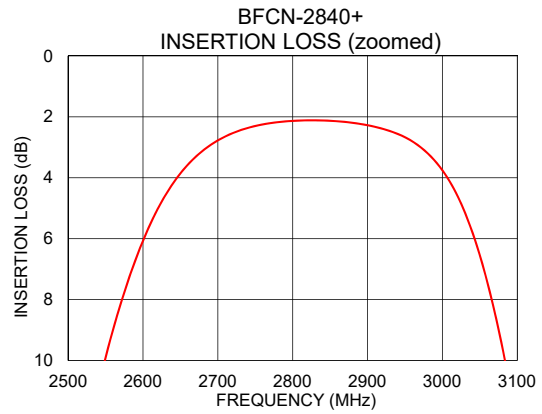
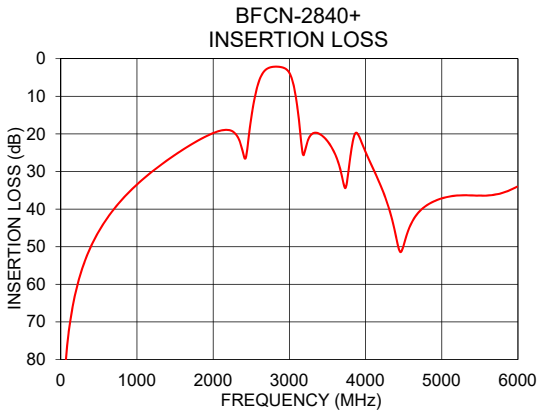

- NOTES**
- A. Performance and quality attributes and conditions not expressly stated in this specification document are intended to be excluded and do not form a part of this specification document.
  - B. Electrical specifications and performance data contained in this specification document are based on Mini-Circuit's applicable established test performance criteria and measurement instructions.
  - C. The parts covered by this specification document are subject to Mini-Circuits standard limited warranty and terms and conditions (collectively, "Standard Terms"); Purchasers of this part are entitled to the rights and benefits contained therein. For a full statement of the standard. Terms and the exclusive rights and remedies thereunder, please visit Mini-Circuits' website at [www.minicircuits.com/MCLStore/terms.jsp](http://www.minicircuits.com/MCLStore/terms.jsp)



# Ceramic Band Pass Filter

# BFCN-2840+

## Typical Performance Data

FREQ. (MHz)	INSERTION LOSS (dB)	INPUT RETURN LOSS (dB)	OUTPUT RETURN LOSS (dB)
	@ +25° C	@ +25° C	@ +25° C
50	84.86	0.07	0.00
60	81.54	0.08	0.00
70	78.85	0.08	0.00
80	76.60	0.09	0.01
90	75.10	0.10	0.01
100	73.09	0.10	0.01
200	61.16	0.15	0.02
300	54.23	0.17	0.04
400	49.24	0.20	0.06
500	45.37	0.21	0.08
600	42.16	0.23	0.11
700	39.45	0.24	0.14
800	37.08	0.26	0.17
900	35.02	0.27	0.20
1000	33.17	0.28	0.23
1100	31.46	0.29	0.26
1200	29.87	0.30	0.29
1300	28.33	0.31	0.31
1400	26.92	0.32	0.33
1500	25.64	0.33	0.35
1550	25.02	0.34	0.36
1600	24.37	0.35	0.36
1700	23.16	0.37	0.37
1800	22.05	0.40	0.39
1900	21.09	0.45	0.42
2000	20.26	0.51	0.45
2100	19.56	0.59	0.51
2200	19.25	0.69	0.59
2300	20.04	0.85	0.74
2400	24.55	1.12	1.01
2500	20.08	1.84	1.73
2570	10.64	3.35	3.18
2650	4.83	7.76	7.12
2800	2.32	16.38	13.05
2840	2.26	14.49	11.90
2900	2.55	11.44	9.42
2930	2.71	10.24	8.12
3070	8.96	6.48	2.72
3130	16.52	4.85	1.48
3190	20.25	3.51	1.08
3200	18.93	3.33	1.05
3300	14.43	2.22	0.94
3400	14.34	1.69	0.86
3500	15.47	1.40	0.82
3600	17.23	1.22	0.82
3700	19.29	1.11	0.91
3800	21.52	1.03	1.30
3900	24.97	0.97	3.91
4000	28.82	0.92	7.02
4500	36.06	0.79	0.65
5000	33.47	0.69	0.58
5500	30.78	0.69	0.66
6000	29.75	0.75	0.77

REV. X1  
BFCN-2840+  
090921  
Page 1 of 1



IF/RF MICROWAVE COMPONENTS • ISO 9001 ISO 14001 AS9100 CERTIFIED • RoHS compliant  
P.O. Box 350166, Brooklyn, New York 11235-0003 (718) 934-4500 Fax (718) 332-4661



The Design Engineers Search Engine finds the model you need, Instantly • For detailed performance specs & shopping online see



## Typical Performance Curves

### INSERTION LOSS vs. TEMPERATURE

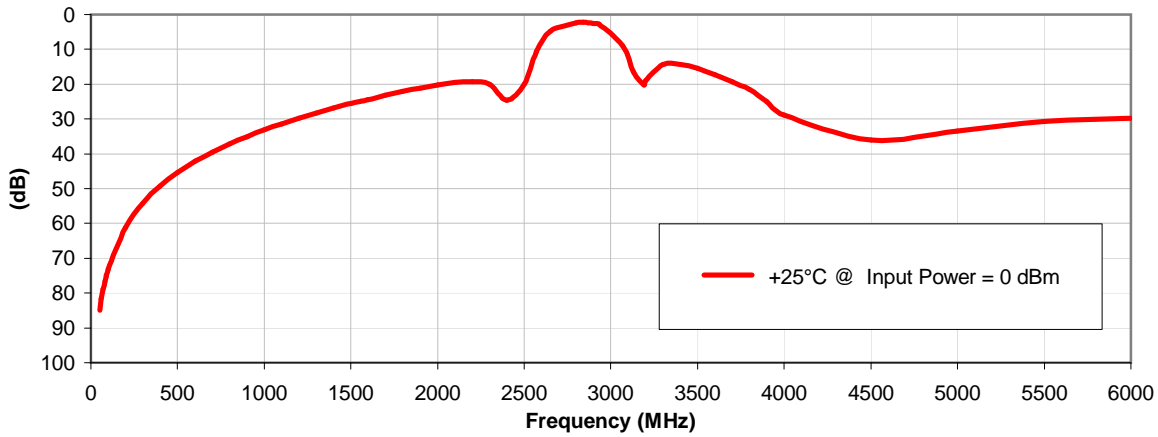

### INPUT RETURN LOSS vs. TEMPERATURE

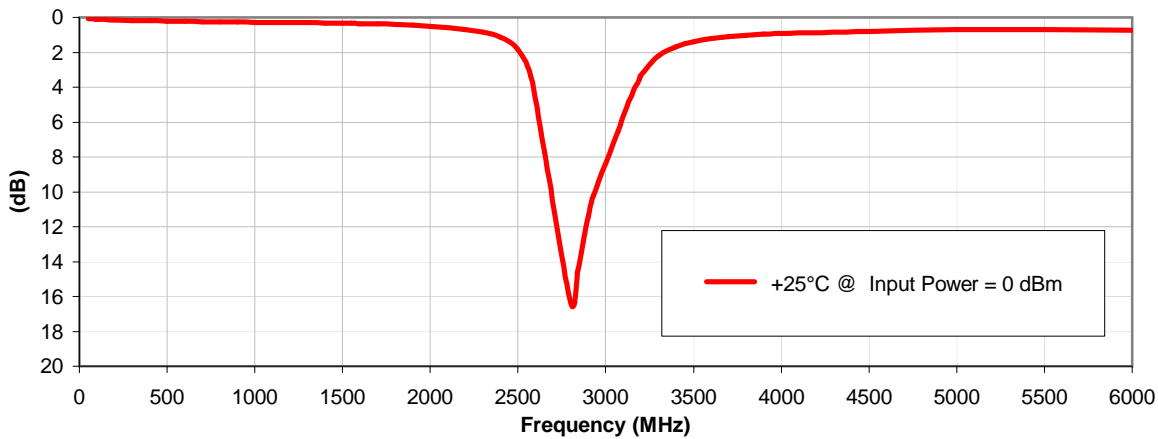

### OUTPUT RETURN LOSS vs. TEMPERATURE

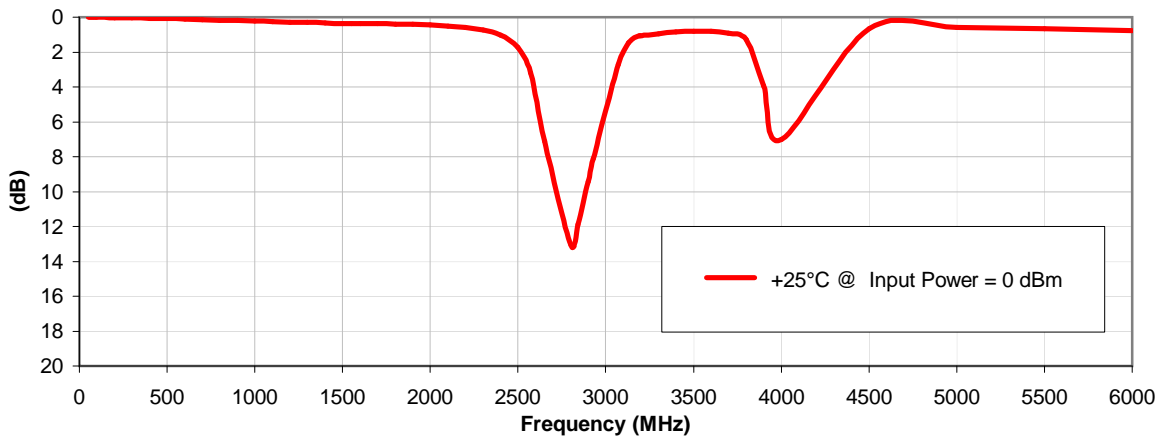

### Outline Dimensions

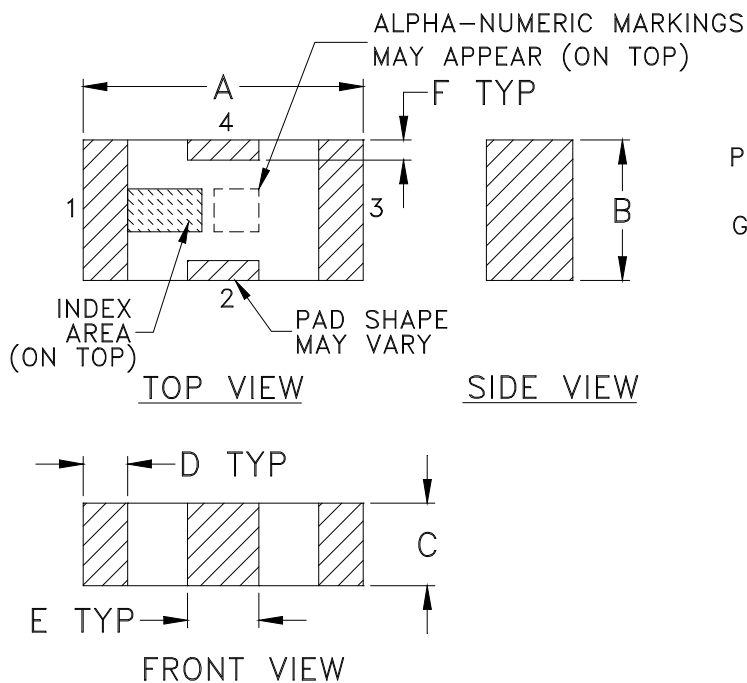

### PCB Land Pattern

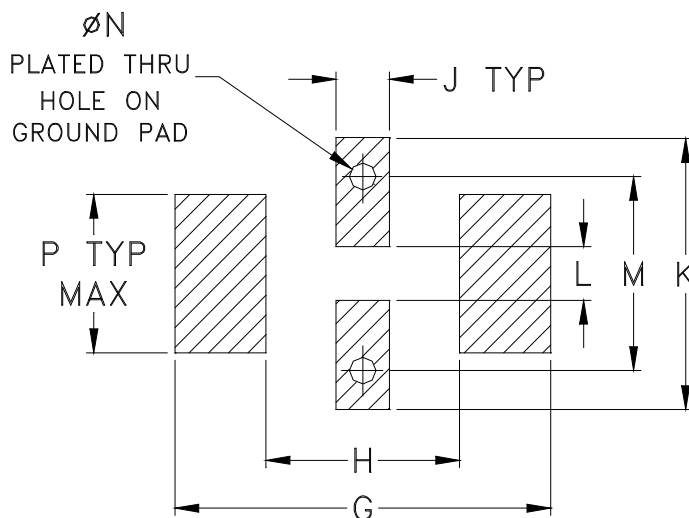

Suggested Layout,  
Tolerance to be within  $\pm .002$

CASE #	A	B	C	D	E	F	G	H	J	K	L	M	N	P	WT. GRAM
FV1206	.126 (3.20)	.063 (1.60)	.037 (0.94)	.020 (0.51)	.032 (0.81)	.009 (0.23)	.169 (4.29)	.087 (2.21)	.024 (0.61)	.122 (3.10)	.024 (0.61)	.087 (2.21)	.012 (0.30)	.071 (1.80)	.020

Dimensions are in inches (mm). Tolerances: 2 Pl.  $\pm .01$ ; 3 Pl.  $\pm .005$

#### Notes:

- Open style, ceramic base.
- Termination finish: **as shown below or indicated on Data Sheet.**  
 For RoHS Case Styles: Tin plate over Nickel plate. All models, (+) suffix.  
 For RoHS-5 Case Styles: Tin-Lead plate. All models, no (+) suffix.



P.O. Box 350166, Brooklyn, New York 11235-0003 (718) 934-4500 Fax (718) 332-4661 For detailed performance specs & shopping online see Mini-Circuits web site



The Design Engineers Search Engine Provides ACTUAL Data Instantly From MINI-CIRCUITS At: [www.minicircuits.com](http://www.minicircuits.com)

RF/IF MICROWAVE COMPONENTS

# Tape & Reel Packaging TR-F71

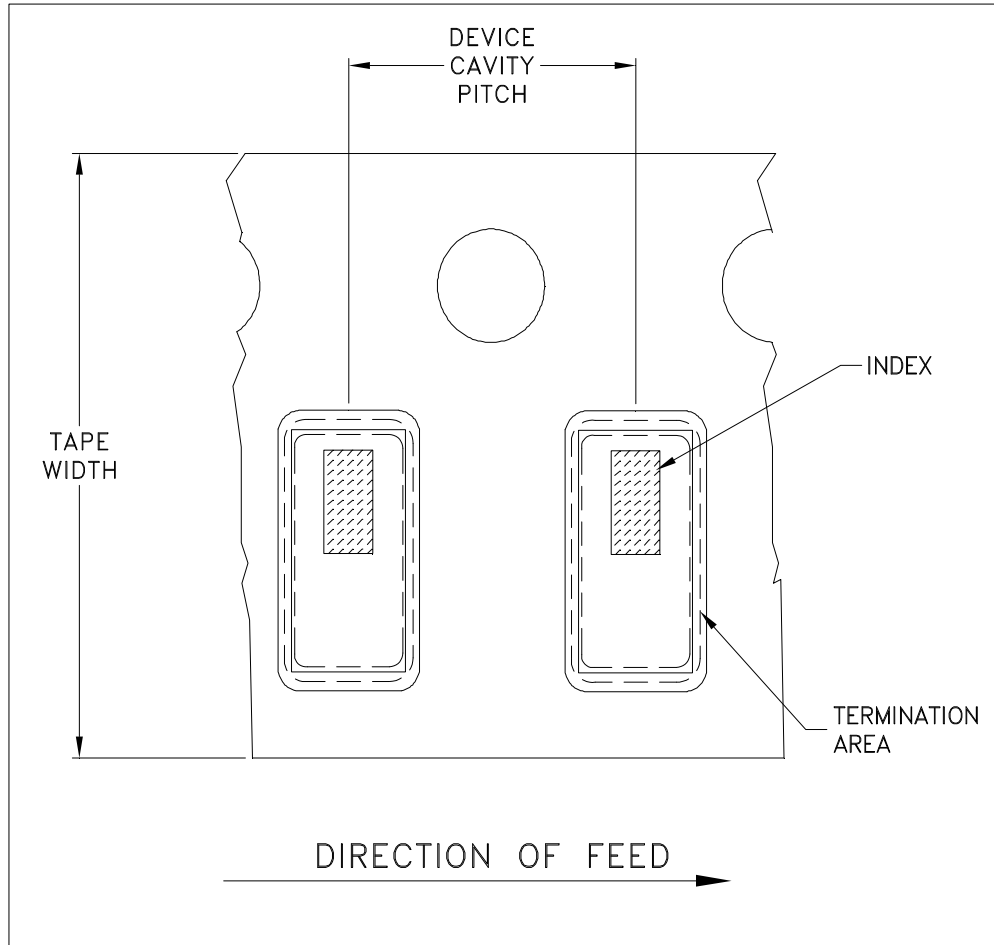

ILLUSTRATION 1

Tape Width, mm	Device Cavity Pitch, mm	Reel Size, inches	Devices per Reel	
8	4	7	Small quantity standards (see note)	20
				50
				100
				200
				500
				1000
			Standard	3000

Note: Please Consult individual model data sheet to determine device per reel availability.

Mini-Circuits carrier tape materials provide protection from ESD (Electro-Static Discharge) during handling and transportation. Tapes are static dissipative and comply with industry standards EIA-481/EIA-541.

Go to: [www.minicircuits.com/pages/pdfs/tape.pdf](http://www.minicircuits.com/pages/pdfs/tape.pdf)



P.O. Box 350166, Brooklyn, New York 11235-0003 (718) 934-4500 Fax (718) 332-4661 For detailed performance specs & shopping online see Mini-Circuits web site



The Design Engineers Search Engine Provides ACTUAL Data Instantly From MINI-CIRCUITS At: [www.minicircuits.com](http://www.minicircuits.com)

RF/IF MICROWAVE COMPONENTS



THIRD ANGLE PROJECTION

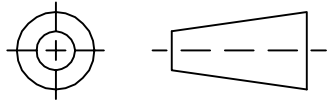

REVISIONS

REV	ECN No.	DESCRIPTION	DATE	DR	AUTH
OR	M88634	NEW RELEASE	08/28/03	GF	ABD
A	M102713	ADDED "...WITH SMOBC"	01/17/06	MMG	IL

SUGGESTED MOUNTING CONFIGURATION  
FOR FV1206 CASE STYLE, "nx" PIN CONNECTION

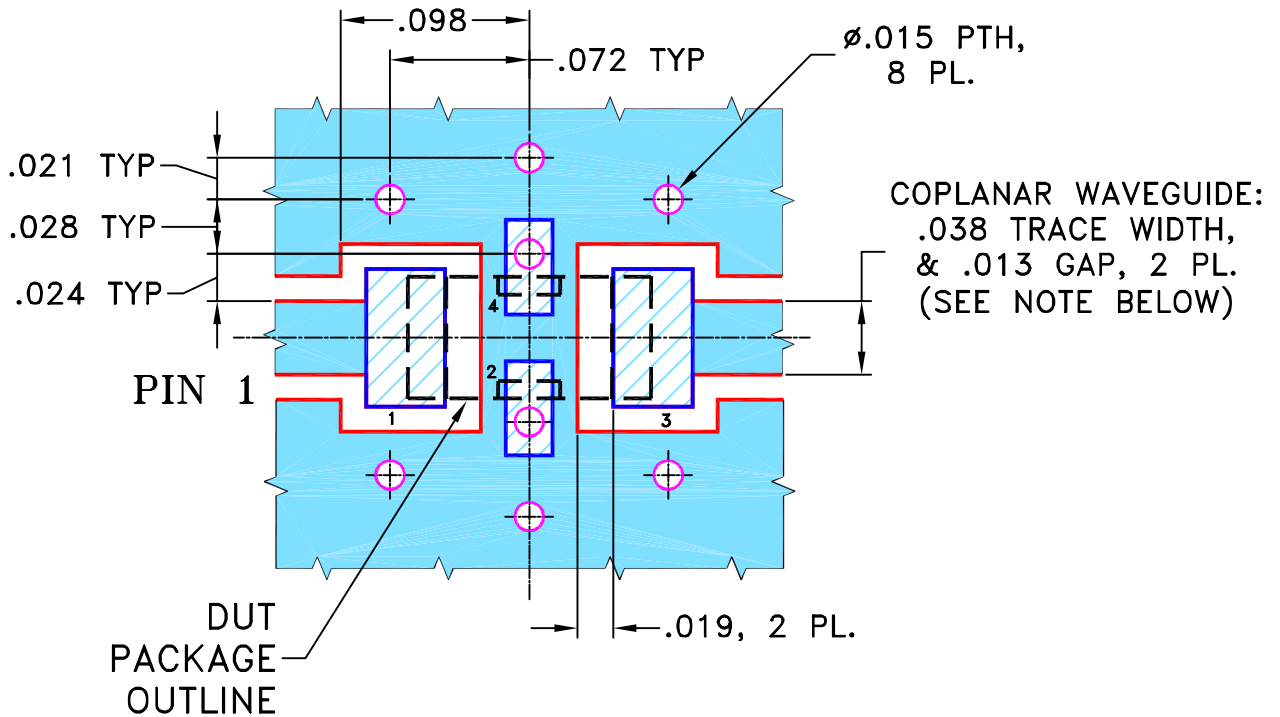

- NOTES:**
1. COPLANAR WAVEGUIDE PARAMETERS ARE SHOWN FOR ROGERS R04350B WITH THICKNESS .020" ± .0015".  
 COPPER: 1/2 OZ. EACH SIDE.  
 FOR OTHER MATERIALS TRACE WIDTH & GAP MAY NEED TO BE MODIFIED.

2. BOTTOM SIDE OF THE PCB IS CONTINUOUS GROUND PLANE.



DENOTES PCB COPPER LAYOUT WITH SMOBC  
 (SOLDER MASK OVER BARE COPPER)



DENOTES COPPER LAND PATTERN FREE OF SOLDER MASK

UNLESS OTHERWISE SPECIFIED	INITIALS	DATE
DIMENSIONS ARE IN INCHES TOLERANCES ON: 2 PL DECIMALS ± 3 PL DECIMALS ± .005 ANGLES ± FRACTIONS ±	DRAWN	GF 08/27/03
	CHECKED	AV 08/28/03
	APPROVED	ABD 08/28/03



**Mini-Circuits®**

13 Neptune Avenue  
 Brooklyn NY 11235

PL, nx, FV1206, LFCN/HFCN, TB-270

SIZE A	CODE IDENT 15542	DRAWING NO: 98-PL-137	REV: A
FILE:	98PL137	SCALE: 10:1	SHEET: 1 OF 1

Mini-Circuits®  
 THIS DOCUMENT AND ITS CONTENTS ARE THE PROPERTY OF MINI-CIRCUITS.  
 EXCEPT FOR USE EXPRESSLY GRANTED, IN WRITING, TO ITS VENDORS, VENDEE  
 AND THE UNITED STATES GOVERNMENT, MINI-CIRCUITS RESERVES ALL PROPRIETARY  
 DESIGN, USE, MANUFACTURING AND REPRODUCTION RIGHTS THERETO.  
 THESE CONTENTS SHALL NOT BE USED, DUPLICATED OR DISCLOSED TO ANY OUTSIDE  
 PARTY, IN WHOLE OR IN PART, WITHOUT WRITTEN PERMISSION OF MINI-CIRCUITS.

# Evaluation Board and Circuit

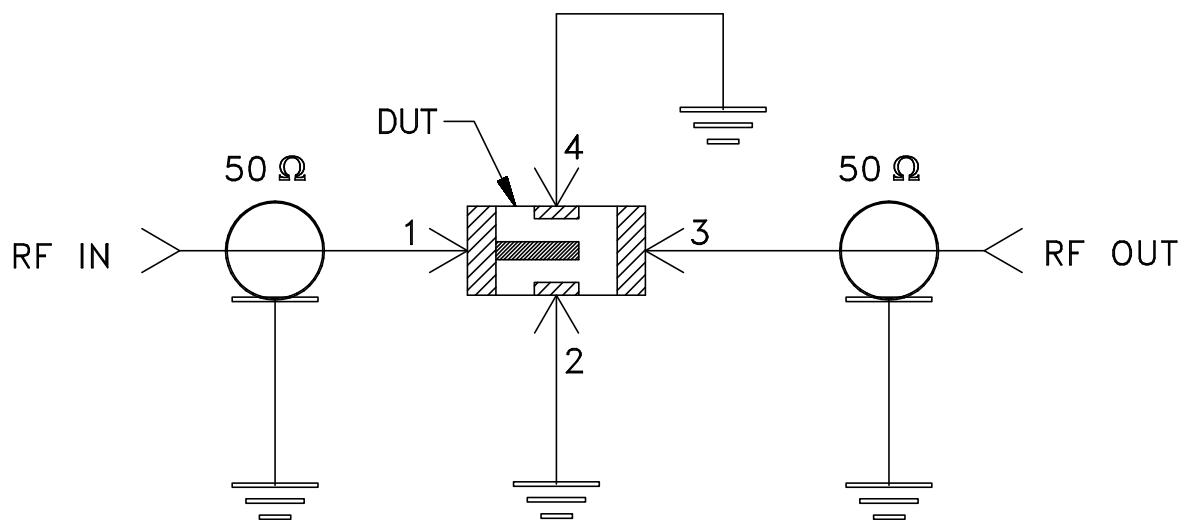
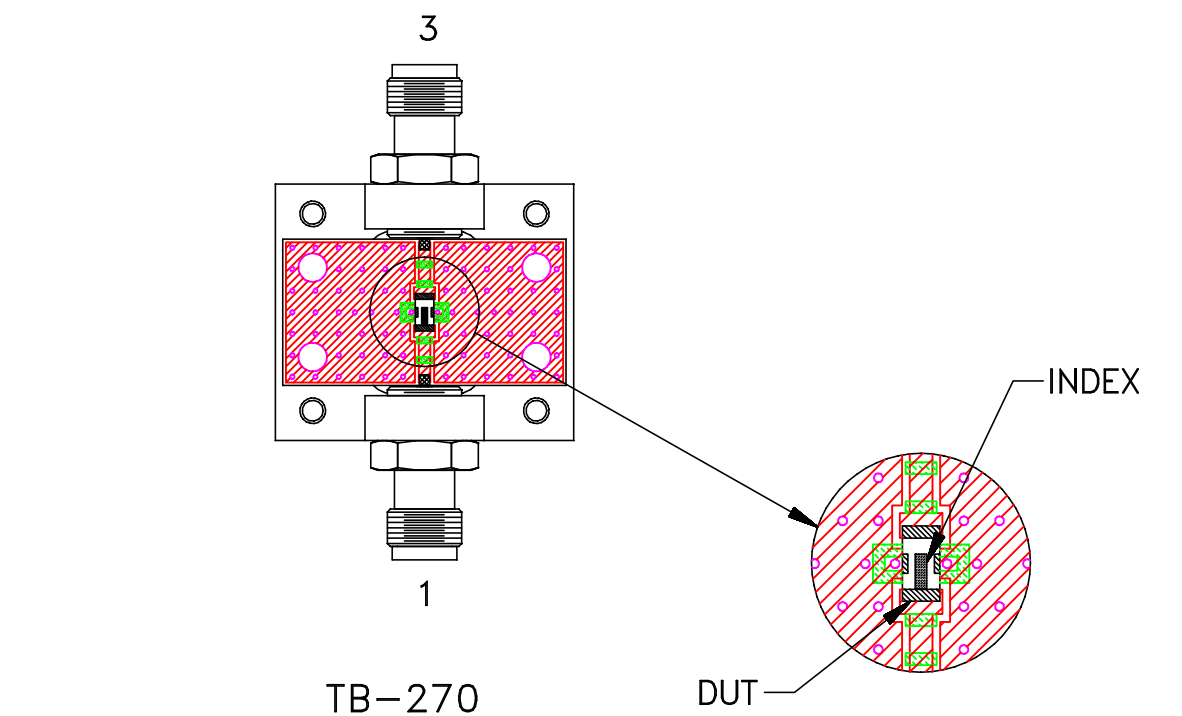

Schematic Diagram

## Notes:

1. SMA Female connectors.
2. PCB Material: ROGERS R04350 or equivalent, Dielectric Constant=3.5, Thickness=.020 inch.

 **Mini-Circuits®**

All Mini-Circuits products are manufactured under exacting quality assurance and control standards, and are capable of meeting published specifications after being subjected to any or all of the following physical and environmental test.

Specification	Test/Inspection Condition	Reference/Spec
Operating Temperature	-55° to 100°C Ambient Environment	Individual Model Data Sheet
Storage Temperature	-55° to 100° C Ambient Environment	Individual Model Data Sheet
Humidity	90 to 95% RH, 240 hours, 50°C	MIL-STD-202, Method 103, Condition A, Except 50°C and end-point electrical test done within 12 hours
Solder Reflow Heat	Sn-Pb Eutetic Process: 225°C peak Pb-Free Process 245° - 250°C peak	J-STD-020, Table 4-1, 4-2 and 5-2, Figure 5-1
Solderability	10X Magnification	J-STD-002, Para 4.2.5, Test S, 95% Coverage
Vibration (High Frequency)	20g peak, 10-2000 Hz, 12 times in each of three perpendicular directions (total 36)	MIL-STD-202, Method 204, Condition D
Mechanical Shock	50g, 11 ms, 1/2-sine, 18 shocks: 3 each direction, each of 3 axes	MIL-STD-202, Method 213, Condition A