

Ceramic Bandpass Filter

BFCG-252+

50Ω 2400 to 2500 MHz

The Big Deal

- Rugged, ceramic construction
- Tiny size, 0.079" x 0.049" x 0.037" (0805)
- Good power handling



CASE STYLE: GE0805C-3

Product Overview

Mini-Circuits' BFCG-252+ is a LTCC band pass filter with a passband from 2400 to 2500 MHz, supporting a variety of applications. This model provides 1.7 dB typical passband insertion loss and provides a very good stopband rejection due to strategically constructed layout with minimal interaction between components. It provides a wide operating temperature range from -55 to +125°C. Housed in a tiny 0805 ceramic form factor with wrap-around terminations, the filter is ideal for dense PCB layouts and with minimal performance variation due to parasitics.

Key Features

Feature	Advantages
Ultra-wide stopband	The LTCC band pass filter provides a very good stopband rejection suitable for high end applications.
LTCC Construction	Provides repeatable performance in a rugged, ceramic package well suited for tough environments such as high humidity and temperature extremes.
Tiny size (0.079 x 0.049 x 0.037")	Saves space in dense circuit board layouts and minimizes the effects of parasitics.
Good power handling	Supports a wide range of system power requirements.
Wrap-around terminations	Provides excellent solderability and easy visual inspection

Notes

- A. Performance and quality attributes and conditions not expressly stated in this specification document are intended to be excluded and do not form a part of this specification document.
B. Electrical specifications and performance data contained in this specification document are based on Mini-Circuit's applicable established test performance criteria and measurement instructions.
C. The parts covered by this specification document are subject to Mini-Circuits standard limited warranty and terms and conditions (collectively, "Standard Terms"); Purchasers of this part are entitled to the rights and benefits contained therein. For a full statement of the Standard Terms and the exclusive rights and remedies thereunder, please visit Mini-Circuits' website at www.minicircuits.com/MCLStore/terms.jsp



Ceramic Bandpass Filter

50Ω 2400 to 2500 MHz

BFCG-252+



Generic photo used for illustration purposes only

CASE STYLE: GE0805C-3

Features

- Miniature size 0805 (0.079"[2.0mm] x 0.049"[1.25mm] x 0.037"[0.95mm])
- High rejection
- Low cost
- Aqueous washable

+RoHS Compliant

The +Suffix identifies RoHS Compliance. See our web site for RoHS Compliance methodologies and qualifications

Applications

- ISM Band
- WLAN
- Bluetooth
- Zigbee

Electrical Specifications^{1,2} at 25°C

Parameter	F#	Frequency (MHz)	Min.	Typ.	Max.	Unit	
Pass Band	Center Frequency	—	—	2450	—	dB	
	Insertion Loss	F1-F2	2400 - 2500	—	1.7	3.5	dB
	Return Loss	F1-F2	2400 - 2500	—	10	—	dB
Stop Band, Lower	Insertion Loss	DC-F3	10 - 1350	25	35	—	dB
Stop Band, Upper	Insertion Loss	F4-F5	3400 - 3800	23	27	—	—
	Insertion Loss	F5-F6	3800 - 7000	30	36	—	dB
	Insertion Loss	F6-F7	7000 - 8000	27	36	—	—

1. Tested on Evaluation Board TB-BFCG-252+

2. This Filter is not intended for use as DC Blocking circuits element. In Application where DC Voltage is present at either input or output ports, blocking capacitors are required at the corresponding RF ports.

Functional Schematic

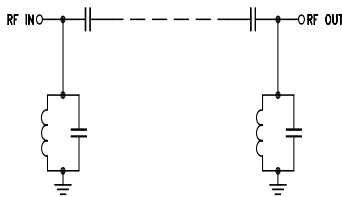

Maximum Ratings

Operating Temperature	-55°C to 125°C
Storage Temperature ³	-55°C to 125°C
RF Power Input ⁴	2W at 25°C

3. Refer to product storage temperature after installation.

Suggestion for T&R unused product storage condition +5 - +35°C. Humidity 45-75% RH, 12 month Max.

4. Derate linearly to 0.5W @ 125°C.

Permanent damage may occur if any of these limits exceeded.

Typical Frequency Response

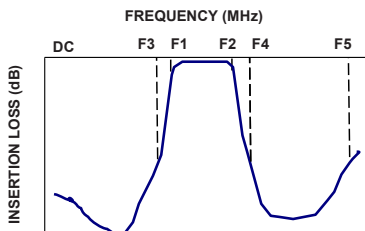

Typical Performance Data at 25°C

Frequency (MHz)	Insertion Loss (dB)	Return Loss (dB)
10	76.14	0.05
100	54.55	0.05
500	42.58	0.06
1000	51.94	0.09
1500	29.33	0.15
1860	17.55	0.34
2000	12.54	0.69
2400	1.40	15.05
2500	1.56	13.76
3000	20.55	0.30
4000	42.69	0.21
5000	42.04	0.39
6000	52.98	0.39
7000	46.28	0.23
8000	33.64	0.29

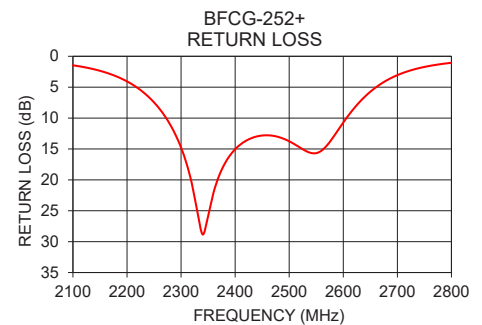
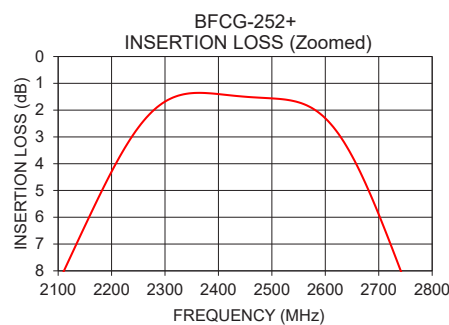
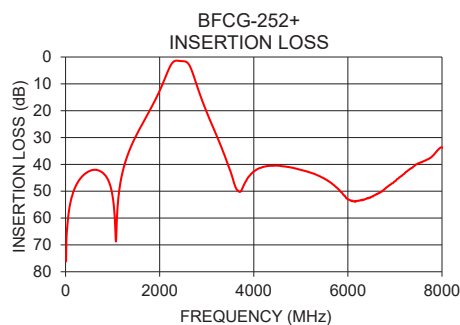

Notes

A. Performance and quality attributes and conditions not expressly stated in this specification document are intended to be excluded and do not form a part of this specification document.

B. Electrical specifications and performance data contained in this specification document are based on Mini-Circuit's applicable established test performance criteria and measurement instructions.

C. The parts covered by this specification document are subject to Mini-Circuits standard limited warranty and terms and conditions (collectively, "Standard Terms"); Purchasers of this part are entitled to the rights and benefits contained therein. For a full statement of the Standard Terms and the exclusive rights and remedies thereunder, please visit Mini-Circuits' website at www.minicircuits.com/MCLStore/terms.jsp



www.minicircuits.com P.O. Box 350166, Brooklyn, NY 11235-0003 (718) 934-4500 sales@minicircuits.com

REV. OR
ECO-004694
BFCG-252+
RS/CP/AM
201112
Page 2 of 3

Pad Connections

INPUT	1
OUTPUT	3
GROUND	2,4

Product Marking: N/A

Evaluation Board MCL P/N: TB-BFCG-252+ Suggested PCB Layout (PL-547)

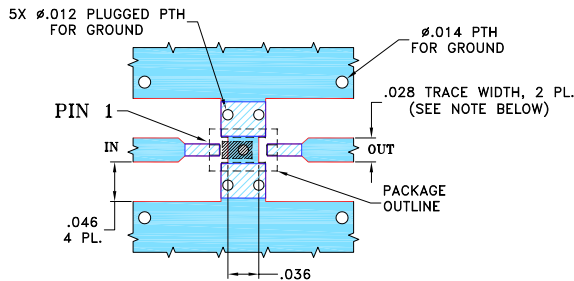

NOTES:

- TRACE WIDTH IS SHOWN FOR FR4, GRADE IT-180TC (ITEQ CORP.) WITH DIELECTRIC THICKNESS $.016 \pm .0015$. COPPER: 1/2 OZ., EACH SIDE. FOR OTHER MATERIALS TRACE WIDTH AND GAP MAY NEED TO BE MODIFIED.
- BOTTOM SIDE OF THE PCB IS CONTINUOUS GROUND PLANE.

- DENOTES PCB COPPER LAYOUT WITH SMOBC (SOLDER MASK OVER BARE COPPER).
- DENOTES COPPER LAND PATTERN FREE OF SOLDER MASK.

Outline Drawing

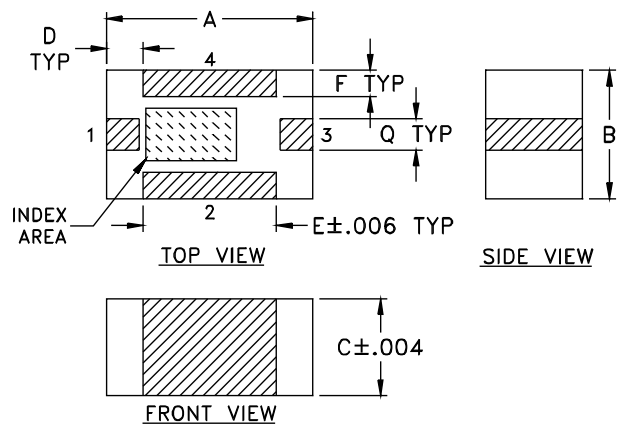

Outline Dimensions (inch/mm)

A	B	C	D	E	F	Q	wt
.079	.049	.037	.014	.051	.010	.012	grams
2.01	1.24	0.94	0.36	1.30	0.25	0.30	.020

Notes

- Performance and quality attributes and conditions not expressly stated in this specification document are intended to be excluded and do not form a part of this specification document.
- Electrical specifications and performance data contained in this specification document are based on Mini-Circuit's applicable established test performance criteria and measurement instructions.
- The parts covered by this specification document are subject to Mini-Circuits standard limited warranty and terms and conditions (collectively, "Standard Terms"); Purchasers of this part are entitled to the rights and benefits contained therein. For a full statement of the Standard Terms and the exclusive rights and remedies thereunder, please visit Mini-Circuits' website at www.minicircuits.com/MCLStore/terms.jsp

Typical Performance Data

FREQUENCY (MHz)	INSERTION LOSS (dB)	RETURN LOSS (dB)
10	76.14	0.05
50	60.58	0.05
100	54.55	0.05
200	48.68	0.05
300	45.57	0.05
400	43.68	0.06
500	42.58	0.06
600	42.02	0.07
700	42.23	0.07
800	43.25	0.07
900	45.61	0.08
1000	51.94	0.09
1100	57.33	0.10
1200	43.78	0.11
1350	35.13	0.12
1400	32.99	0.13
1500	29.33	0.15
1600	25.96	0.17
1700	22.77	0.21
1800	19.53	0.28
1900	16.19	0.41
2000	12.54	0.69
2100	8.46	1.46
2200	4.30	4.07
2300	1.68	14.79
2400	1.40	15.05
2410	1.42	14.26
2420	1.44	13.68
2430	1.47	13.26
2440	1.48	12.98
2450	1.50	12.83
2460	1.52	12.79
2470	1.53	12.87
2480	1.54	13.06
2490	1.55	13.36
2500	1.56	13.76
2600	2.31	10.72
2700	5.89	3.05
2800	11.10	1.06
2900	16.05	0.50
3000	20.55	0.30
3200	28.87	0.18
3400	37.65	0.16
3600	47.88	0.17
3800	47.36	0.18
4000	42.69	0.21
4200	40.96	0.24
4400	40.51	0.28
4600	40.66	0.32
4800	41.17	0.35
5000	42.04	0.39
5200	43.06	0.41
5400	44.41	0.42
5600	46.42	0.42
5800	49.29	0.41
6000	52.98	0.39
6200	53.60	0.35
6400	52.74	0.32
6600	51.16	0.28
6800	48.86	0.25
7000	46.28	0.23
7200	43.46	0.22
7400	40.75	0.23
7600	38.87	0.25
7800	36.87	0.31
8000	33.64	0.29

Typical Performance Curves

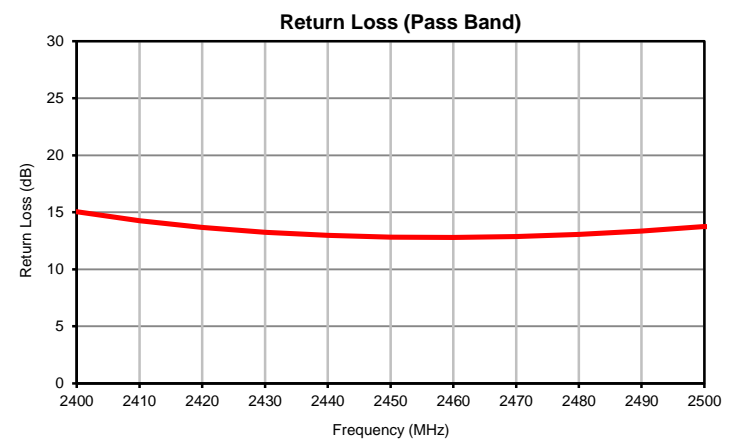
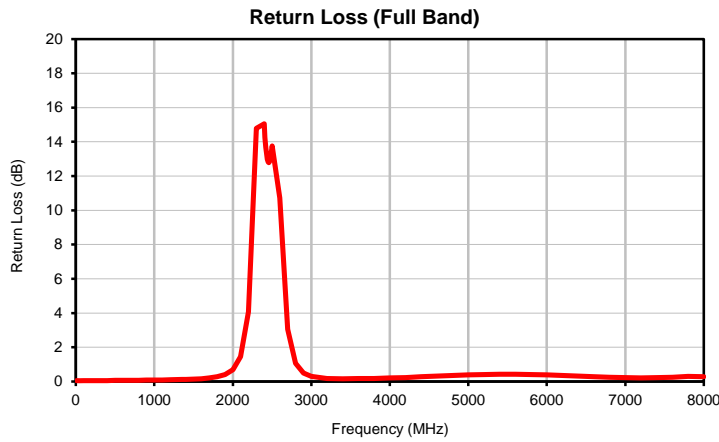
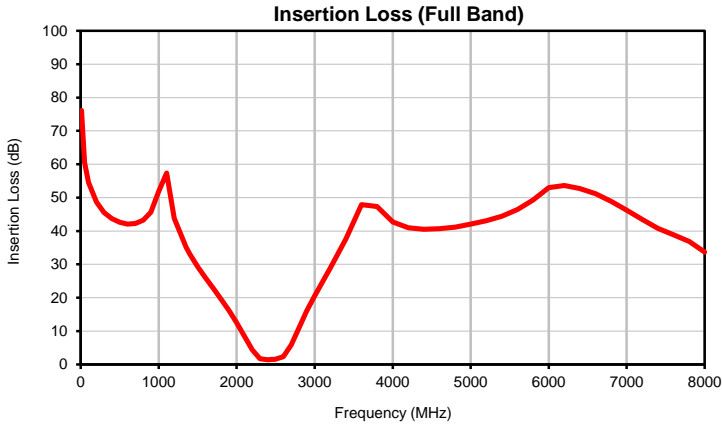

Outline Dimensions

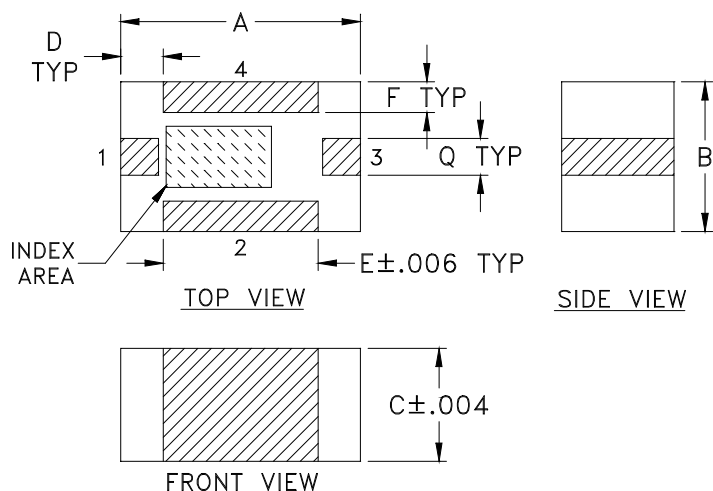

PCB Land Pattern

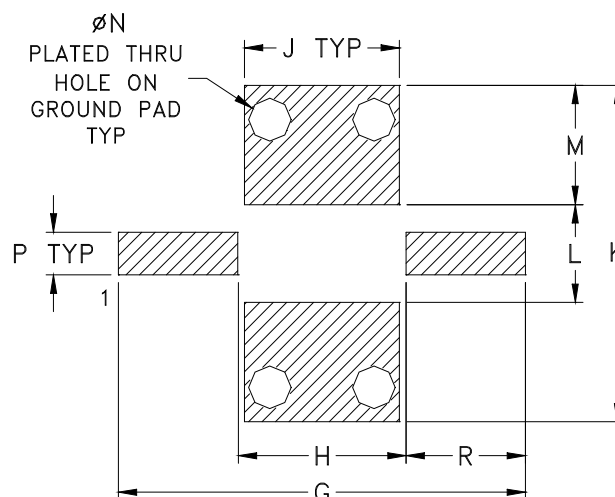

Suggested Layout,
Tolerance to be within $\pm .002$

CASE #	A	B	C	D	E	F	G	H	J	K	L
GE0805C-3	.079 (2.00)	.049 (1.25)	.037 (0.95)	.014 (0.35)	.051 (1.30)	.010 (0.25)	.134 (3.40)	.055 (1.40)	.051 (1.30)	.110 (2.80)	.032 (0.80)

CASE #	M	N	P	Q	R	WT. GRAM
GE0805C-3	.039 (1.00)	.014 (0.35)	.014 (0.35)	.012 (0.30)	.039 (1.00)	.020

Dimensions are in inches (mm). Tolerances: 2Pl. $\pm .01$; 3 Pl. $\pm .005$

Notes:

- Open style, ceramic base.
- Termination finish:
 - For RoHS Case Styles: Tin plate over Nickel plate. All models, (+) suffix.
 - For RoHS-5 Case Styles: Tin-Lead plate over Nickel plate. All models, no (+) suffix.



P.O. Box 350166, Brooklyn, New York 11235-0003 (718) 934-4500 Fax (718) 332-4661 For detailed performance specs & shopping online see Mini-Circuits web site



The Design Engineers Search Engine Provides ACTUAL Data Instantly From MINI-CIRCUITS At: www.minicircuits.com

RF/IF MICROWAVE COMPONENTS

Tape & Reel Packaging TR-F114

DEVICE ORIENTATION IN T&R



ILLUSTRATION 1

Applicable Case Styles	
GE0805C	JC0603C
GE0805C-1	JC0603C-4
GE0805C-1AP	JC0603C-6
GE0805C-7	
GE0805C-9	
GE0805C-10	
GE0805C-11	
GE0805C-12	

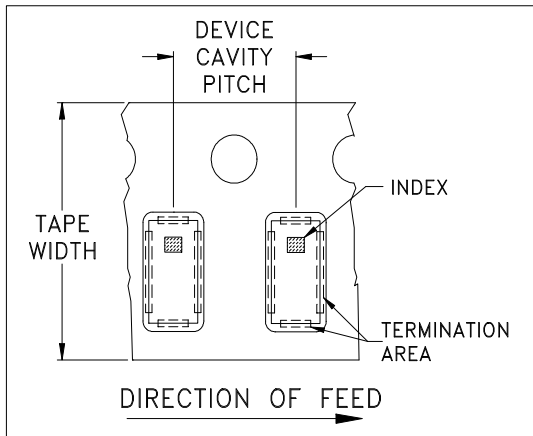

ILLUSTRATION 2

Applicable Case Styles	
GE0805C-2	JC0603C-1
GE0805C-3	JC0603C-2
GE0805C-4	JC0603C-3
GE0805C-5	JC0603C-5
GE0805C-6	JC0603C-7
GE0805C-8	JV1210C-1
GE0805C-15	

Tape Width, mm	Device Cavity Pitch, mm	Reel Size, inches	Devices per Reel	
8	4	7	Small quantity standards (see note)	20
				50
				100
				200
				500
				1000
			Standard	4000

Note: Please Consult individual model data sheet to determine device per reel availability.

Mini-Circuits carrier tape materials provide protection from ESD (Electro-Static Discharge) during handling and transportation. Tapes are static dissipative and comply with industry standards EIA-481/EIA-541.

Go to: www.minicircuits.com/pages/pdfs/tape.pdf



INTERNET <http://www.minicircuits.com>

P.O. Box 350166, Brooklyn, New York 11235-0003 (718) 934-4500 Fax (718) 332-4661

Distribution Centers NORTH AMERICA 800-654-7949 • 417-335-5935 • Fax 417-335-5945 • EUROPE 44-1252-832600 • Fax 44-1252-837010

Mini-Circuits ISO 9001 & ISO 14001 Certified

THIRD ANGLE PROJECTION

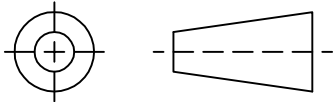

REVISIONS

REV	ECN No.	DESCRIPTION	DATE	DR	AUTH
OR	M168200	NEW RELEASE	05/31/18	NP	SL

SUGGESTED MOUNTING CONFIGURATION
FOR GE0805C-3 CASE STYLE, "04FL01" PIN CODE

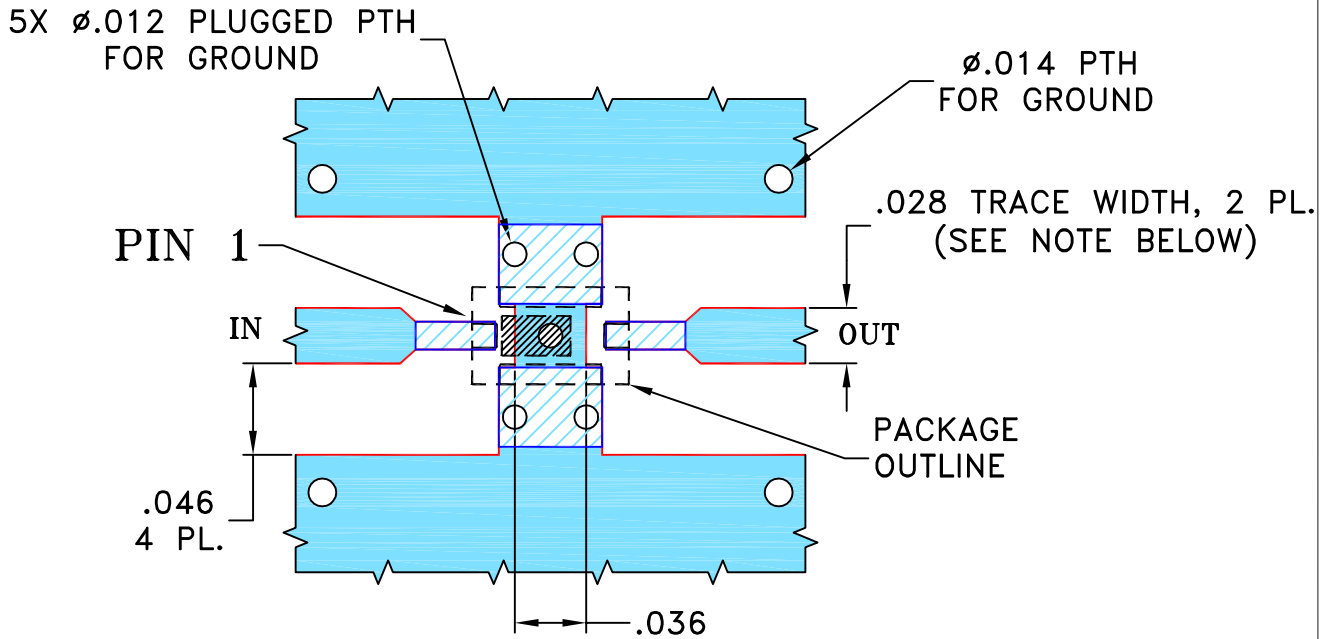

NOTES:

- TRACE WIDTH IS SHOWN FOR FR4, GRADE IT-180TC (ITEQ CORP.) WITH DIELECTRIC THICKNESS $.016 \pm .0015$. COPPER: 1/2 OZ. EACH SIDE. FOR OTHER MATERIALS TRACE WIDTH AND GAP MAY NEED TO BE MODIFIED.
- BOTTOM SIDE OF THE PCB IS CONTINUOUS GROUND PLANE.

 DENOTES PCB COPPER LAYOUT WITH SMOBC (SOLDER MASK OVER BARE COPPER).

 DENOTES COPPER LAND PATTERN FREE OF SOLDER MASK.

UNLESS OTHERWISE SPECIFIED	INITIALS	DATE
DRAWN	NP	05/30/18
CHECKED	GF	05/30/18
APPROVED	SL	05/31/18

 **Mini-Circuits**[®] 13 Neptune Avenue
 Brooklyn NY 11235

PL, 04FL01, GE0805C-3, TB-1022+

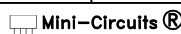
 Mini-Circuits[®]

THIS DOCUMENT AND ITS CONTENTS ARE THE PROPERTY OF MINI-CIRCUITS. EXCEPT FOR USE EXPRESSLY GRANTED, IN WRITING, TO ITS VENDORS, VENDEE AND THE UNITED STATES GOVERNMENT, MINI-CIRCUITS RESERVES ALL PROPRIETARY DESIGN, USE, MANUFACTURING AND REPRODUCTION RIGHTS THERETO. THESE CONTENTS SHALL NOT BE USED, DUPLICATED OR DISCLOSED TO ANY OUTSIDE PARTY, IN WHOLE OR IN PART, WITHOUT WRITTEN PERMISSION OF MINI-CIRCUITS.

ASHEETA1.DWG REV:A DATE:01/12/95

SIZE	CODE IDENT	DRAWING NO:	REV:
A	15542	98-PL-547	OR
FILE:	98PL547	SCALE: 10:1	SHEET: 1 OF 1

Evaluation Board and Circuit

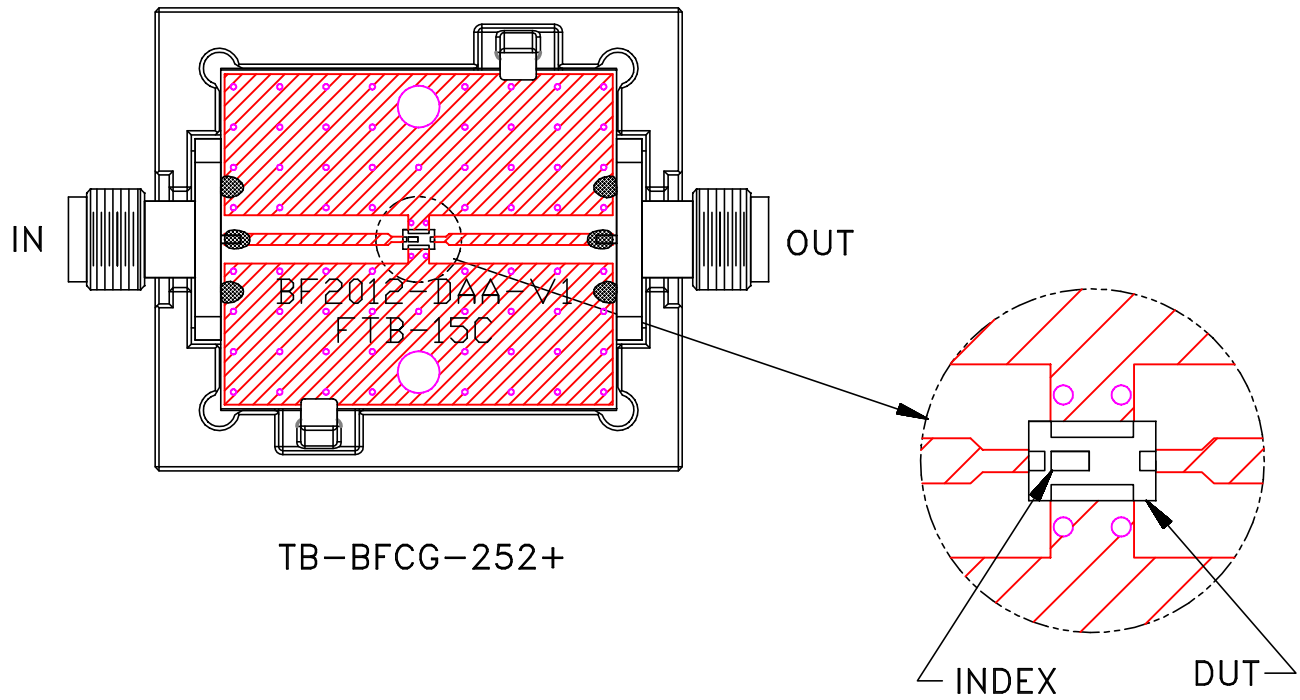

TB-BFCG-252+

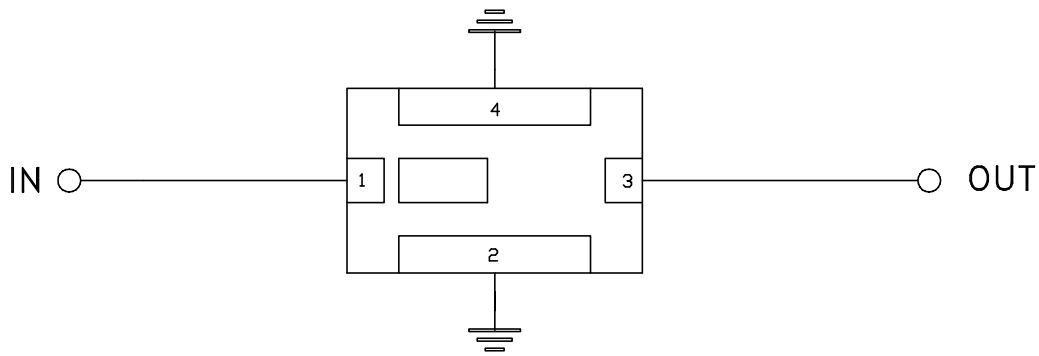

Schematic Diagram

Notes:

1. 50 Ohm SMA Female connectors.
2. PCB Material: FR4 or equivalent,
Dielectric Constant=4.5, Thickness=.016 inch.

 **Mini-Circuits®**



All Mini-Circuits products are manufactured under exacting quality assurance and control standards, and are capable of meeting published specifications after being subjected to any or all of the following physical and environmental test.

Specification	Test/Inspection Condition	Reference/Spec
Operating Temperature	-55° to 125° C Ambient Environment	Individual Model Data Sheet
Storage Temperature	-55° to 125° C Ambient Environment	Individual Model Data Sheet
Humidity	90 to 95% RH, 240 hours, 50°C	MIL-STD-202, Method 103, Condition A, Except 50°C and end-point electrical test done within 12 hours
Solder Reflow Heat	Sn-Pb Eutectic Process: 225°C peak Pb-Free Process: 250°C peak	J-STD-020C, Table 4-1, 4-2 and 5-2; Figure 5-1
Solderability	10X Magnification	J-STD-002, Para 4.2.5, Test S, 95% Coverage
Vibration (High Frequency)	20g peak, 10-2000 Hz, 12 times in each of three perpendicular directions (total 36)	MIL-STD-202, Method 204, Condition D
Mechanical Shock	50g, 11 ms, 1/2-sine, 18 shocks: 3 each direction, each of 3 axes	MIL-STD-202, Method 213, Condition A