



STRIPLINE SURFACE MOUNT

Bi-Directional Coupler

BDCH-35-272+

50Ω 700 to 2700 MHz 35 dB 150W

KEY FEATURES

- High power handling, up to 150W
- Ultra wideband, 700 to 2700 MHz
- Low insertion loss, 0.2 dB



Generic photo used for illustration purposes only

APPLICATIONS

- VHF/UHF high power radio
- Transmission signal monitoring
- Antenna reflection monitoring
- Distributed antenna systems (DAS)
- Wireless transmitters

FUNCTIONAL DIAGRAM

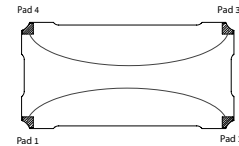

PRODUCT OVERVIEW

Mini-Circuits BDCH-35-272+ high-power bi-directional coupler provides high power handling up to 150W and insertion loss of 0.2 dB Typ. Covering frequencies from 700 to 2700 MHz, it supports a wide variety of applications from military to various cellular base station applications and more.

Excellent return loss at all ports of 23 dB typical provides superb matching over the full frequency range. The coupler is designed into an open printed laminate (1.0 x 0.5 x 0.051") with wrap-around terminations for good solderability and easy visual inspection.

ELECTRICAL SPECIFICATIONS^{1,2} AT +25°C

Parameter	Frequency (MHz)	Min.	Typ.	Max.	Units
Frequency Range		700		2700	MHz
Insertion Loss	700-2700	-	0.2	0.3	dB
Coupling Nominal	700-2700	-	35.8±1	-	dB
Coupling Flatness (±)	700-2700	-	±1.1	-	dB
	800-2500	-	±1	-	
Directivity	700-2700	10	16	-	dB
	800-2500	12	18	-	
Return Loss (Input/Output)	700-2700	17	23	-	dB
Return Loss (Coupled Forward/Reverse)	700-2700	17	23	-	dB
Thermal Resistance ³	700-2700	-	-	0.5	°C/W

1. Tested on Evaluation Board TB-863-1+. De-embedded to the device reference plane.

2. Model is symmetrical and all ports are interchangeable, see Port Function Description/Configuration table for details and S-Parameters for actual performance.

3. Thermal Resistance is defined as, example (θ_{jc})= (Hot Spot Temperature on DUT - Base Plate Temperature)/Input Power)

ABSOLUTE MAXIMUM RATINGS⁴

Operating Case Temperature ⁵	-55 °C to +105 °C	
Storage Temperature	-55 °C to +105 °C	
Power Input	+85 °C case	150 W
	+95 °C case	120 W
	+105 °C case	90 W
DC Current	2.5 A	

4. Permanent damage may occur if any of these limits are exceeded.

5. Case temperature is defined as temperature on base plate.





TYPICAL PERFORMANCE GRAPHS

Note : Data corresponds to Configuration A at +25°C unless specified otherwise.

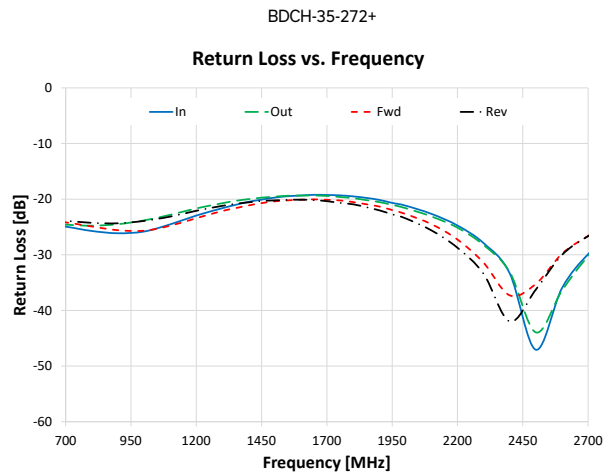
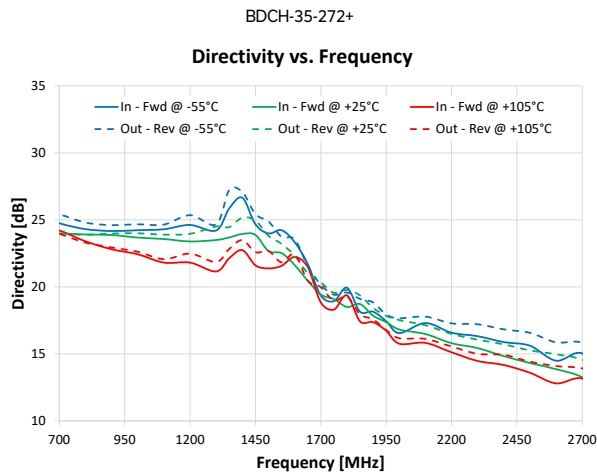
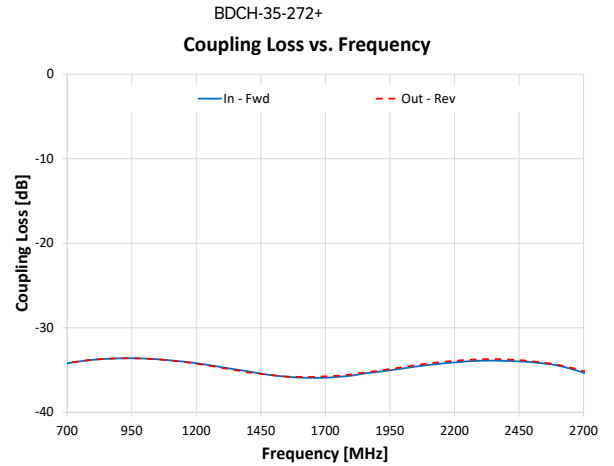
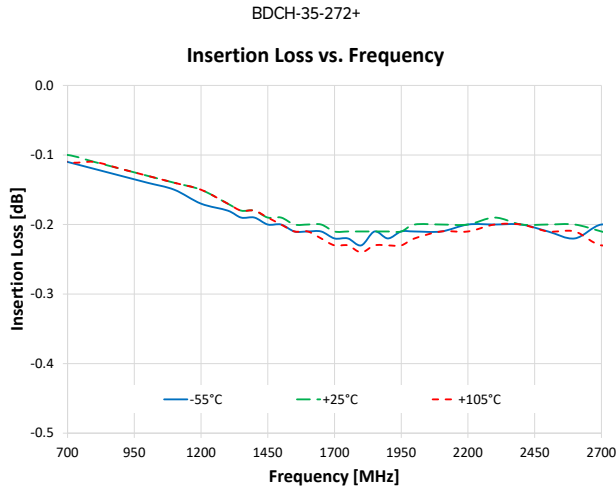



STRIPLINE SURFACE MOUNT

Bi-Directional Coupler

BDCH-35-272+

50Ω 700 to 2700 MHz 35 dB 150W

FUNCTIONAL DIAGRAM

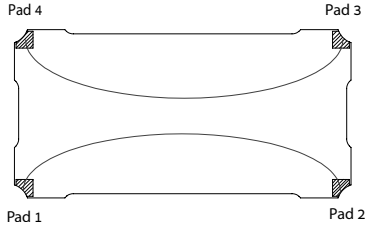

Figure 1. BDCH-35-272+ Functional Diagram

PAD DESCRIPTION/CONFIGURATION⁶

Function	Pad Number	Description
Input	1	Connects to RF Input Port
Output	2	Connects to RF Output Port
Coupled Forward	4	Connects to Coupled Forward Port
Coupled Reverse	3	Connects to Coupled Reverse Port
Ground	5	Connects to Ground

Configuration	Input	Output	Coupled Forward	Coupled Reverse
A	1	2	4	3
B	2	1	3	4
C	3	4	2	1
D	4	3	1	2

6. Model is symmetrical and all ports are interchangeable, see Port Function Description/Configuration table for details and S-Parameters for actual performance.

SUGGESTED PCB LAYOUT (PL-538)

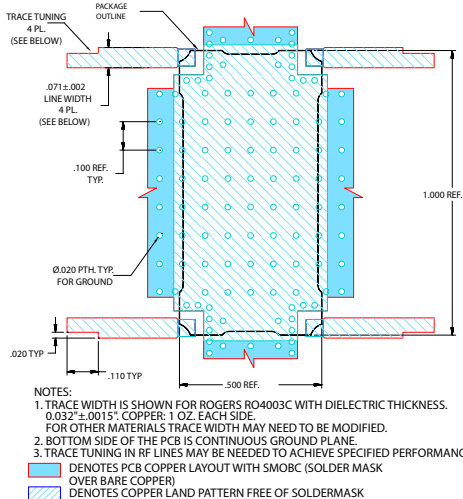
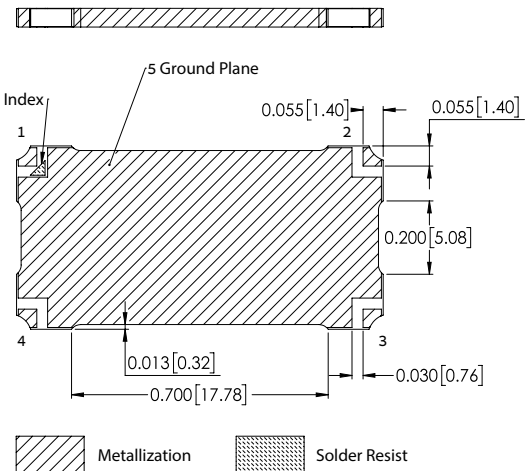
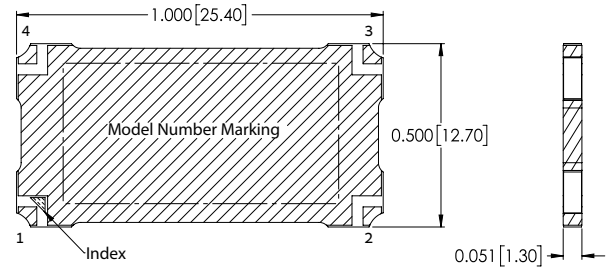

Figure 2. Suggested PCB Layout PL-538

CASE STYLE DRAWING (PQ2098)



NOTES:

1. Base material: Printed wiring laminate.
2. Termination finish: 2-5 μinch (.05-.13 microns) Immersion Gold.
3. Weight: 2.0 grams
4. Marking may contain other features or characters for internal lot control.

PRODUCT MARKING*: BDCH-35-272+

*Marking may contain other features or characters for internal lot control.



STRIPLINE SURFACE MOUNT

Bi-Directional Coupler

BDCH-35-272+

50Ω 700 to 2700 MHz 35 dB 150W

ADDITIONAL DETAILED INFORMATION IS AVAILABLE ON OUR DASH BOARD.

[CLICK HERE](#)

Performance Data & Graphs	Data
	Graphs
	S-Parameter (S4P Files) Data Set (.zip file) De-embedded to device pads
Case Style	PQ2098 Lead Finish: 2-5 inch (0.05-0.13 microns) Immersion Gold.
RoHS Status	Compliant
Tape and Reel	F118
Suggested Layout for PCB Design	PL-538
Evaluation Board	TB-863-1+
	Gerber File
Environmental Rating	ENV02T8

NOTES

- A. Performance and quality attributes and conditions not expressly stated in this specification document are intended to be excluded and do not form a part of this specification document.
- B. Electrical specifications and performance data contained in this specification document are based on Mini-Circuits' applicable established test performance criteria and measurement instructions.
- C. The parts covered by this specification document are subject to Mini-Circuits' standard limited warranty and terms and conditions (collectively, "Standard Terms"); Purchasers of this part are entitled to the rights and benefits contained therein. For a full statement of the standard terms and the exclusive rights and remedies thereunder, please visit Mini-Circuits' website at www.minicircuits.com/terms/viewterm.html



Bi-Directional Coupler

BDCH-35-272+

Typical Performance Data

Test Conditions: Input Power = +5 dbm, Temperature = -55°C, Configuration A.

Freq. (MHz)	I. Loss (dB) In - Out	Coupling (dB)		Directivity (dB) In - Fwd	Return Loss (dB)			
		In - Fwd	Out - Rev		In	Out	Fwd	Rev
50	-0.02	-54.94	-54.95	25.53	-45.09	-45.30	-44.49	-44.59
100	-0.03	-48.99	-48.99	25.05	-35.38	-35.42	-36.29	-36.31
200	-0.04	-43.16	-43.16	24.22	-26.29	-26.37	-26.96	-27.14
300	-0.06	-39.90	-39.90	25.27	-26.03	-26.09	-25.15	-25.21
400	-0.06	-37.75	-37.75	26.17	-26.03	-26.10	-25.38	-25.38
500	-0.08	-36.26	-36.26	26.37	-25.79	-25.79	-25.73	-25.63
600	-0.09	-35.22	-35.22	25.80	-25.57	-25.40	-25.60	-25.46
700	-0.10	-34.53	-34.52	25.37	-25.97	-25.55	-24.77	-24.37
800	-0.10	-34.08	-34.09	24.49	-25.90	-24.93	-24.77	-24.12
900	-0.11	-33.93	-33.94	24.26	-25.62	-24.04	-25.49	-24.11
1000	-0.12	-33.96	-33.99	24.31	-25.49	-23.45	-25.04	-23.28
1100	-0.13	-34.18	-34.20	23.66	-24.48	-22.65	-24.62	-22.80
1200	-0.15	-34.53	-34.60	23.42	-22.95	-21.50	-23.81	-22.11
1300	-0.16	-34.95	-35.02	22.56	-21.51	-20.55	-22.31	-21.20
1350	-0.17	-35.16	-35.49	24.60	-20.78	-19.95	-21.87	-20.80
1400	-0.18	-35.60	-35.55	24.26	-20.12	-19.61	-21.25	-20.51
1450	-0.18	-35.63	-35.82	22.75	-19.76	-19.39	-20.63	-20.15
1500	-0.19	-35.94	-35.96	22.85	-19.49	-19.30	-20.10	-19.95
1550	-0.19	-35.99	-36.18	23.35	-19.32	-19.23	-19.80	-19.74
1600	-0.19	-36.17	-36.15	21.89	-19.19	-19.23	-19.67	-19.64
1650	-0.19	-36.22	-36.21	20.81	-19.10	-19.31	-19.55	-19.71
1700	-0.20	-36.19	-36.03	18.68	-19.18	-19.50	-19.55	-19.95
1750	-0.20	-36.10	-35.88	18.38	-19.30	-19.79	-19.72	-20.36
1800	-0.20	-35.76	-35.95	19.38	-19.52	-20.01	-20.25	-20.77
1850	-0.20	-35.58	-35.61	17.92	-19.74	-20.40	-20.72	-21.42
1900	-0.20	-35.40	-35.29	17.83	-20.10	-20.85	-21.19	-22.22
1950	-0.20	-35.14	-35.07	17.30	-20.68	-21.50	-21.94	-23.15
2000	-0.19	-34.95	-34.87	16.57	-21.39	-22.30	-22.94	-24.07
2100	-0.19	-34.55	-34.36	17.06	-23.51	-24.53	-24.90	-26.42
2200	-0.19	-34.22	-34.05	16.45	-27.01	-28.21	-28.01	-29.94
2300	-0.18	-33.98	-33.85	16.11	-32.98	-35.46	-33.50	-36.19
2400	-0.18	-34.06	-33.93	15.95	-41.68	-52.35	-46.34	-54.25
2500	-0.19	-34.21	-34.15	16.05	-38.01	-37.96	-36.97	-37.47
2600	-0.19	-34.66	-34.65	15.49	-37.30	-37.10	-33.14	-33.66
2700	-0.19	-35.30	-35.22	14.85	-36.95	-38.30	-30.44	-31.09
2800	-0.19	-36.35	-36.40	12.77	-31.95	-33.87	-27.03	-26.97
2900	-0.20	-37.94	-37.70	10.49	-28.01	-28.51	-23.73	-23.24
3000	-0.21	-39.81	-39.89	9.65	-24.08	-24.20	-21.06	-20.82
3100	-0.23	-42.63	-42.48	8.87	-21.04	-21.08	-19.39	-19.23
3200	-0.26	-46.76	-47.93	1.51	-19.72	-19.76	-18.73	-18.44
3300	-0.29	-52.30	-51.46	1.15	-19.23	-19.21	-17.82	-17.68

Bi-Directional Coupler

BDCH-35-272+

Typical Performance Data

Test Conditions: Input Power = +5 dbm, Temperature = -55°C, Configuration B.

Freq. (MHz)	I. Loss (dB) In - Out	Coupling (dB)		Directivity (dB) In - Fwd	Return Loss (dB)			
		In - Fwd	Out - Rev		In	Out	Fwd	Rev
50	-0.02	-54.95	-54.94	26.17	-45.30	-45.09	-44.59	-44.49
100	-0.03	-48.99	-48.99	25.26	-35.42	-35.38	-36.31	-36.29
200	-0.05	-43.16	-43.16	24.47	-26.37	-26.29	-27.14	-26.96
300	-0.06	-39.90	-39.90	25.44	-26.09	-26.03	-25.21	-25.15
400	-0.07	-37.75	-37.75	25.81	-26.10	-26.03	-25.38	-25.38
500	-0.08	-36.26	-36.26	25.91	-25.79	-25.79	-25.63	-25.73
600	-0.09	-35.22	-35.22	26.10	-25.40	-25.57	-25.46	-25.60
700	-0.10	-34.52	-34.53	25.86	-25.55	-25.97	-24.37	-24.77
800	-0.11	-34.09	-34.08	24.85	-24.93	-25.90	-24.12	-24.77
900	-0.12	-33.94	-33.93	24.67	-24.04	-25.62	-24.11	-25.49
1000	-0.13	-33.99	-33.96	24.82	-23.45	-25.49	-23.28	-25.04
1100	-0.14	-34.20	-34.18	24.45	-22.65	-24.48	-22.80	-24.62
1200	-0.15	-34.60	-34.53	24.69	-21.50	-22.95	-22.11	-23.81
1300	-0.17	-35.02	-34.95	23.54	-20.55	-21.51	-21.20	-22.31
1350	-0.18	-35.49	-35.16	27.32	-19.95	-20.78	-20.80	-21.87
1400	-0.18	-35.55	-35.60	25.16	-19.61	-20.12	-20.51	-21.25
1450	-0.19	-35.82	-35.63	24.08	-19.39	-19.76	-20.15	-20.63
1500	-0.20	-35.96	-35.94	23.41	-19.30	-19.49	-19.95	-20.10
1550	-0.20	-36.18	-35.99	22.85	-19.23	-19.32	-19.74	-19.80
1600	-0.20	-36.15	-36.17	21.84	-19.23	-19.19	-19.64	-19.67
1650	-0.20	-36.21	-36.22	20.65	-19.31	-19.10	-19.71	-19.55
1700	-0.21	-36.03	-36.19	19.15	-19.50	-19.18	-19.95	-19.55
1750	-0.21	-35.88	-36.10	18.55	-19.79	-19.30	-20.36	-19.72
1800	-0.22	-35.95	-35.76	19.82	-20.01	-19.52	-20.77	-20.25
1850	-0.21	-35.61	-35.58	18.09	-20.40	-19.74	-21.42	-20.72
1900	-0.21	-35.29	-35.40	17.51	-20.85	-20.10	-22.22	-21.19
1950	-0.21	-35.07	-35.14	16.73	-21.50	-20.68	-23.15	-21.94
2000	-0.21	-34.87	-34.95	16.51	-22.30	-21.39	-24.07	-22.94
2100	-0.20	-34.36	-34.55	16.46	-24.53	-23.51	-26.42	-24.90
2200	-0.20	-34.05	-34.22	16.24	-28.21	-27.01	-29.94	-28.01
2300	-0.19	-33.85	-33.98	16.00	-35.46	-32.98	-36.19	-33.50
2400	-0.19	-33.93	-34.06	15.80	-52.35	-41.68	-54.25	-46.34
2500	-0.20	-34.15	-34.21	15.39	-37.96	-38.01	-37.47	-36.97
2600	-0.20	-34.65	-34.66	15.59	-37.10	-37.30	-33.66	-33.14
2700	-0.20	-35.22	-35.30	14.78	-38.30	-36.95	-31.09	-30.44
2800	-0.20	-36.40	-36.35	13.50	-33.87	-31.95	-26.97	-27.03
2900	-0.21	-37.70	-37.94	11.87	-28.51	-28.01	-23.24	-23.73
3000	-0.22	-39.89	-39.81	10.94	-24.20	-24.08	-20.82	-21.06
3100	-0.24	-42.48	-42.63	10.80	-21.08	-21.04	-19.23	-19.39
3200	-0.27	-47.93	-46.76	1.75	-19.76	-19.72	-18.44	-18.73
3300	-0.30	-51.46	-52.30	3.00	-19.21	-19.23	-17.68	-17.82

Bi-Directional Coupler

BDCH-35-272+

Typical Performance Data

Test Conditions: Input Power = +5 dbm, Temperature = -55°C, Configuration C.

Freq. (MHz)	I. Loss (dB) In - Out	Coupling (dB)		Directivity (dB) In - Fwd	Return Loss (dB)			
		In - Fwd	Out - Rev		In	Out	Fwd	Rev
50	-0.02	-54.93	-54.94	25.70	-44.59	-44.49	-45.30	-45.09
100	-0.03	-48.98	-48.99	25.10	-36.31	-36.29	-35.42	-35.38
200	-0.05	-43.16	-43.17	24.31	-27.14	-26.96	-26.37	-26.29
300	-0.07	-39.89	-39.90	25.25	-25.21	-25.15	-26.09	-26.03
400	-0.07	-37.74	-37.76	26.01	-25.38	-25.38	-26.10	-26.03
500	-0.09	-36.25	-36.27	26.10	-25.63	-25.73	-25.79	-25.79
600	-0.10	-35.21	-35.23	25.54	-25.46	-25.60	-25.40	-25.57
700	-0.11	-34.51	-34.53	25.02	-24.37	-24.77	-25.55	-25.97
800	-0.12	-34.08	-34.08	24.16	-24.12	-24.77	-24.93	-25.90
900	-0.12	-33.93	-33.94	23.95	-24.11	-25.49	-24.04	-25.62
1000	-0.14	-33.98	-33.97	24.03	-23.28	-25.04	-23.45	-25.49
1100	-0.14	-34.19	-34.19	23.36	-22.80	-24.62	-22.65	-24.48
1200	-0.16	-34.59	-34.54	23.35	-22.11	-23.81	-21.50	-22.95
1300	-0.17	-35.01	-34.97	22.46	-21.20	-22.31	-20.55	-21.51
1350	-0.18	-35.48	-35.16	24.38	-20.80	-21.87	-19.95	-20.78
1400	-0.18	-35.54	-35.60	24.43	-20.51	-21.25	-19.61	-20.12
1450	-0.19	-35.80	-35.64	22.67	-20.15	-20.63	-19.39	-19.76
1500	-0.20	-35.96	-35.95	22.88	-19.95	-20.10	-19.30	-19.49
1550	-0.21	-36.17	-36.00	23.18	-19.74	-19.80	-19.23	-19.32
1600	-0.21	-36.14	-36.18	22.00	-19.64	-19.67	-19.23	-19.19
1650	-0.21	-36.20	-36.23	20.97	-19.71	-19.55	-19.31	-19.10
1700	-0.22	-36.03	-36.20	18.93	-19.95	-19.55	-19.50	-19.18
1750	-0.22	-35.88	-36.11	18.62	-20.36	-19.72	-19.79	-19.30
1800	-0.22	-35.94	-35.77	19.25	-20.77	-20.25	-20.01	-19.52
1850	-0.21	-35.60	-35.60	17.87	-21.42	-20.72	-20.40	-19.74
1900	-0.22	-35.28	-35.42	17.95	-22.22	-21.19	-20.85	-20.10
1950	-0.21	-35.06	-35.16	17.25	-23.15	-21.94	-21.50	-20.68
2000	-0.21	-34.86	-34.96	16.59	-24.07	-22.94	-22.30	-21.39
2100	-0.21	-34.35	-34.56	17.05	-26.42	-24.90	-24.53	-23.51
2200	-0.21	-34.04	-34.23	16.45	-29.94	-28.01	-28.21	-27.01
2300	-0.20	-33.84	-34.00	16.01	-36.19	-33.50	-35.46	-32.98
2400	-0.21	-33.92	-34.07	15.85	-54.25	-46.34	-52.35	-41.68
2500	-0.22	-34.15	-34.23	15.90	-37.47	-36.97	-37.96	-38.01
2600	-0.22	-34.64	-34.67	15.36	-33.66	-33.14	-37.10	-37.30
2700	-0.21	-35.22	-35.32	14.86	-31.09	-30.44	-38.30	-36.95
2800	-0.23	-36.39	-36.37	12.68	-26.97	-27.03	-33.87	-31.95
2900	-0.24	-37.69	-37.95	10.67	-23.24	-23.73	-28.51	-28.01
3000	-0.25	-39.88	-39.82	9.55	-20.82	-21.06	-24.20	-24.08
3100	-0.28	-42.48	-42.64	9.02	-19.23	-19.39	-21.08	-21.04
3200	-0.30	-47.93	-46.78	0.42	-18.44	-18.73	-19.76	-19.72
3300	-0.34	-51.49	-52.36	0.64	-17.68	-17.82	-19.21	-19.23

Bi-Directional Coupler

BDCH-35-272+

Typical Performance Data

Test Conditions: Input Power = +5 dbm, Temperature = -55°C, Configuration D.

Freq. (MHz)	I. Loss (dB) In - Out	Coupling (dB)		Directivity (dB) In - Fwd	Return Loss (dB)			
		In - Fwd	Out - Rev		In	Out	Fwd	Rev
50	-0.02	-54.94	-54.93	25.96	-44.49	-44.59	-45.09	-45.30
100	-0.04	-48.99	-48.98	25.10	-36.29	-36.31	-35.38	-35.42
200	-0.05	-43.17	-43.16	24.41	-26.96	-27.14	-26.29	-26.37
300	-0.07	-39.90	-39.89	25.52	-25.15	-25.21	-26.03	-26.09
400	-0.08	-37.76	-37.74	25.92	-25.38	-25.38	-26.03	-26.10
500	-0.09	-36.27	-36.25	26.15	-25.73	-25.63	-25.79	-25.79
600	-0.10	-35.23	-35.21	26.51	-25.60	-25.46	-25.57	-25.40
700	-0.11	-34.53	-34.51	26.29	-24.77	-24.37	-25.97	-25.55
800	-0.12	-34.08	-34.08	25.21	-24.77	-24.12	-25.90	-24.93
900	-0.13	-33.94	-33.93	25.08	-25.49	-24.11	-25.62	-24.04
1000	-0.14	-33.97	-33.98	25.13	-25.04	-23.28	-25.49	-23.45
1100	-0.15	-34.19	-34.19	24.78	-24.62	-22.80	-24.48	-22.65
1200	-0.17	-34.54	-34.59	24.86	-23.81	-22.11	-22.95	-21.50
1300	-0.18	-34.97	-35.01	23.61	-22.31	-21.20	-21.51	-20.55
1350	-0.19	-35.16	-35.48	27.51	-21.87	-20.80	-20.78	-19.95
1400	-0.19	-35.60	-35.54	25.17	-21.25	-20.51	-20.12	-19.61
1450	-0.20	-35.64	-35.80	24.15	-20.63	-20.15	-19.76	-19.39
1500	-0.20	-35.95	-35.96	23.39	-20.10	-19.95	-19.49	-19.30
1550	-0.21	-36.00	-36.17	22.98	-19.80	-19.74	-19.32	-19.23
1600	-0.22	-36.18	-36.14	21.66	-19.67	-19.64	-19.19	-19.23
1650	-0.22	-36.23	-36.20	20.50	-19.55	-19.71	-19.10	-19.31
1700	-0.22	-36.20	-36.03	18.87	-19.55	-19.95	-19.18	-19.50
1750	-0.22	-36.11	-35.88	18.23	-19.72	-20.36	-19.30	-19.79
1800	-0.22	-35.77	-35.94	19.97	-20.25	-20.77	-19.52	-20.01
1850	-0.22	-35.60	-35.60	18.13	-20.72	-21.42	-19.74	-20.40
1900	-0.22	-35.42	-35.28	17.33	-21.19	-22.22	-20.10	-20.85
1950	-0.21	-35.16	-35.06	16.67	-21.94	-23.15	-20.68	-21.50
2000	-0.21	-34.96	-34.86	16.43	-22.94	-24.07	-21.39	-22.30
2100	-0.21	-34.56	-34.35	16.36	-24.90	-26.42	-23.51	-24.53
2200	-0.21	-34.23	-34.04	16.21	-28.01	-29.94	-27.01	-28.21
2300	-0.21	-34.00	-33.84	16.08	-33.50	-36.19	-32.98	-35.46
2400	-0.21	-34.07	-33.92	15.86	-46.34	-54.25	-41.68	-52.35
2500	-0.22	-34.23	-34.15	15.49	-36.97	-37.47	-38.01	-37.96
2600	-0.22	-34.67	-34.64	15.75	-33.14	-33.66	-37.30	-37.10
2700	-0.22	-35.32	-35.22	14.77	-30.44	-31.09	-36.95	-38.30
2800	-0.23	-36.37	-36.39	13.60	-27.03	-26.97	-31.95	-33.87
2900	-0.24	-37.95	-37.69	11.70	-23.73	-23.24	-28.01	-28.51
3000	-0.26	-39.82	-39.88	11.06	-21.06	-20.82	-24.08	-24.20
3100	-0.29	-42.64	-42.48	10.70	-19.39	-19.23	-21.04	-21.08
3200	-0.31	-46.78	-47.93	2.92	-18.73	-18.44	-19.72	-19.76
3300	-0.34	-52.36	-51.49	2.16	-17.82	-17.68	-19.23	-19.21

Bi-Directional Coupler

BDCH-35-272+

Typical Performance Data

Test Conditions: Input Power = +5 dbm, Temperature = +25°C, Configuration A.

Freq. (MHz)	I. Loss (dB) In - Out	Coupling (dB)		Directivity (dB) In - Fwd	Return Loss (dB)			
		In - Fwd	Out - Rev		In	Out	Fwd	Rev
50	-0.03	-54.79	-54.81	25.89	-38.69	-38.92	-39.18	-39.27
100	-0.04	-48.86	-48.87	26.53	-34.27	-34.39	-34.40	-34.42
200	-0.05	-43.05	-43.04	26.33	-29.22	-29.43	-29.12	-29.45
300	-0.07	-39.80	-39.79	26.00	-26.76	-26.92	-26.65	-26.74
400	-0.08	-37.67	-37.65	25.44	-25.33	-25.40	-25.20	-25.20
500	-0.09	-36.18	-36.17	24.92	-24.65	-24.67	-24.38	-24.27
600	-0.10	-35.15	-35.14	24.44	-24.55	-24.41	-24.05	-23.88
700	-0.11	-34.46	-34.44	24.23	-24.98	-24.60	-24.26	-23.89
800	-0.12	-34.04	-34.04	24.09	-25.63	-24.68	-24.69	-23.98
900	-0.12	-33.88	-33.88	24.02	-25.98	-24.36	-25.09	-23.85
1000	-0.14	-33.92	-33.93	23.78	-25.75	-23.74	-25.15	-23.40
1100	-0.15	-34.14	-34.15	23.34	-24.65	-22.84	-24.50	-22.80
1200	-0.16	-34.50	-34.54	23.11	-23.19	-21.79	-23.47	-21.97
1300	-0.17	-34.99	-35.04	22.77	-21.89	-20.92	-22.37	-21.25
1350	-0.18	-35.26	-35.28	22.53	-21.32	-20.53	-21.91	-20.98
1400	-0.19	-35.49	-35.52	21.86	-20.77	-20.25	-21.43	-20.77
1450	-0.19	-35.73	-35.71	21.56	-20.35	-19.98	-21.05	-20.58
1500	-0.20	-35.91	-35.91	20.68	-19.97	-19.80	-20.72	-20.47
1550	-0.20	-36.06	-36.08	20.83	-19.71	-19.63	-20.51	-20.39
1600	-0.21	-36.11	-36.13	20.39	-19.59	-19.60	-20.35	-20.37
1650	-0.21	-36.13	-36.10	20.09	-19.43	-19.60	-20.26	-20.45
1700	-0.21	-36.11	-36.04	19.15	-19.43	-19.65	-20.29	-20.57
1750	-0.21	-36.02	-35.92	18.43	-19.46	-19.83	-20.33	-20.81
1800	-0.21	-35.86	-35.78	18.03	-19.62	-20.02	-20.54	-21.02
1850	-0.21	-35.64	-35.53	17.95	-19.83	-20.35	-20.86	-21.47
1900	-0.22	-35.43	-35.30	17.49	-20.15	-20.67	-21.20	-21.92
1950	-0.22	-35.21	-35.07	17.22	-20.62	-21.12	-21.72	-22.52
2000	-0.21	-35.01	-34.83	16.61	-21.06	-21.67	-22.29	-23.08
2100	-0.21	-34.57	-34.38	16.39	-22.42	-23.08	-23.89	-24.87
2200	-0.21	-34.23	-34.04	15.90	-24.35	-25.00	-26.25	-27.20
2300	-0.21	-34.01	-33.85	15.63	-27.20	-27.93	-29.89	-30.64
2400	-0.21	-34.04	-33.86	15.04	-31.91	-32.42	-36.35	-36.71
2500	-0.21	-34.21	-34.09	14.39	-43.58	-43.27	-49.66	-45.83
2600	-0.21	-34.60	-34.56	13.64	-38.45	-39.28	-34.19	-34.44
2700	-0.22	-35.33	-35.24	13.02	-30.60	-31.22	-28.90	-29.06
2800	-0.23	-36.52	-36.48	11.07	-26.54	-26.93	-25.53	-25.55
2900	-0.25	-37.66	-37.79	10.96	-23.94	-24.20	-23.07	-22.90
3000	-0.26	-39.59	-39.61	9.70	-22.22	-22.27	-21.30	-21.03
3100	-0.27	-42.50	-42.39	7.47	-20.93	-20.96	-19.74	-19.53
3200	-0.29	-46.80	-46.94	3.14	-20.21	-20.19	-18.57	-18.41
3300	-0.30	-53.96	-54.58	1.56	-19.61	-19.57	-17.54	-17.48

Bi-Directional Coupler

BDCH-35-272+

Typical Performance Data

Test Conditions: Input Power = +5 dbm, Temperature = +25°C, Configuration B.

Freq. (MHz)	I. Loss (dB) In - Out	Coupling (dB)		Directivity (dB) In - Fwd	Return Loss (dB)			
		In - Fwd	Out - Rev		In	Out	Fwd	Rev
50	-0.02	-54.81	-54.79	26.12	-38.92	-38.69	-39.27	-39.18
100	-0.03	-48.87	-48.86	26.73	-34.39	-34.27	-34.42	-34.40
200	-0.05	-43.04	-43.05	26.48	-29.43	-29.22	-29.45	-29.12
300	-0.06	-39.79	-39.80	26.11	-26.92	-26.76	-26.74	-26.65
400	-0.08	-37.65	-37.67	25.50	-25.40	-25.33	-25.20	-25.20
500	-0.09	-36.17	-36.18	24.92	-24.67	-24.65	-24.27	-24.38
600	-0.10	-35.14	-35.15	24.43	-24.41	-24.55	-23.88	-24.05
700	-0.10	-34.44	-34.46	24.31	-24.60	-24.98	-23.89	-24.26
800	-0.11	-34.04	-34.04	24.17	-24.68	-25.63	-23.98	-24.69
900	-0.12	-33.88	-33.88	24.19	-24.36	-25.98	-23.85	-25.09
1000	-0.13	-33.93	-33.92	24.15	-23.74	-25.75	-23.40	-25.15
1100	-0.14	-34.15	-34.14	23.85	-22.84	-24.65	-22.80	-24.50
1200	-0.15	-34.54	-34.50	23.94	-21.79	-23.19	-21.97	-23.47
1300	-0.17	-35.04	-34.99	23.98	-20.92	-21.89	-21.25	-22.37
1350	-0.18	-35.28	-35.26	23.69	-20.53	-21.32	-20.98	-21.91
1400	-0.18	-35.52	-35.49	23.19	-20.25	-20.77	-20.77	-21.43
1450	-0.19	-35.71	-35.73	22.73	-19.98	-20.35	-20.58	-21.05
1500	-0.20	-35.91	-35.91	21.85	-19.80	-19.97	-20.47	-20.72
1550	-0.20	-36.08	-36.06	21.15	-19.63	-19.71	-20.39	-20.51
1600	-0.20	-36.13	-36.11	20.88	-19.60	-19.59	-20.37	-20.35
1650	-0.21	-36.10	-36.13	20.47	-19.60	-19.43	-20.45	-20.26
1700	-0.21	-36.04	-36.11	19.76	-19.65	-19.43	-20.57	-20.29
1750	-0.21	-35.92	-36.02	18.87	-19.83	-19.46	-20.81	-20.33
1800	-0.21	-35.78	-35.86	18.54	-20.02	-19.62	-21.02	-20.54
1850	-0.21	-35.53	-35.64	18.19	-20.35	-19.83	-21.47	-20.86
1900	-0.22	-35.30	-35.43	17.30	-20.67	-20.15	-21.92	-21.20
1950	-0.22	-35.07	-35.21	16.86	-21.12	-20.62	-22.52	-21.72
2000	-0.21	-34.83	-35.01	16.53	-21.67	-21.06	-23.08	-22.29
2100	-0.21	-34.38	-34.57	16.15	-23.08	-22.42	-24.87	-23.89
2200	-0.21	-34.04	-34.23	15.65	-25.00	-24.35	-27.20	-26.25
2300	-0.21	-33.85	-34.01	15.10	-27.93	-27.20	-30.64	-29.89
2400	-0.21	-33.86	-34.04	14.85	-32.42	-31.91	-36.71	-36.35
2500	-0.20	-34.09	-34.21	14.40	-43.27	-43.58	-45.83	-49.66
2600	-0.21	-34.56	-34.60	13.94	-39.28	-38.45	-34.44	-34.19
2700	-0.22	-35.24	-35.33	13.34	-31.22	-30.60	-29.06	-28.90
2800	-0.23	-36.48	-36.52	11.61	-26.93	-26.54	-25.55	-25.53
2900	-0.24	-37.79	-37.66	11.82	-24.20	-23.94	-22.90	-23.07
3000	-0.26	-39.61	-39.59	11.57	-22.27	-22.22	-21.03	-21.30
3100	-0.27	-42.39	-42.50	9.86	-20.96	-20.93	-19.53	-19.74
3200	-0.29	-46.94	-46.80	5.39	-20.19	-20.21	-18.41	-18.57
3300	-0.29	-54.58	-53.96	1.18	-19.57	-19.61	-17.48	-17.54

Bi-Directional Coupler

BDCH-35-272+

Typical Performance Data

Test Conditions: Input Power = +5 dbm, Temperature = +25°C, Configuration C.

Freq. (MHz)	I. Loss (dB) In - Out	Coupling (dB)		Directivity (dB) In - Fwd	Return Loss (dB)			
		In - Fwd	Out - Rev		In	Out	Fwd	Rev
50	-0.02	-54.79	-54.79	26.11	-39.27	-39.18	-38.92	-38.69
100	-0.03	-48.86	-48.87	26.43	-34.42	-34.40	-34.39	-34.27
200	-0.05	-43.03	-43.05	26.55	-29.45	-29.12	-29.43	-29.22
300	-0.06	-39.78	-39.80	26.07	-26.74	-26.65	-26.92	-26.76
400	-0.07	-37.65	-37.67	25.32	-25.20	-25.20	-25.40	-25.33
500	-0.09	-36.17	-36.19	24.66	-24.27	-24.38	-24.67	-24.65
600	-0.10	-35.13	-35.15	24.19	-23.88	-24.05	-24.41	-24.55
700	-0.10	-34.44	-34.46	23.92	-23.89	-24.26	-24.60	-24.98
800	-0.11	-34.03	-34.04	23.77	-23.98	-24.69	-24.68	-25.63
900	-0.12	-33.88	-33.88	23.76	-23.85	-25.09	-24.36	-25.98
1000	-0.13	-33.92	-33.92	23.55	-23.40	-25.15	-23.74	-25.75
1100	-0.14	-34.15	-34.14	23.14	-22.80	-24.50	-22.84	-24.65
1200	-0.15	-34.54	-34.50	23.10	-21.97	-23.47	-21.79	-23.19
1300	-0.16	-35.04	-34.99	22.69	-21.25	-22.37	-20.92	-21.89
1350	-0.17	-35.27	-35.26	22.48	-20.98	-21.91	-20.53	-21.32
1400	-0.17	-35.51	-35.49	21.96	-20.77	-21.43	-20.25	-20.77
1450	-0.18	-35.71	-35.73	21.54	-20.58	-21.05	-19.98	-20.35
1500	-0.18	-35.91	-35.91	20.78	-20.47	-20.72	-19.80	-19.97
1550	-0.19	-36.07	-36.06	20.83	-20.39	-20.51	-19.63	-19.71
1600	-0.19	-36.12	-36.11	20.41	-20.37	-20.35	-19.60	-19.59
1650	-0.19	-36.10	-36.13	20.18	-20.45	-20.26	-19.60	-19.43
1700	-0.20	-36.04	-36.11	19.33	-20.57	-20.29	-19.65	-19.43
1750	-0.20	-35.91	-36.02	18.52	-20.81	-20.33	-19.83	-19.46
1800	-0.20	-35.77	-35.86	18.20	-21.02	-20.54	-20.02	-19.62
1850	-0.20	-35.52	-35.64	18.00	-21.47	-20.86	-20.35	-19.83
1900	-0.20	-35.30	-35.44	17.52	-21.92	-21.20	-20.67	-20.15
1950	-0.20	-35.06	-35.21	17.21	-22.52	-21.72	-21.12	-20.62
2000	-0.20	-34.83	-35.01	16.69	-23.08	-22.29	-21.67	-21.06
2100	-0.20	-34.38	-34.57	16.32	-24.87	-23.89	-23.08	-22.42
2200	-0.20	-34.04	-34.23	15.91	-27.20	-26.25	-25.00	-24.35
2300	-0.20	-33.85	-34.01	15.53	-30.64	-29.89	-27.93	-27.20
2400	-0.20	-33.86	-34.04	15.01	-36.71	-36.35	-32.42	-31.91
2500	-0.20	-34.09	-34.21	14.32	-45.83	-49.66	-43.27	-43.58
2600	-0.21	-34.55	-34.61	13.57	-34.44	-34.19	-39.28	-38.45
2700	-0.21	-35.23	-35.33	13.05	-29.06	-28.90	-31.22	-30.60
2800	-0.23	-36.48	-36.52	11.05	-25.55	-25.53	-26.93	-26.54
2900	-0.24	-37.79	-37.65	10.76	-22.90	-23.07	-24.20	-23.94
3000	-0.26	-39.61	-39.59	9.66	-21.03	-21.30	-22.27	-22.22
3100	-0.28	-42.39	-42.51	7.61	-19.53	-19.74	-20.96	-20.93
3200	-0.30	-46.94	-46.79	2.96	-18.41	-18.57	-20.19	-20.21
3300	-0.32	-54.60	-53.98	2.28	-17.48	-17.54	-19.57	-19.61

Bi-Directional Coupler

BDCH-35-272+

Typical Performance Data

Test Conditions: Input Power = +5 dbm, Temperature = +25°C, Configuration D.

Freq. (MHz)	I. Loss (dB) In - Out	Coupling (dB)		Directivity (dB) In - Fwd	Return Loss (dB)			
		In - Fwd	Out - Rev		In	Out	Fwd	Rev
50	-0.03	-54.79	-54.79	26.29	-39.18	-39.27	-38.69	-38.92
100	-0.04	-48.87	-48.86	26.56	-34.40	-34.42	-34.27	-34.39
200	-0.05	-43.05	-43.03	26.35	-29.12	-29.45	-29.22	-29.43
300	-0.07	-39.80	-39.78	26.06	-26.65	-26.74	-26.76	-26.92
400	-0.08	-37.67	-37.65	25.59	-25.20	-25.20	-25.33	-25.40
500	-0.09	-36.19	-36.17	25.06	-24.38	-24.27	-24.65	-24.67
600	-0.10	-35.15	-35.13	24.75	-24.05	-23.88	-24.55	-24.41
700	-0.11	-34.46	-34.44	24.69	-24.26	-23.89	-24.98	-24.60
800	-0.12	-34.04	-34.03	24.45	-24.69	-23.98	-25.63	-24.68
900	-0.12	-33.88	-33.88	24.52	-25.09	-23.85	-25.98	-24.36
1000	-0.13	-33.92	-33.92	24.42	-25.15	-23.40	-25.75	-23.74
1100	-0.14	-34.14	-34.15	24.07	-24.50	-22.80	-24.65	-22.84
1200	-0.16	-34.50	-34.54	23.96	-23.47	-21.97	-23.19	-21.79
1300	-0.17	-34.99	-35.04	24.00	-22.37	-21.25	-21.89	-20.92
1350	-0.17	-35.26	-35.27	23.71	-21.91	-20.98	-21.32	-20.53
1400	-0.18	-35.49	-35.51	23.15	-21.43	-20.77	-20.77	-20.25
1450	-0.18	-35.73	-35.71	22.60	-21.05	-20.58	-20.35	-19.98
1500	-0.18	-35.91	-35.91	21.73	-20.72	-20.47	-19.97	-19.80
1550	-0.19	-36.06	-36.07	21.10	-20.51	-20.39	-19.71	-19.63
1600	-0.19	-36.11	-36.12	20.80	-20.35	-20.37	-19.59	-19.60
1650	-0.20	-36.13	-36.10	20.35	-20.26	-20.45	-19.43	-19.60
1700	-0.20	-36.11	-36.04	19.58	-20.29	-20.57	-19.43	-19.65
1750	-0.20	-36.02	-35.91	18.69	-20.33	-20.81	-19.46	-19.83
1800	-0.20	-35.86	-35.77	18.43	-20.54	-21.02	-19.62	-20.02
1850	-0.20	-35.64	-35.52	18.09	-20.86	-21.47	-19.83	-20.35
1900	-0.20	-35.44	-35.30	17.16	-21.20	-21.92	-20.15	-20.67
1950	-0.20	-35.21	-35.06	16.78	-21.72	-22.52	-20.62	-21.12
2000	-0.20	-35.01	-34.83	16.39	-22.29	-23.08	-21.06	-21.67
2100	-0.19	-34.57	-34.38	16.10	-23.89	-24.87	-22.42	-23.08
2200	-0.20	-34.23	-34.04	15.62	-26.25	-27.20	-24.35	-25.00
2300	-0.20	-34.01	-33.85	15.14	-29.89	-30.64	-27.20	-27.93
2400	-0.20	-34.04	-33.86	14.85	-36.35	-36.71	-31.91	-32.42
2500	-0.20	-34.21	-34.09	14.42	-49.66	-45.83	-43.58	-43.27
2600	-0.21	-34.61	-34.55	14.01	-34.19	-34.44	-38.45	-39.28
2700	-0.22	-35.33	-35.23	13.31	-28.90	-29.06	-30.60	-31.22
2800	-0.23	-36.52	-36.48	11.62	-25.53	-25.55	-26.54	-26.93
2900	-0.24	-37.65	-37.79	12.03	-23.07	-22.90	-23.94	-24.20
3000	-0.26	-39.59	-39.61	11.66	-21.30	-21.03	-22.22	-22.27
3100	-0.28	-42.51	-42.39	9.78	-19.74	-19.53	-20.93	-20.96
3200	-0.30	-46.79	-46.94	5.53	-18.57	-18.41	-20.21	-20.19
3300	-0.32	-53.98	-54.60	1.35	-17.54	-17.48	-19.61	-19.57

Bi-Directional Coupler

BDCH-35-272+

Typical Performance Data

Test Conditions: Input Power = +5 dbm, Temperature = +105°C, Configuration A.

Freq. (MHz)	I. Loss (dB)		Coupling (dB)		Directivity (dB)	Return Loss (dB)			
	In - Out	In - Fwd	Out - Rev	In - Fwd		In	Out	Fwd	Rev
50	-0.02	-54.72	-54.72	25.42	-34.43	-34.57	-35.24	-35.36	
100	-0.03	-48.79	-48.79	27.60	-32.26	-32.32	-31.81	-31.87	
200	-0.04	-42.98	-42.96	29.96	-33.24	-33.95	-31.32	-31.74	
300	-0.05	-39.72	-39.71	28.77	-29.99	-30.38	-30.43	-30.70	
400	-0.07	-37.60	-37.58	26.51	-26.29	-26.41	-27.30	-27.37	
500	-0.08	-36.13	-36.11	25.14	-24.72	-24.73	-24.80	-24.72	
600	-0.09	-35.10	-35.08	24.62	-24.73	-24.58	-23.81	-23.70	
700	-0.09	-34.42	-34.40	24.37	-24.64	-24.34	-23.74	-23.45	
800	-0.10	-33.99	-33.98	23.72	-24.89	-24.13	-23.81	-23.36	
900	-0.11	-33.85	-33.83	23.23	-25.09	-23.84	-23.98	-23.14	
1000	-0.12	-33.87	-33.88	22.93	-25.44	-23.69	-24.31	-23.05	
1100	-0.12	-34.11	-34.10	22.21	-24.95	-23.17	-24.45	-22.94	
1200	-0.14	-34.47	-34.51	22.09	-23.69	-22.25	-23.83	-22.39	
1300	-0.15	-34.93	-34.98	21.64	-22.33	-21.31	-22.75	-21.63	
1350	-0.16	-35.06	-35.30	21.19	-21.63	-20.75	-22.33	-21.24	
1400	-0.16	-35.52	-35.51	22.73	-20.94	-20.36	-21.73	-20.96	
1450	-0.17	-35.66	-35.71	20.91	-20.38	-19.95	-21.12	-20.61	
1500	-0.17	-35.90	-35.88	20.59	-19.86	-19.59	-20.65	-20.33	
1550	-0.18	-36.08	-36.04	19.85	-19.45	-19.26	-20.30	-20.04	
1600	-0.19	-35.87	-36.32	23.27	-19.27	-19.12	-20.10	-19.83	
1650	-0.19	-36.14	-36.10	20.56	-18.97	-19.00	-19.76	-19.73	
1700	-0.20	-36.20	-35.98	18.51	-18.88	-18.93	-19.61	-19.71	
1750	-0.20	-36.08	-35.86	18.09	-18.86	-19.02	-19.60	-19.78	
1800	-0.20	-35.99	-35.83	17.01	-18.97	-19.15	-19.75	-19.88	
1850	-0.20	-35.66	-35.51	17.84	-19.22	-19.47	-20.03	-20.23	
1900	-0.20	-35.39	-35.28	17.64	-19.51	-19.77	-20.23	-20.61	
1950	-0.20	-35.16	-35.03	17.07	-20.00	-20.23	-20.75	-21.15	
2000	-0.19	-34.96	-34.83	16.13	-20.51	-20.84	-21.42	-21.73	
2100	-0.19	-34.52	-34.33	16.44	-21.98	-22.40	-22.95	-23.53	
2200	-0.19	-34.23	-34.01	15.60	-24.10	-24.57	-25.53	-26.06	
2300	-0.18	-33.98	-33.79	15.23	-27.35	-27.88	-29.43	-29.82	
2400	-0.18	-33.98	-33.84	14.78	-32.67	-33.36	-36.33	-36.86	
2500	-0.18	-34.19	-34.06	14.26	-45.46	-48.71	-46.06	-42.94	
2600	-0.19	-34.50	-34.34	12.96	-37.05	-36.87	-32.94	-32.54	
2700	-0.20	-35.39	-35.28	13.02	-30.48	-30.65	-27.87	-27.86	
2800	-0.19	-36.30	-36.32	11.77	-26.31	-26.50	-24.81	-24.60	
2900	-0.21	-37.76	-37.96	10.01	-23.87	-24.11	-22.56	-22.31	
3000	-0.23	-39.58	-39.58	9.43	-22.14	-22.18	-20.63	-20.58	
3100	-0.24	-42.08	-42.16	8.68	-20.88	-20.97	-19.21	-19.17	
3200	-0.26	-46.86	-46.84	2.16	-20.15	-20.17	-18.26	-18.15	
3300	-0.28	-51.20	-51.64	1.10	-19.48	-19.52	-17.24	-17.22	

NOTES:

- A. Performance and quality attributes and conditions not expressly stated in this specification document are intended to be excluded and do not form a part of this specification document.
 B. Electrical specifications and performance data contained in this specification document are based on Mini-Circuit's applicable established test performance criteria and measurement instructions.
 C. The parts covered by this specification document are subject to Mini-Circuits standard limited warranty and terms and conditions (collectively, "Standard Terms"); Purchasers of this part are entitled to the rights and benefits contained therein. For a full statement of the Standard Terms and the exclusive rights and remedies thereunder, please visit Mini-Circuits' website at <https://www.minicircuits.com/terms/viewterm.html>



Bi-Directional Coupler

BDCH-35-272+

Typical Performance Data

Test Conditions: Input Power = +5 dbm, Temperature = +105°C, Configuration B.

Freq. (MHz)	I. Loss (dB)		Coupling (dB)		Directivity (dB)	Return Loss (dB)			
	In - Out	In - Fwd	Out - Rev	In - Fwd		In	Out	Fwd	Rev
50	-0.02	-54.72	-54.72	26.21	-34.57	-34.43	-35.36	-35.24	
100	-0.03	-48.79	-48.79	27.91	-32.32	-32.26	-31.87	-31.81	
200	-0.04	-42.96	-42.98	30.08	-33.95	-33.24	-31.74	-31.32	
300	-0.05	-39.71	-39.72	28.65	-30.38	-29.99	-30.70	-30.43	
400	-0.07	-37.58	-37.60	26.64	-26.41	-26.29	-27.37	-27.30	
500	-0.08	-36.11	-36.13	25.28	-24.73	-24.72	-24.72	-24.80	
600	-0.09	-35.08	-35.10	24.71	-24.58	-24.73	-23.70	-23.81	
700	-0.09	-34.40	-34.42	24.25	-24.34	-24.64	-23.45	-23.74	
800	-0.10	-33.98	-33.99	23.72	-24.13	-24.89	-23.36	-23.81	
900	-0.11	-33.83	-33.85	23.43	-23.84	-25.09	-23.14	-23.98	
1000	-0.12	-33.88	-33.87	23.17	-23.69	-25.44	-23.05	-24.31	
1100	-0.12	-34.10	-34.11	22.62	-23.17	-24.95	-22.94	-24.45	
1200	-0.14	-34.51	-34.47	22.90	-22.25	-23.69	-22.39	-23.83	
1300	-0.15	-34.98	-34.93	22.51	-21.31	-22.33	-21.63	-22.75	
1350	-0.16	-35.30	-35.06	21.73	-20.75	-21.63	-21.24	-22.33	
1400	-0.16	-35.51	-35.52	23.44	-20.36	-20.94	-20.96	-21.73	
1450	-0.17	-35.71	-35.66	22.12	-19.95	-20.38	-20.61	-21.12	
1500	-0.18	-35.88	-35.90	22.02	-19.59	-19.86	-20.33	-20.65	
1550	-0.19	-36.04	-36.08	20.26	-19.26	-19.45	-20.04	-20.30	
1600	-0.20	-36.32	-35.87	23.48	-19.12	-19.27	-19.83	-20.10	
1650	-0.20	-36.10	-36.14	19.70	-19.00	-18.97	-19.73	-19.76	
1700	-0.20	-35.98	-36.20	19.20	-18.93	-18.88	-19.71	-19.61	
1750	-0.20	-35.86	-36.08	18.58	-19.02	-18.86	-19.78	-19.60	
1800	-0.21	-35.83	-35.99	17.47	-19.15	-18.97	-19.88	-19.75	
1850	-0.20	-35.51	-35.66	17.56	-19.47	-19.22	-20.23	-20.03	
1900	-0.21	-35.28	-35.39	17.21	-19.77	-19.51	-20.61	-20.23	
1950	-0.20	-35.03	-35.16	16.55	-20.23	-20.00	-21.15	-20.75	
2000	-0.20	-34.83	-34.96	15.90	-20.84	-20.51	-21.73	-21.42	
2100	-0.19	-34.33	-34.52	15.84	-22.40	-21.98	-23.53	-22.95	
2200	-0.19	-34.01	-34.23	15.29	-24.57	-24.10	-26.06	-25.53	
2300	-0.18	-33.79	-33.98	14.82	-27.88	-27.35	-29.82	-29.43	
2400	-0.18	-33.84	-33.98	14.32	-33.36	-32.67	-36.86	-36.33	
2500	-0.19	-34.06	-34.19	14.14	-48.71	-45.46	-42.94	-46.06	
2600	-0.20	-34.34	-34.50	13.65	-36.87	-37.05	-32.54	-32.94	
2700	-0.21	-35.28	-35.39	12.95	-30.65	-30.48	-27.86	-27.87	
2800	-0.20	-36.32	-36.30	12.61	-26.50	-26.31	-24.60	-24.81	
2900	-0.22	-37.96	-37.76	10.45	-24.11	-23.87	-22.31	-22.56	
3000	-0.24	-39.58	-39.58	11.58	-22.18	-22.14	-20.58	-20.63	
3100	-0.24	-42.16	-42.08	10.85	-20.97	-20.88	-19.17	-19.21	
3200	-0.26	-46.84	-46.86	4.30	-20.17	-20.15	-18.15	-18.26	
3300	-0.28	-51.64	-51.20	1.96	-19.52	-19.48	-17.22	-17.24	

NOTES:

- A. Performance and quality attributes and conditions not expressly stated in this specification document are intended to be excluded and do not form a part of this specification document.
 B. Electrical specifications and performance data contained in this specification document are based on Mini-Circuit's applicable established test performance criteria and measurement instructions.
 C. The parts covered by this specification document are subject to Mini-Circuits standard limited warranty and terms and conditions (collectively, "Standard Terms"); Purchasers of this part are entitled to the rights and benefits contained therein. For a full statement of the Standard Terms and the exclusive rights and remedies thereunder, please visit Mini-Circuits' website at <https://www.minicircuits.com/terms/viewterm.html>



Bi-Directional Coupler

BDCH-35-272+

Typical Performance Data

Test Conditions: Input Power = +5 dbm, Temperature = +105°C, Configuration C.

Freq. (MHz)	I. Loss (dB) In - Out	Coupling (dB)		Directivity (dB) In - Fwd	Return Loss (dB)			
		In - Fwd	Out - Rev		In	Out	Fwd	Rev
50	-0.02	-54.72	-54.73	25.86	-35.36	-35.24	-34.57	-34.43
100	-0.03	-48.78	-48.80	27.81	-31.87	-31.81	-32.32	-32.26
200	-0.04	-42.96	-42.97	30.04	-31.74	-31.32	-33.95	-33.24
300	-0.05	-39.71	-39.72	28.95	-30.70	-30.43	-30.38	-29.99
400	-0.06	-37.58	-37.60	26.46	-27.37	-27.30	-26.41	-26.29
500	-0.08	-36.11	-36.13	24.94	-24.72	-24.80	-24.73	-24.72
600	-0.09	-35.08	-35.11	24.39	-23.70	-23.81	-24.58	-24.73
700	-0.10	-34.39	-34.42	24.11	-23.45	-23.74	-24.34	-24.64
800	-0.10	-33.97	-34.00	23.45	-23.36	-23.81	-24.13	-24.89
900	-0.11	-33.83	-33.85	22.94	-23.14	-23.98	-23.84	-25.09
1000	-0.12	-33.88	-33.88	22.73	-23.05	-24.31	-23.69	-25.44
1100	-0.12	-34.09	-34.12	22.02	-22.94	-24.45	-23.17	-24.95
1200	-0.14	-34.50	-34.48	22.05	-22.39	-23.83	-22.25	-23.69
1300	-0.15	-34.98	-34.94	21.57	-21.63	-22.75	-21.31	-22.33
1350	-0.16	-35.30	-35.06	20.87	-21.24	-22.33	-20.75	-21.63
1400	-0.16	-35.51	-35.53	22.88	-20.96	-21.73	-20.36	-20.94
1450	-0.17	-35.70	-35.67	20.87	-20.61	-21.12	-19.95	-20.38
1500	-0.17	-35.87	-35.90	20.67	-20.33	-20.65	-19.59	-19.86
1550	-0.18	-36.04	-36.09	19.92	-20.04	-20.30	-19.26	-19.45
1600	-0.19	-36.31	-35.86	22.73	-19.83	-20.10	-19.12	-19.27
1650	-0.19	-36.10	-36.14	20.66	-19.73	-19.76	-19.00	-18.97
1700	-0.19	-35.97	-36.21	18.77	-19.71	-19.61	-18.93	-18.88
1750	-0.19	-35.85	-36.09	18.26	-19.78	-19.60	-19.02	-18.86
1800	-0.20	-35.82	-36.00	17.15	-19.88	-19.75	-19.15	-18.97
1850	-0.19	-35.51	-35.67	17.87	-20.23	-20.03	-19.47	-19.22
1900	-0.20	-35.27	-35.40	17.65	-20.61	-20.23	-19.77	-19.51
1950	-0.19	-35.02	-35.17	17.00	-21.15	-20.75	-20.23	-20.00
2000	-0.19	-34.82	-34.97	16.17	-21.73	-21.42	-20.84	-20.51
2100	-0.18	-34.32	-34.53	16.36	-23.53	-22.95	-22.40	-21.98
2200	-0.18	-34.00	-34.24	15.63	-26.06	-25.53	-24.57	-24.10
2300	-0.18	-33.79	-33.99	15.17	-29.82	-29.43	-27.88	-27.35
2400	-0.18	-33.83	-33.99	14.71	-36.86	-36.33	-33.36	-32.67
2500	-0.18	-34.05	-34.20	14.23	-42.94	-46.06	-48.71	-45.46
2600	-0.19	-34.34	-34.51	13.03	-32.54	-32.94	-36.87	-37.05
2700	-0.20	-35.27	-35.40	13.08	-27.86	-27.87	-30.65	-30.48
2800	-0.20	-36.31	-36.31	11.72	-24.60	-24.81	-26.50	-26.31
2900	-0.22	-37.95	-37.77	9.79	-22.31	-22.56	-24.11	-23.87
3000	-0.25	-39.57	-39.58	9.40	-20.58	-20.63	-22.18	-22.14
3100	-0.26	-42.16	-42.08	8.61	-19.17	-19.21	-20.97	-20.88
3200	-0.29	-46.84	-46.85	2.16	-18.15	-18.26	-20.17	-20.15
3300	-0.32	-51.66	-51.22	1.54	-17.22	-17.24	-19.52	-19.48

NOTES:

- A. Performance and quality attributes and conditions not expressly stated in this specification document are intended to be excluded and do not form a part of this specification document.
 B. Electrical specifications and performance data contained in this specification document are based on Mini-Circuit's applicable established test performance criteria and measurement instructions.
 C. The parts covered by this specification document are subject to Mini-Circuits standard limited warranty and terms and conditions (collectively, "Standard Terms"); Purchasers of this part are entitled to the rights and benefits contained therein. For a full statement of the Standard Terms and the exclusive rights and remedies thereunder, please visit Mini-Circuits' website at <https://www.minicircuits.com/terms/viewterm.html>



Bi-Directional Coupler

BDCH-35-272+

Typical Performance Data

Test Conditions: Input Power = +5 dbm, Temperature = +105°C, Configuration D.

Freq. (MHz)	I. Loss (dB) In - Out	Coupling (dB)		Directivity (dB) In - Fwd	Return Loss (dB)			
		In - Fwd	Out - Rev		In	Out	Fwd	Rev
50	-0.02	-54.73	-54.72	26.10	-35.24	-35.36	-34.43	-34.57
100	-0.03	-48.80	-48.78	27.81	-31.81	-31.87	-32.26	-32.32
200	-0.04	-42.97	-42.96	30.05	-31.32	-31.74	-33.24	-33.95
300	-0.05	-39.72	-39.71	28.70	-30.43	-30.70	-29.99	-30.38
400	-0.06	-37.60	-37.58	26.73	-27.30	-27.37	-26.29	-26.41
500	-0.08	-36.13	-36.11	25.43	-24.80	-24.72	-24.72	-24.73
600	-0.09	-35.11	-35.08	25.01	-23.81	-23.70	-24.73	-24.58
700	-0.10	-34.42	-34.39	24.54	-23.74	-23.45	-24.64	-24.34
800	-0.11	-34.00	-33.97	24.00	-23.81	-23.36	-24.89	-24.13
900	-0.12	-33.85	-33.83	23.76	-23.98	-23.14	-25.09	-23.84
1000	-0.12	-33.88	-33.88	23.41	-24.31	-23.05	-25.44	-23.69
1100	-0.13	-34.12	-34.09	22.81	-24.45	-22.94	-24.95	-23.17
1200	-0.14	-34.48	-34.50	22.86	-23.83	-22.39	-23.69	-22.25
1300	-0.15	-34.94	-34.98	22.51	-22.75	-21.63	-22.33	-21.31
1350	-0.16	-35.06	-35.30	21.88	-22.33	-21.24	-21.63	-20.75
1400	-0.16	-35.53	-35.51	23.28	-21.73	-20.96	-20.94	-20.36
1450	-0.17	-35.67	-35.70	22.02	-21.12	-20.61	-20.38	-19.95
1500	-0.17	-35.90	-35.87	21.89	-20.65	-20.33	-19.86	-19.59
1550	-0.18	-36.09	-36.04	20.18	-20.30	-20.04	-19.45	-19.26
1600	-0.19	-35.86	-36.31	23.80	-20.10	-19.83	-19.27	-19.12
1650	-0.19	-36.14	-36.10	19.60	-19.76	-19.73	-18.97	-19.00
1700	-0.20	-36.21	-35.97	18.89	-19.61	-19.71	-18.88	-18.93
1750	-0.20	-36.09	-35.85	18.31	-19.60	-19.78	-18.86	-19.02
1800	-0.20	-36.00	-35.82	17.30	-19.75	-19.88	-18.97	-19.15
1850	-0.19	-35.67	-35.51	17.44	-20.03	-20.23	-19.22	-19.47
1900	-0.20	-35.40	-35.27	17.09	-20.23	-20.61	-19.51	-19.77
1950	-0.19	-35.17	-35.02	16.51	-20.75	-21.15	-20.00	-20.23
2000	-0.19	-34.97	-34.82	15.83	-21.42	-21.73	-20.51	-20.84
2100	-0.18	-34.53	-34.32	15.80	-22.95	-23.53	-21.98	-22.40
2200	-0.18	-34.24	-34.00	15.23	-25.53	-26.06	-24.10	-24.57
2300	-0.18	-33.99	-33.79	14.84	-29.43	-29.82	-27.35	-27.88
2400	-0.18	-33.99	-33.83	14.34	-36.33	-36.86	-32.67	-33.36
2500	-0.19	-34.20	-34.05	14.14	-46.06	-42.94	-45.46	-48.71
2600	-0.19	-34.51	-34.34	13.60	-32.94	-32.54	-37.05	-36.87
2700	-0.21	-35.40	-35.27	12.89	-27.87	-27.86	-30.48	-30.65
2800	-0.20	-36.31	-36.31	12.72	-24.81	-24.60	-26.31	-26.50
2900	-0.22	-37.77	-37.95	10.69	-22.56	-22.31	-23.87	-24.11
3000	-0.25	-39.58	-39.57	11.62	-20.63	-20.58	-22.14	-22.18
3100	-0.26	-42.08	-42.16	10.96	-19.21	-19.17	-20.88	-20.97
3200	-0.29	-46.85	-46.84	4.30	-18.26	-18.15	-20.15	-20.17
3300	-0.32	-51.22	-51.66	2.40	-17.24	-17.22	-19.48	-19.52

NOTES:

- A. Performance and quality attributes and conditions not expressly stated in this specification document are intended to be excluded and do not form a part of this specification document.
- B. Electrical specifications and performance data contained in this specification document are based on Mini-Circuit's applicable established test performance criteria and measurement instructions.
- C. The parts covered by this specification document are subject to Mini-Circuits standard limited warranty and terms and conditions (collectively, "Standard Terms"); Purchasers of this part are entitled to the rights and benefits contained therein. For a full statement of the Standard Terms and the exclusive rights and remedies thereunder, please visit Mini-Circuits' website at <https://www.minicircuits.com/terms/viewterm.html>



Bi-Directional Coupler

BDCH-35-272+

Typical Performance Graphs

Test Conditions: Input Power = +5 dbm, Configuration A.

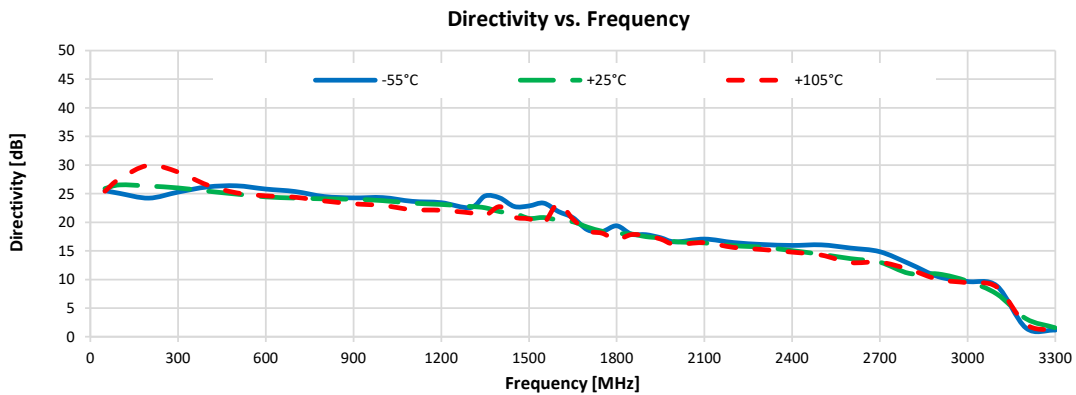
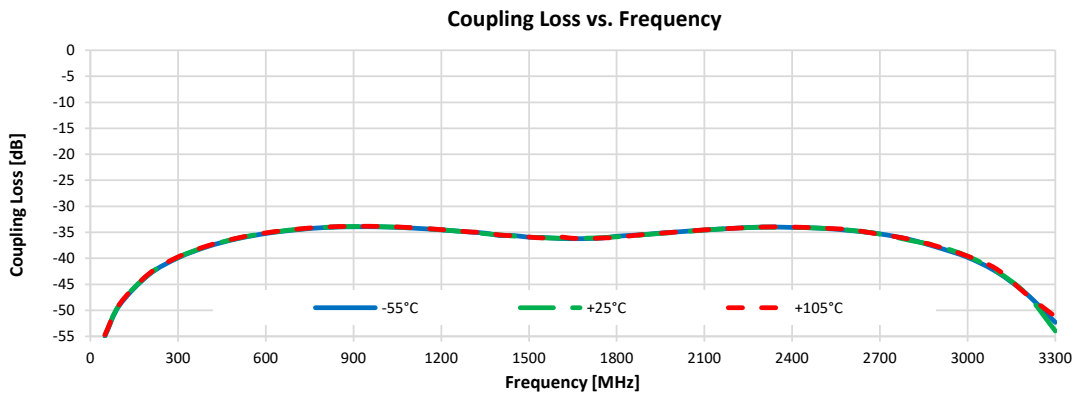
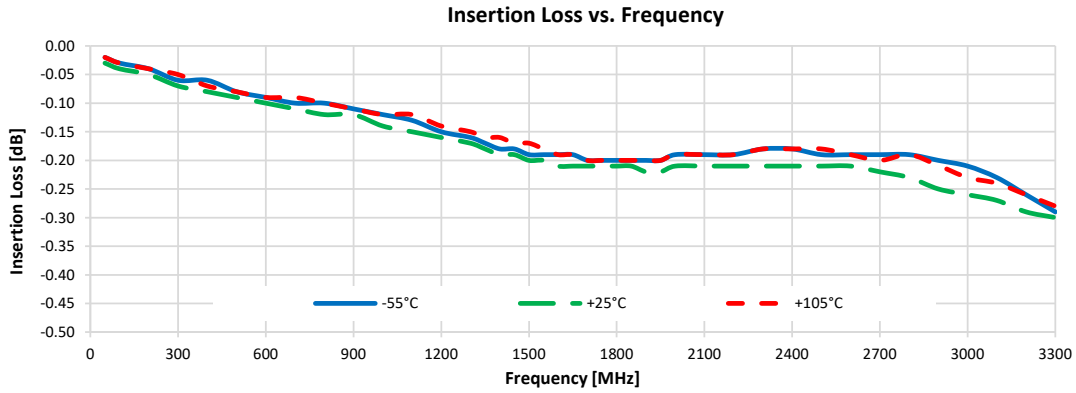

Typical Performance Graphs

Test Conditions: Input Power = +5 dbm, Configuration B.

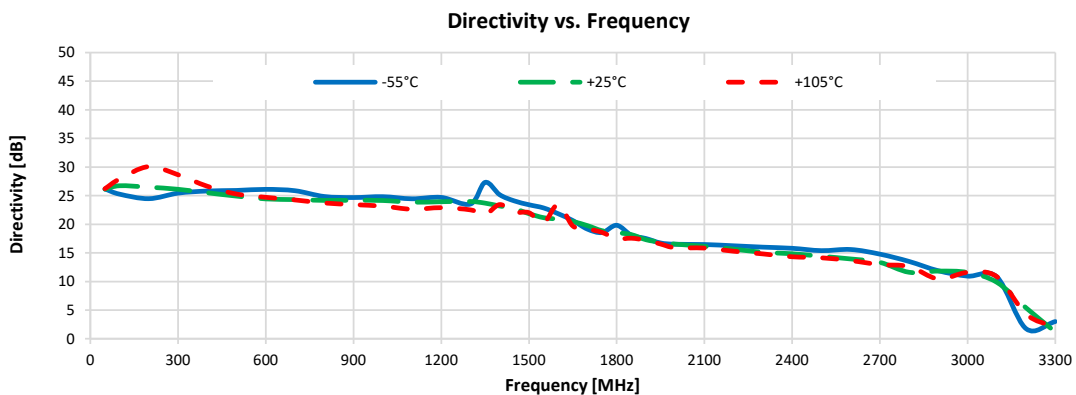
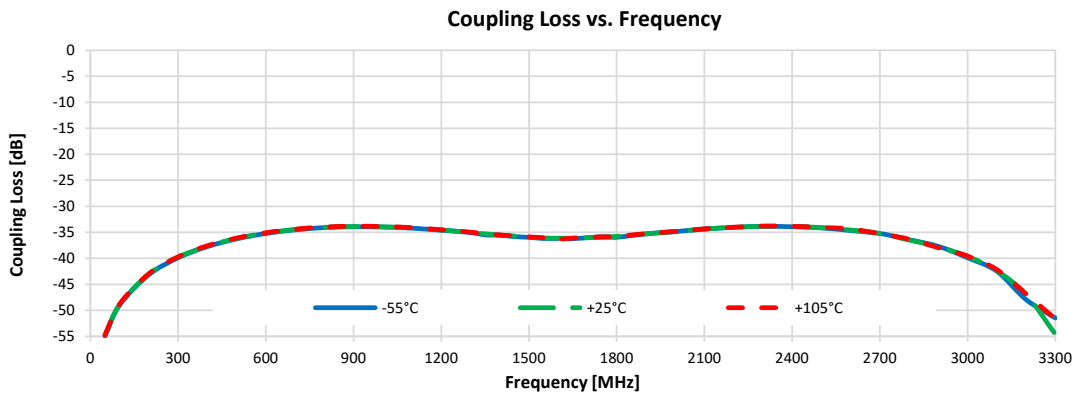
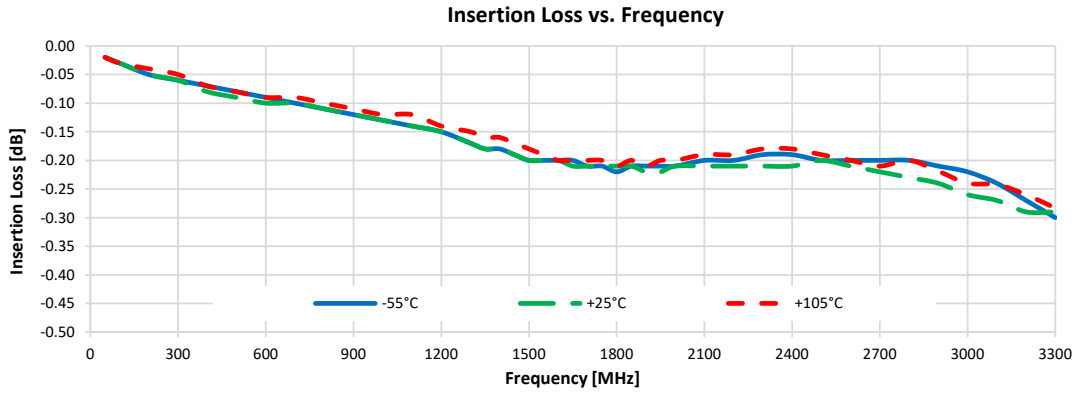

Bi-Directional Coupler

BDCH-35-272+

Typical Performance Graphs

Test Conditions: Input Power = +5 dbm, Configuration C.

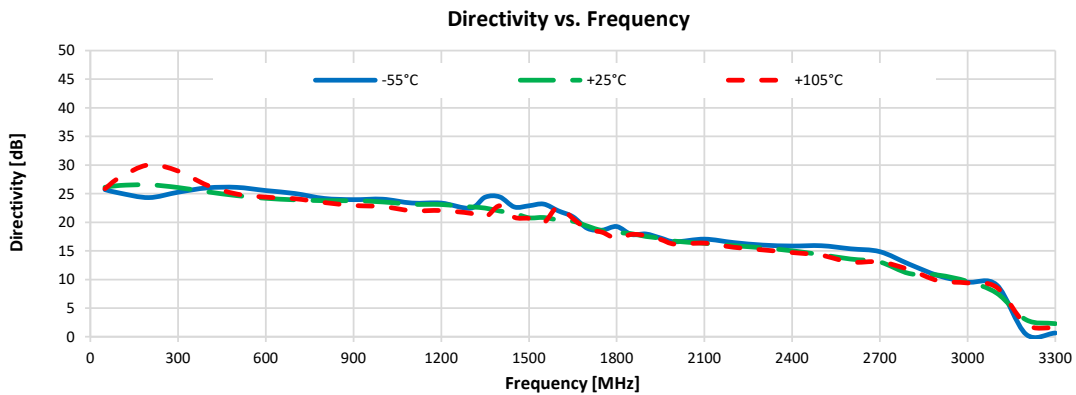
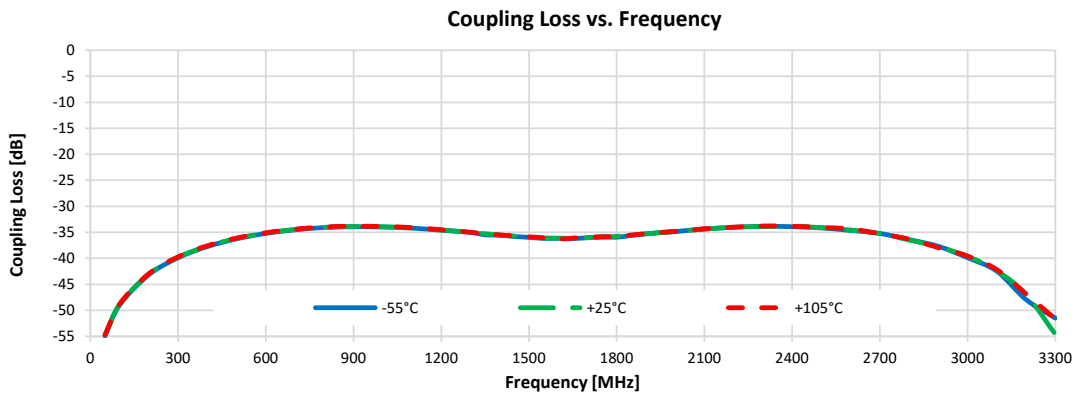
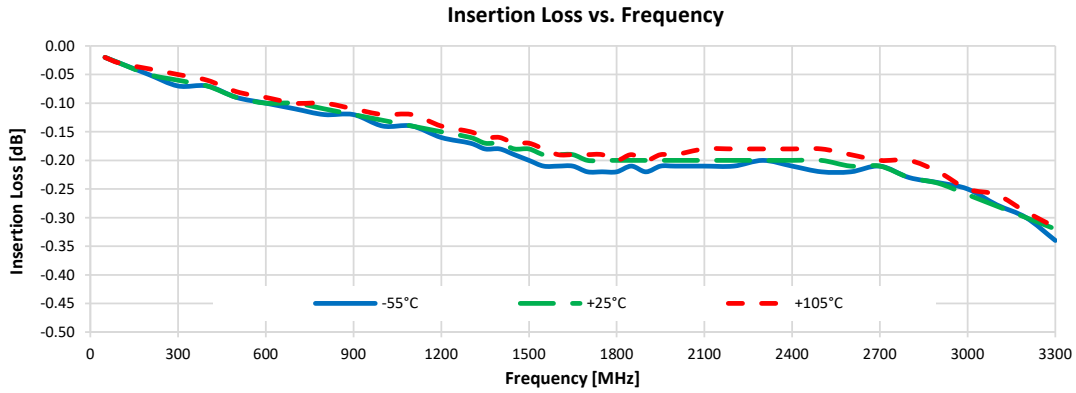

Bi-Directional Coupler

BDCH-35-272+

Typical Performance Graphs

Test Conditions: Input Power = +5 dbm, Configuration D.

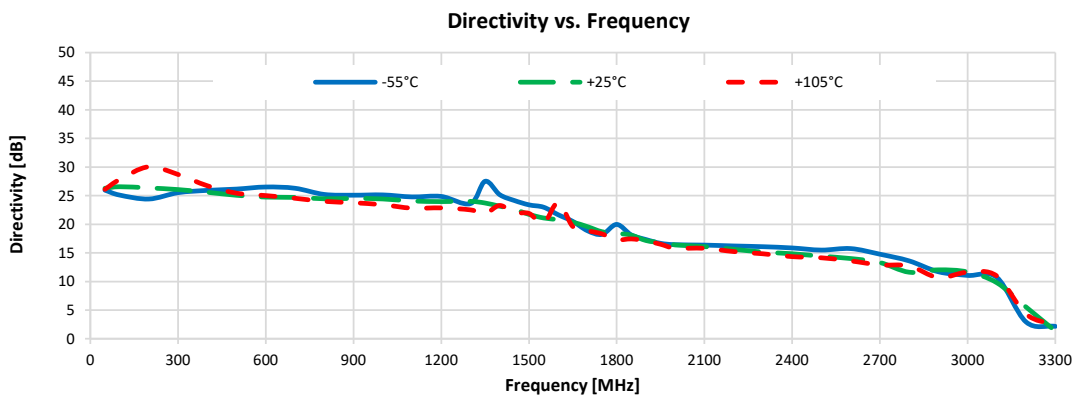
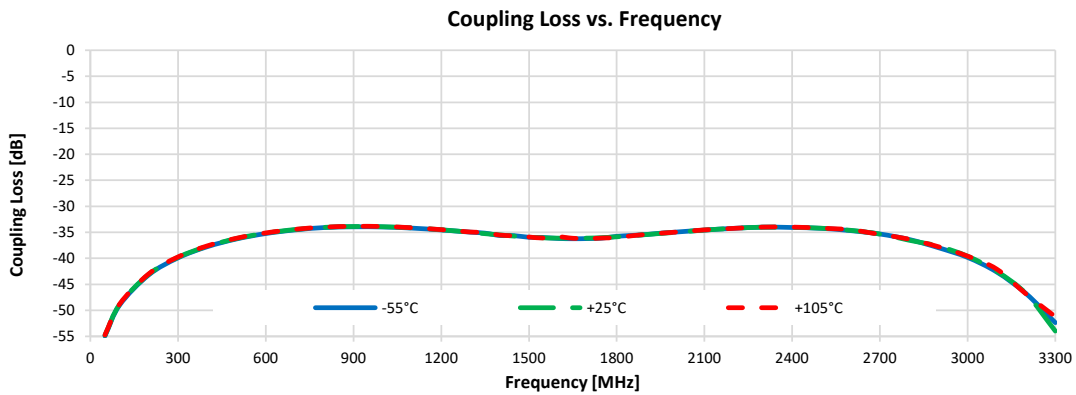
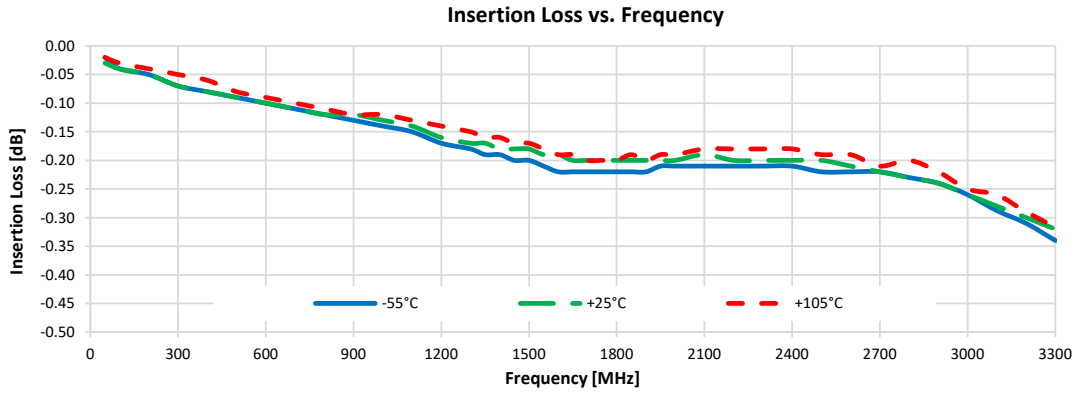

Typical Performance Graphs

Test Conditions: Input Power = +5 dbm, Configuration A.

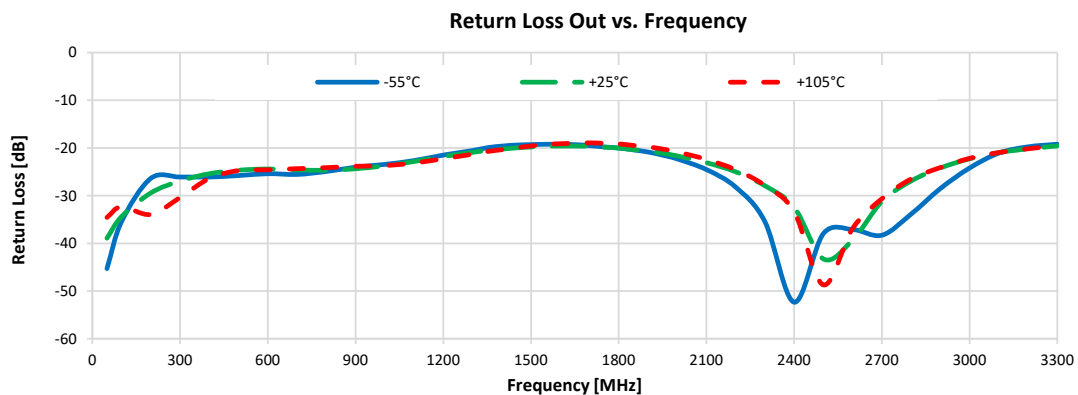
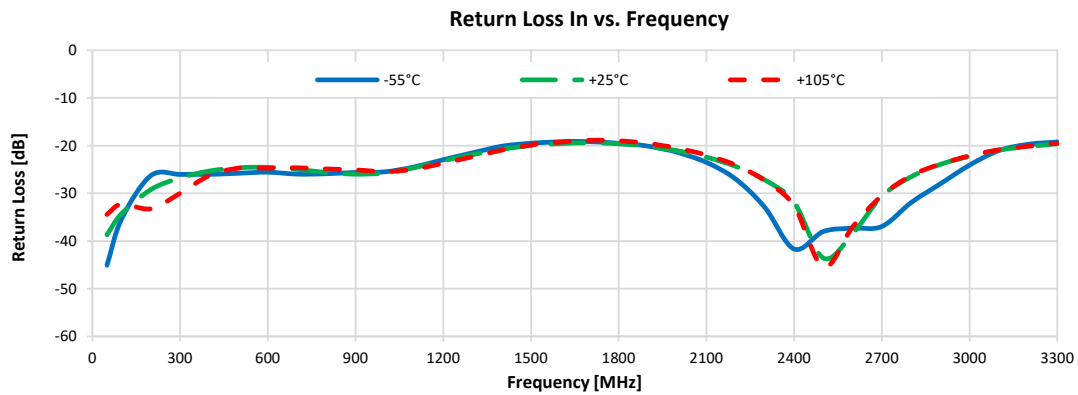
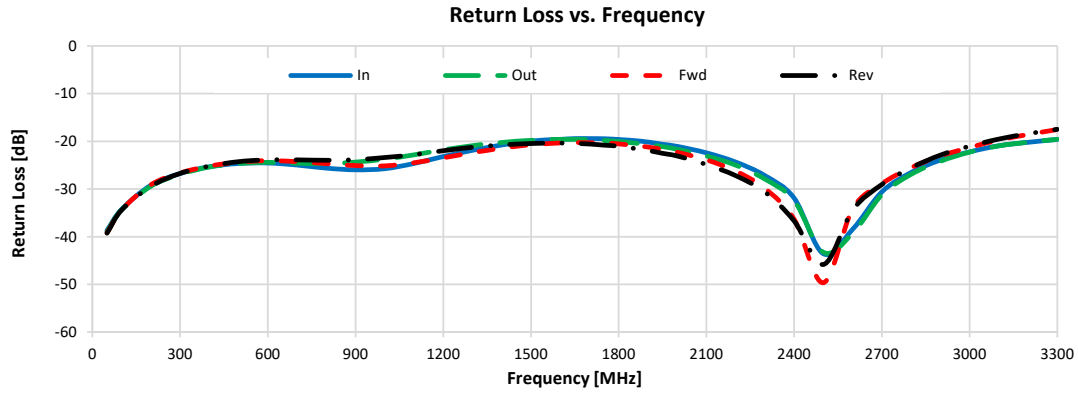

NOTES:

- A. Performance and quality attributes and conditions not expressly stated in this specification document are intended to be excluded and do not form a part of this specification document.
- B. Electrical specifications and performance data contained in this specification document are based on Mini-Circuit's applicable established test performance criteria and measurement instructions.
- C. The parts covered by this specification document are subject to Mini-Circuits standard limited warranty and terms and conditions (collectively, "Standard Terms"); Purchasers of this part are entitled to the rights and benefits contained therein. For a full statement of the Standard Terms and the exclusive rights and remedies thereunder, please visit Mini-Circuits' website at <https://www.minicircuits.com/terms/viewterm.html>



Typical Performance Graphs

Test Conditions: Input Power = +5 dbm, Configuration A.

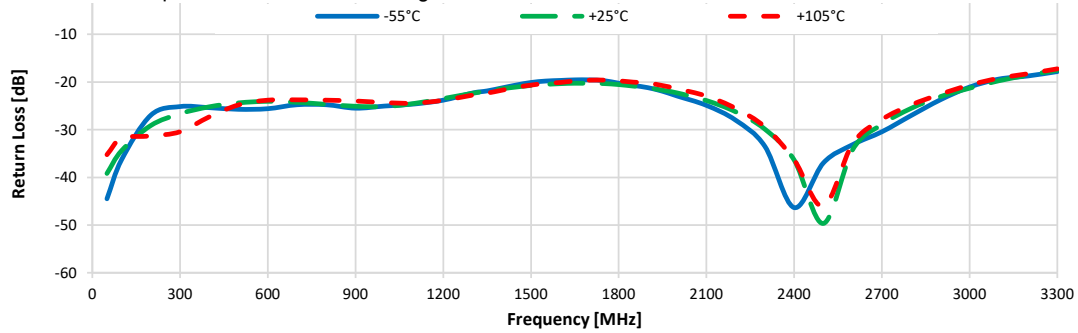

Return Loss Reverse vs. Frequency

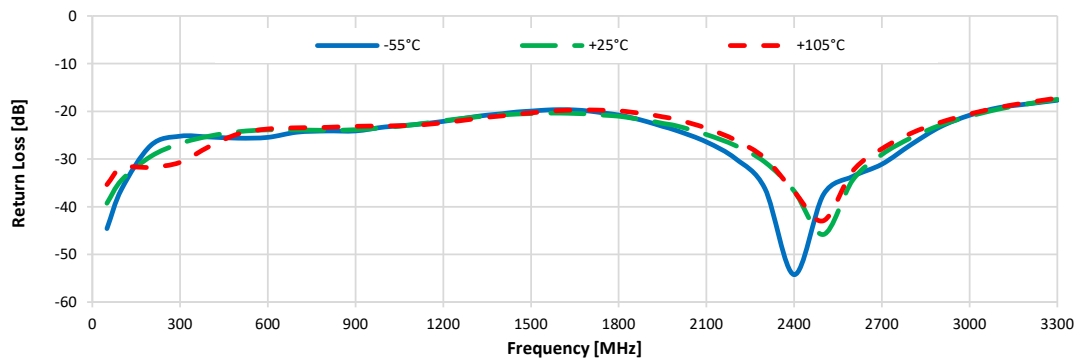

NOTES:

- A. Performance and quality attributes and conditions not expressly stated in this specification document are intended to be excluded and do not form a part of this specification document.
- B. Electrical specifications and performance data contained in this specification document are based on Mini-Circuit's applicable established test performance criteria and measurement instructions.
- C. The parts covered by this specification document are subject to Mini-Circuits standard limited warranty and terms and conditions (collectively, "Standard Terms"); Purchasers of this part are entitled to the rights and benefits contained therein. For a full statement of the Standard Terms and the exclusive rights and remedies thereunder, please visit Mini-Circuits' website at <https://www.minicircuits.com/terms/viewterm.html>



Case Style

PQ

Outline Dimensions

PQ2098

TOP SIDE

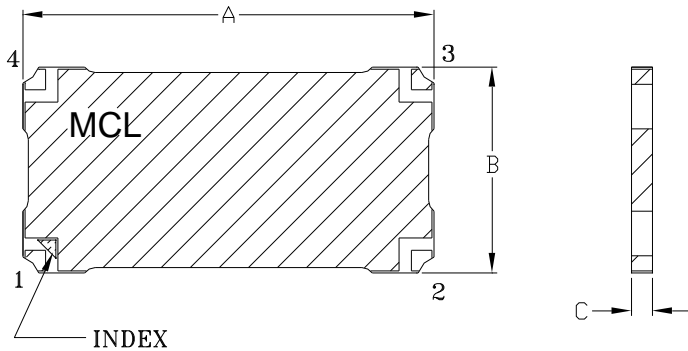

PCB LAND PATTERN

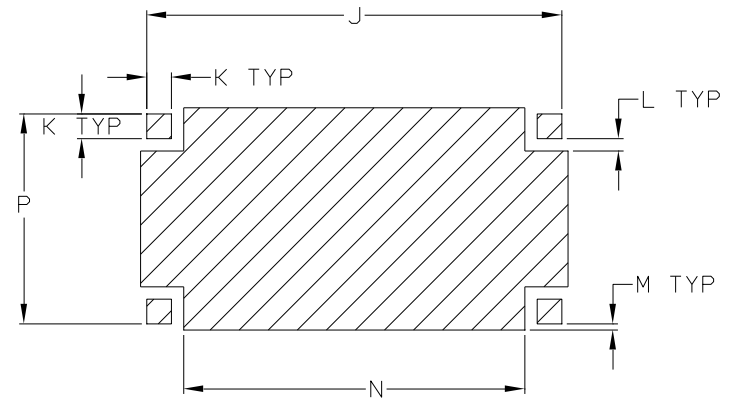

BOTTOM SIDE

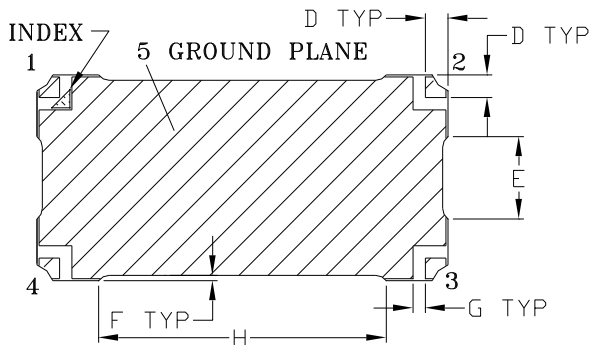

 METALLIZATION  SOLDER RESIST

CASE#	A	B	C	D	E	F	G	H	J	K	L	M	N	P	WT. GRAMS
PQ2098	1.000 (25.40)	.500 (12.70)	.051 (1.30)	.055 (1.40)	.200 (5.08)	.013 (0.33)	.030 (0.76)	.700 (17.78)	1.010 (25.65)	.060 (1.52)	.030 (0.76)	.015 (0.38)	.830 (21.08)	.510 (12.95)	2.0

Dimensions are in inches (mm). Tolerances: 2PL. +/- .03; 3PL. +/- .010

Notes:

1. Base material: Printed wiring laminate.
2. Termination finish:
For RoHS Cases, all models (+) suffix: 2-5 μ inch (.05-.13 microns) Immersion Gold.
For RoHS-5 Cases, all models no (+) suffix: Tin-Lead plate.

 **Mini-Circuits**[®]

INTERNET <http://www.minicircuits.com>

P.O. Box 350166, Brooklyn, New York 11235-0003 (718) 934-4500 Fax (718) 332-4661

Distribution Centers NORTH AMERICA 800-654-7949 • 417-335-5935 • Fax 417-335-5945 • EUROPE 44-1252-832600 • Fax 44-1252-837010

Mini-Circuits ISO 9001 & ISO 14001 Certified

Tape & Reel Packaging TR-F118

DEVICE ORIENTATION IN T&R

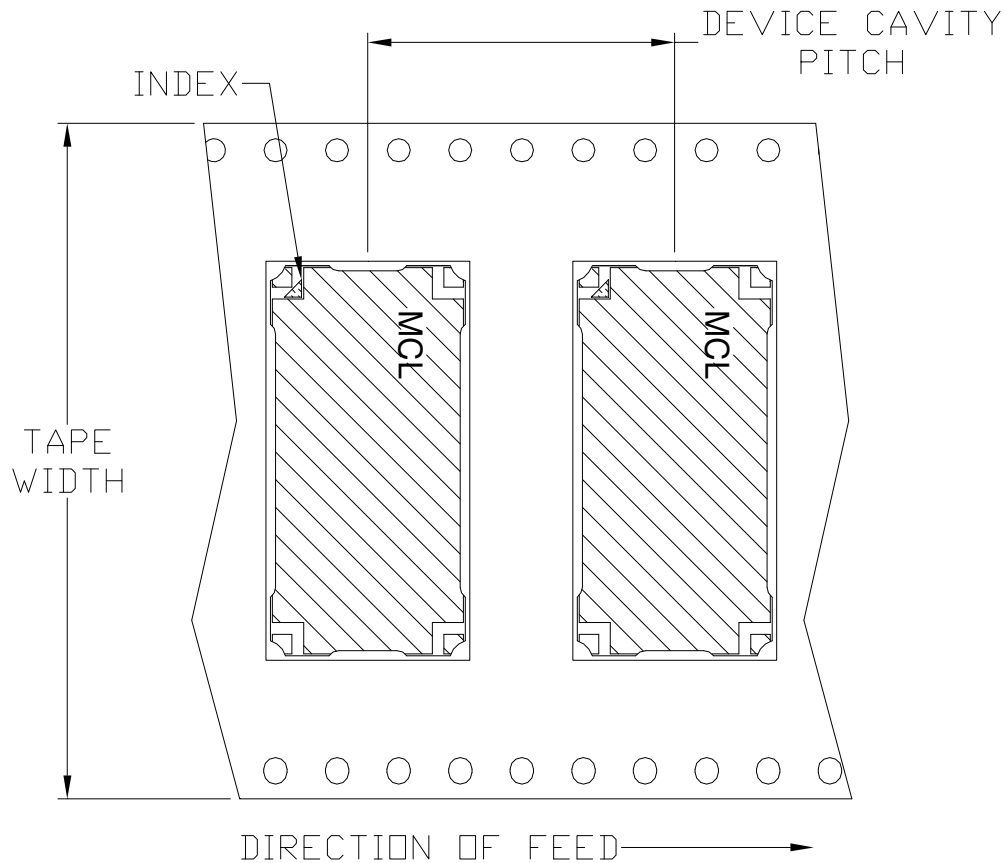

Tape Width, mm	Device Cavity Pitch, mm	Reel Size, inches	Devices per Reel
44	20	13	500

Mini-Circuits carrier tape materials provide protection from ESD (Electro-Static Discharge) during handling and transportation. Tapes are static dissipative and comply with industry standards EIA-481/EIA-541.

Go to: www.minicircuits.com/pages/pdfs/tape.pdf

 **Mini-Circuits**[®]

INTERNET <http://www.minicircuits.com>

P.O. Box 350166, Brooklyn, New York 11235-0003 (718) 934-4500 Fax (718) 332-4661

Distribution Centers NORTH AMERICA 800-654-7949 • 417-335-5935 • Fax 417-335-5945 • EUROPE 44-1252-832600 • Fax 44-1252-837010

Mini-Circuits ISO 9001 & ISO 14001 Certified

THIRD ANGLE PROJECTION

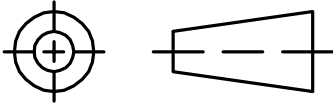

REVISIONS

REV	ECN No.	DESCRIPTION	DATE	DR	AUTH
OR	M165053	NEW RELEASE	12/17	DK	HH
OR	R92774	NEW RELEASE	12/17	DK	HH

SUGGESTED MOUNTING CONFIGURATION

FOR PQ2098 /2098-1/2098-2 CASE STYLES 04DC01 PIN CONNECTION, 50 OHM

TRACE TUNING
4 PL.
(SEE BELOW)

PACKAGE
OUTLINE

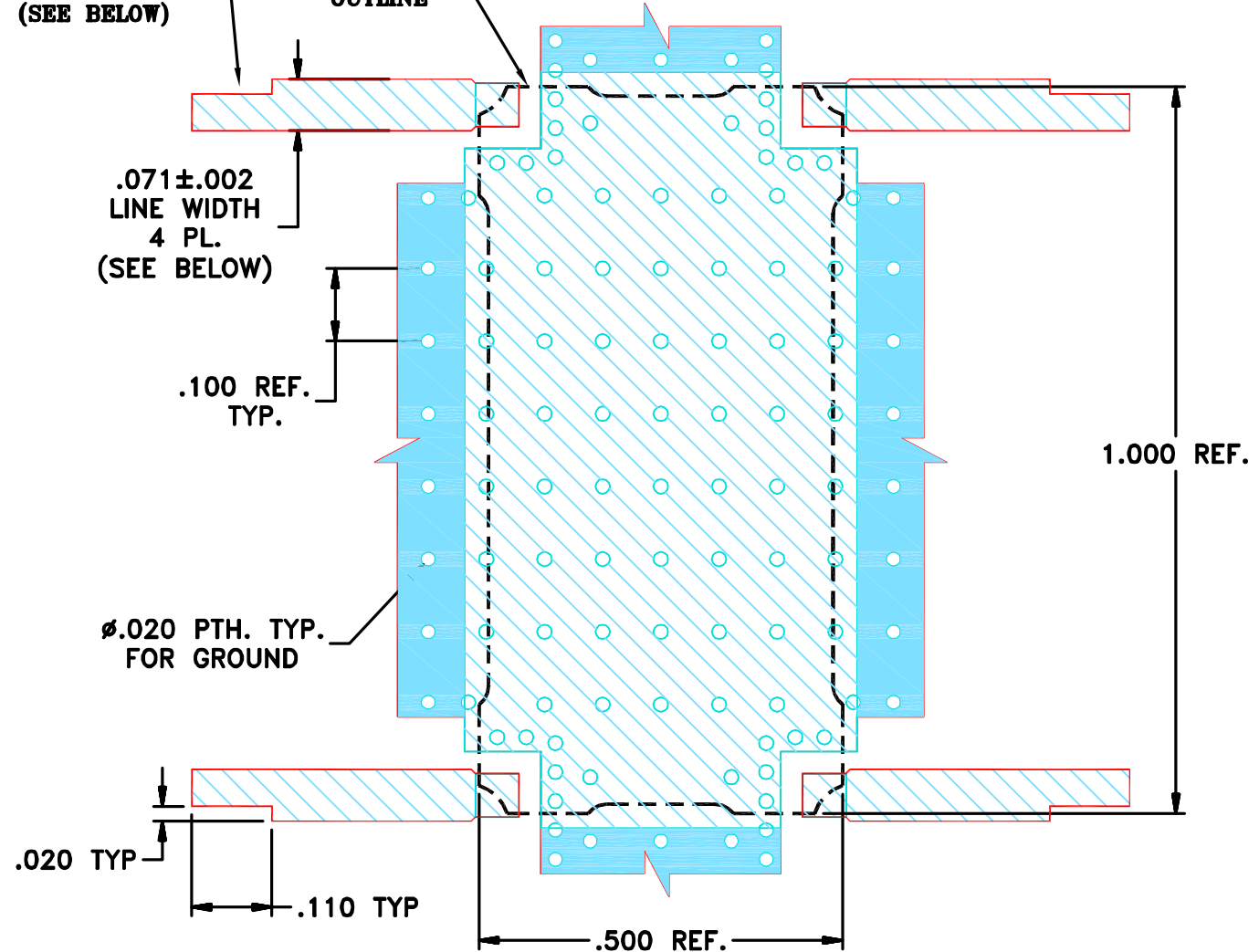

NOTES:

- TRACE WIDTH IS SHOWN FOR ROGERS R04003C WITH DIELECTRIC THICKNESS. 0.032"±.0015". COPPER: 1 OZ. EACH SIDE. FOR OTHER MATERIALS TRACE WIDTH MAY NEED TO BE MODIFIED.
- BOTTOM SIDE OF THE PCB IS CONTINUOUS GROUND PLANE.
- TRACE TUNING IN RF LINES MAY BE NEEDED TO ACHIEVE SPECIFIED PERFORMANCE.

DENOTES PCB COPPER LAYOUT WITH SMOBC (SOLDER MASK OVER BARE COPPER)

DENOTES COPPER LAND PATTERN FREE OF SOLDERMASK

UNLESS OTHERWISE SPECIFIED

INITIALS

DATE

DIMENSIONS ARE IN INCHES

DRAWN	DK (RAYON)	03 DEC 17
-------	------------	-----------

TOLERANCES ON:

CHECKED	RM (RAYON)	03 DEC 17
---------	------------	-----------

2 PL DECIMALS ±

APPROVED	HH (RAYON)	03 DEC 17
----------	------------	-----------

3 PL DECIMALS ± .005

ANGLES ± 1°

FRACTIONS ±



Mini-Circuits®

13 Neptune Avenue
Brooklyn NY 11235

PL FOR MBD PQ2098
TB-863-1 (50Ω)

Mini-Circuits®
THIS DOCUMENT AND ITS CONTENTS ARE THE PROPERTY OF MINI-CIRCUITS. EXCEPT FOR USE EXPRESSLY GRANTED, IN WRITING, TO ITS VENDORS, VENDEE AND THE UNITED STATES GOVERNMENT, MINI-CIRCUITS RESERVES ALL PROPRIETARY DESIGN, USE, MANUFACTURING AND REPRODUCTION RIGHTS THERE TO. THESE CONTENTS SHALL NOT BE USED, DUPLICATED OR DISCLOSED TO ANY OUTSIDE PARTY, IN WHOLE OR IN PART, WITHOUT WRITTEN PERMISSION OF MINI-CIRCUITS.

SIZE A	CODE IDENT 15542	DRAWING NO: 98-PL-538	REV: OR
-----------	---------------------	--------------------------	------------

ASHEETA1.DWG REV:A DATE:01/12/95

FILE:98PL538(OR) SCALE: 4:1 SHEET: 1 OF 1



All Mini-Circuits products are manufactured under exacting quality assurance and control standards, and are capable of meeting published specifications after being subjected to any or all of the following physical and environmental test.

Specification	Test/Inspection Condition	Reference/Spec
Operating Temperature	-55° to 105° C Case Environment	Individual Model Data Sheet
Storage Temperature	-55° to 105°C Ambient Environment	Individual Model Data Sheet
Humidity	90 to 95% RH, 240 hours, 50°C	MIL-STD-202, Method 103, Condition A, Except 50°C and end-point electrical test done within 12 hours
Thermal Shock	-55° to 100°C, 100 cycles	MIL-STD-202, Method 107, Condition A-3, except +100°C
Solder Reflow Heat	Sn-Pb Eutectic Process 225°C peak Pb-Free Process 245° - 250°C peak	J-STD-020C, Table 4-1, 4-2 and 5-2, Figure 5-1
Solderability	10X Magnification	J-STD-002, Para 4.2.5, Test S, 95% Coverage
Vibration (high Frequency)	20g peak, 10-2000 Hz, 12 times in each of three perpendicular directions (total 36)	MIL-STD-883, Method 2007.3, Condition A
Mechanical Shock	50g, 11 ms, 1/2-sine, 18 shocks: 3 each direction, each of 3 axes	MIL-STD-202, Method 213, Condition A
Marking Resistance to Solvents	Isopropyl alcohol + mineral spirits at 25°C; terpene defluxer at 25°C; distilled water + proylene glycol monomethyl ether + monoethanolamine at 63°C to 70°C	MIL-STD-202, Method 215