



STRIPLINE SURFACE MOUNT

Bi-Directional Coupler

BDCH-20-63A+

50Ω 2000 to 6000 MHz 20 dB 140W

KEY FEATURES

- High power handling, up to 140W
- Ultra wideband, 2000 to 6000 MHz
- Low insertion loss, 0.15 dB

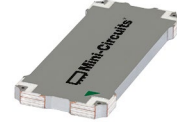

Generic photo used for illustration purposes only

APPLICATIONS

- Power amplifiers
- Antenna feeds
- Mobile satellite communication
- Digital communication applications

FUNCTIONAL DIAGRAM

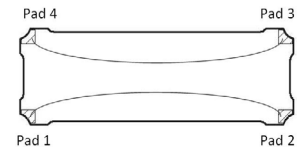

PRODUCT OVERVIEW

Mini-Circuits' BDCH-20-63A+ is a high-power bi-directional coupler providing high power handling up to 140W and mainline loss of 0.15 dB. Covering frequencies from 2000 to 6000 MHz, the model supports a wide variety of applications from power amplifiers and antenna feeds to various digital communications and more. High directivity of 29 dB provides accurate sampling from the coupled port, and 26 dB return loss provides excellent matching over full frequency range. The coupler is designed into an open printed laminate (1.00" x 0.35" x 0.067") with wrap-around terminations for good solderability and easy visual inspection.

ELECTRICAL SPECIFICATIONS^{1,2} AT +25°C

Parameter	Frequency (MHz)	Min.	Typ.	Max.	Units
Frequency Range		2000		6000	MHz
Insertion Loss ³	2000 - 6000	-	0.15	0.3	dB
Coupling Nominal	2000 - 6000	-	18±1	-	dB
Coupling Flatness (±)	2000 - 6000	-	±0.5	-	dB
Directivity	2000 - 6000	22	29	-	dB
Return Loss (Input/Output)	2000 - 6000	16	26	-	dB
Return Loss (Coupled Forward/Reverse)	2000 - 6000	16	26	-	dB
Thermal Resistance ⁴	2000 - 6000	-	0.3	-	°C/W

1. Tested on Evaluation Board TB-1036+. De-embedded to the device reference plane.

2. Model is symmetrical and all ports are interchangeable, see Port Function Description/Configuration table for details and S-Parameters for actual performance.

3. Does not include theoretical loss due to coupling. Nominal theoretical loss is 0.07 dB.

4. Thermal Resistance is defined as, example (θ_{jc})= (Hot Spot Temperature on DUT - Base Plate Temperature)/Input Power)

ABSOLUTE MAXIMUM RATINGS⁵

Operating Case Temperature ⁶	-55 °C to +105 °C	
Storage Temperature	-55 °C to +105 °C	
Power Input	+85 °C case	140 W
	+95 °C case	110 W
	+105 °C case	80 W
DC Current	2 A	

5. Permanent damage may occur if any of these limits are exceeded.

6. Case temperature is defined as temperature on base plate.





TYPICAL PERFORMANCE GRAPHS

Note : Data corresponds to Configuration A at +25°C unless specified otherwise.

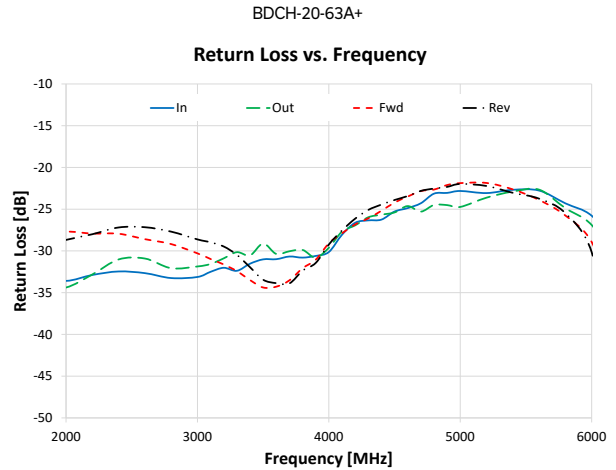
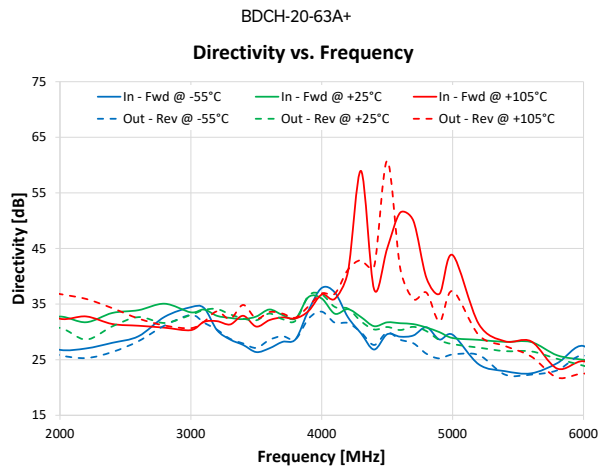
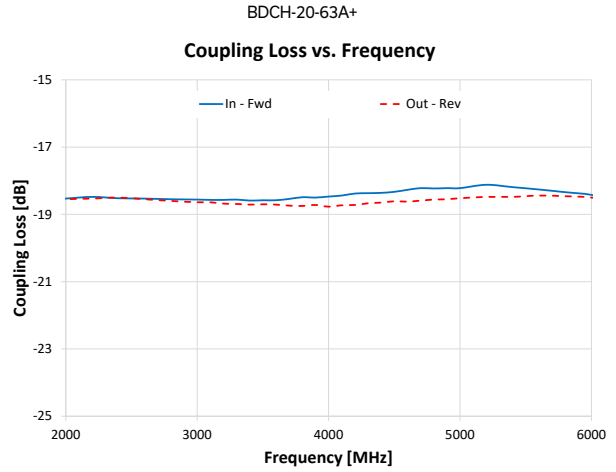
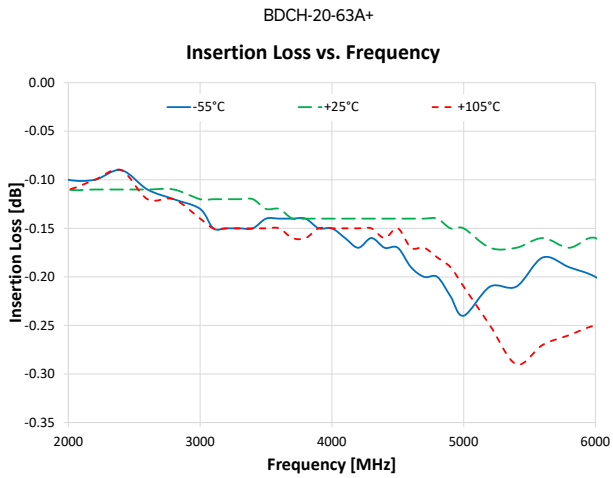



FUNCTIONAL DIAGRAM

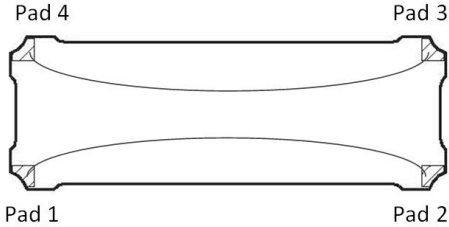

Figure 1. BDCH-20-63+ Functional Diagram

BLUE DESCRIPTION/CONFIGURATION⁷

Function	Pad Number	Description
Input	1	Connects to RF Input Port
Output	2	Connects to RF Output Port
Coupled Forward	4	Connects to Coupled Forward Port
Coupled Reverse	3	Connects to Coupled Reverse Port
Ground	5	Connects to Ground

Configuration	Input	Output	Coupled Forward	Coupled Reverse
A	1	2	4	3
B	2	1	3	4
C	3	4	2	1
D	4	3	1	2

7. Model is symmetrical and all ports are interchangeable, see Port Function Description/Configuration table for details and S-Parameters for actual performance.

SUGGESTED PCB LAYOUT (PL-578)

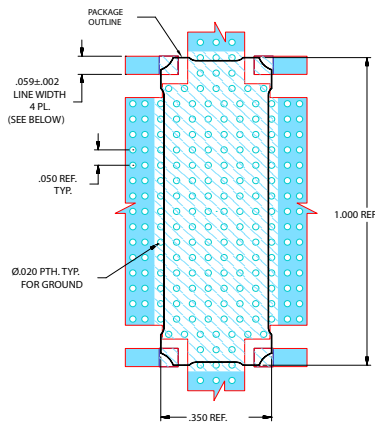

NOTES:
 1. TRACE WIDTH IS SHOWN FOR ROGERS RT/DUROID 5880 WITH DIELECTRIC THICKNESS, 0.020±.0015" COPPER; 1 OZ. EACH SIDE. FOR OTHER MATERIALS TRACE WIDTH MAY NEED TO BE MODIFIED.
 2. BOTTOM SIDE OF THE PCB IS CONTINUOUS GROUND PLANE.
 [Blue hatched box] DENOTES PCB COPPER LAYOUT WITH SMOBC (SOLDER MASK OVER BARE COPPER)
 [Red hatched box] DENOTES COPPER LAND PATTERN FREE OF SOLDERMASK

Figure 2. Suggested PCB Layout PL-578

CASE STYLE DRAWING (PQ2584)

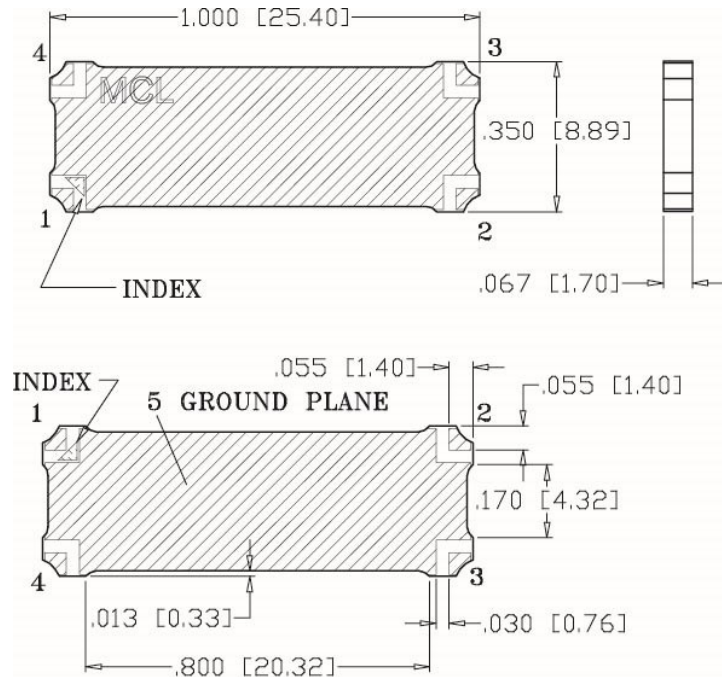

NOTES:
 1. DIMENSIONS INCH [MM].
 2. PIN NUMBERS DO NOT APPEAR ON UNIT, FOR REFERENCE ONLY.

[Blue hatched box] METALLIZATION [Red hatched box] SOLDER RESIST

PRODUCT MARKING*: BDCH-20-63A+

*Marking may contain other features or characters for internal lot control.



STRIPLINE SURFACE MOUNT

Bi-Directional Coupler

BDCH-20-63A+

50Ω 2000 to 6000 MHz 20 dB 140W

ADDITIONAL DETAILED INFORMATION IS AVAILABLE ON OUR DASH BOARD.

[CLICK HERE](#)

Performance Data & Graphs	Data Graphs S-Parameter (S4P Files) Data Set (.zip file) De-embedded to device pads
Case Style	PQ2584 Lead Finish: 2-5 inch (0.05-0.13 microns) Immersion Gold.
RoHS Status	Compliant
Tape and Reel	F118
Suggested Layout for PCB Design	PL-578
Evaluation Board	TB-1036+
	Gerber File
Environmental Rating	ENV02T8

NOTES

- A. Performance and quality attributes and conditions not expressly stated in this specification document are intended to be excluded and do not form a part of this specification document.
- B. Electrical specifications and performance data contained in this specification document are based on Mini-Circuits' applicable established test performance criteria and measurement instructions.
- C. The parts covered by this specification document are subject to Mini-Circuits' standard limited warranty and terms and conditions (collectively, "Standard Terms"); Purchasers of this part are entitled to the rights and benefits contained therein. For a full statement of the standard terms and the exclusive rights and remedies thereunder, please visit Mini-Circuits' website at www.minicircuits.com/terms/viewterm.html



Bi-Directional Coupler

BDCH-20-63A+

Typical Performance Data

Test Conditions: Input Power = +5 dbm, Temperature = -55°C, Configuration A.

Freq. (MHz)	I. Loss (dB) In - Out	Coupling (dB)		Directivity (dB) In - Fwd	Return Loss (dB)			
		In - Fwd	Out - Rev		In	Out	Fwd	Rev
1000	-0.06	-23.63	-23.63	31.94	-38.41	-36.34	-45.86	-50.07
1200	-0.07	-22.32	-22.32	33.30	-35.60	-36.02	-48.03	-45.94
1400	-0.07	-21.28	-21.30	33.08	-32.86	-34.64	-39.42	-40.98
1600	-0.08	-20.49	-20.52	31.82	-32.39	-37.79	-35.32	-37.11
1800	-0.10	-19.86	-19.90	31.32	-31.47	-38.27	-34.10	-36.77
2000	-0.09	-19.36	-19.36	31.62	-29.32	-32.71	-30.91	-34.88
2200	-0.08	-19.05	-19.08	29.03	-30.53	-31.55	-29.56	-33.61
2400	-0.08	-18.78	-18.79	31.96	-33.25	-33.43	-28.58	-30.67
2600	-0.10	-18.76	-18.69	28.26	-36.44	-47.51	-27.24	-28.45
2800	-0.10	-18.60	-18.58	26.90	-28.97	-29.18	-26.24	-27.14
3000	-0.09	-18.54	-18.51	27.65	-26.78	-25.47	-25.49	-25.24
3100	-0.09	-18.61	-18.57	28.59	-27.10	-25.55	-25.43	-24.61
3200	-0.09	-18.58	-18.60	27.98	-27.84	-26.91	-25.49	-24.25
3300	-0.11	-18.60	-18.59	30.01	-29.57	-29.31	-25.83	-24.34
3400	-0.12	-18.59	-18.50	30.55	-33.27	-32.19	-26.55	-25.29
3500	-0.13	-18.63	-18.65	35.35	-35.82	-32.72	-27.46	-26.44
3600	-0.13	-18.57	-18.68	34.76	-34.11	-31.27	-28.71	-27.74
3700	-0.16	-18.76	-18.71	40.21	-29.79	-28.05	-30.14	-29.38
3800	-0.15	-18.62	-18.73	29.41	-28.38	-26.19	-32.90	-31.10
3900	-0.14	-18.65	-18.77	27.62	-27.38	-25.39	-34.84	-32.10
4000	-0.14	-18.63	-18.74	26.32	-28.43	-25.76	-33.30	-31.93
4100	-0.14	-18.55	-18.74	27.19	-29.71	-27.71	-29.54	-28.60
4200	-0.14	-18.53	-18.80	29.30	-28.84	-29.49	-26.26	-25.07
4300	-0.15	-18.58	-18.79	34.55	-25.69	-27.48	-23.44	-22.89
4400	-0.15	-18.51	-18.81	35.46	-23.21	-23.93	-21.83	-21.70
4500	-0.16	-18.37	-18.71	34.12	-22.24	-21.98	-21.30	-21.53
4600	-0.17	-18.43	-18.72	32.74	-22.37	-21.12	-20.77	-21.03
4700	-0.17	-18.42	-18.68	28.02	-22.82	-21.42	-19.85	-20.05
4800	-0.18	-18.44	-18.68	29.71	-22.95	-22.24	-19.29	-19.10
4900	-0.19	-18.39	-18.65	28.72	-22.59	-22.98	-19.16	-18.61
5000	-0.20	-18.24	-18.72	31.10	-21.48	-23.99	-19.10	-18.46
5200	-0.24	-18.34	-18.65	28.33	-20.70	-23.27	-19.11	-19.28
5400	-0.21	-18.20	-18.61	24.94	-23.29	-22.69	-19.91	-20.37
5600	-0.17	-18.29	-18.56	23.41	-24.90	-24.21	-21.98	-21.75
5800	-0.17	-18.29	-18.39	25.41	-23.91	-25.18	-29.84	-29.16
6000	-0.21	-18.60	-18.47	26.49	-23.18	-24.40	-30.41	-32.07
6200	-0.22	-18.69	-18.79	21.84	-25.65	-25.53	-31.93	-33.36
6400	-0.23	-18.96	-18.86	21.78	-31.03	-34.46	-24.24	-24.19
6600	-0.29	-19.16	-19.12	19.72	-24.64	-24.07	-19.46	-18.84
6800	-0.32	-19.74	-19.72	17.30	-19.96	-20.50	-17.75	-17.78
7000	-0.39	-20.15	-19.76	13.37	-17.14	-17.17	-15.95	-15.87

Bi-Directional Coupler

BDCH-20-63A+

Typical Performance Data

Test Conditions: Input Power = +5 dbm, Temperature = -55°C, Configuration B.

Freq. (MHz)	I. Loss (dB) In - Out	Coupling (dB)		Directivity (dB) In - Fwd	Return Loss (dB)			
		In - Fwd	Out - Rev		In	Out	Fwd	Rev
1000	-0.07	-23.63	-23.63	29.47	-36.34	-38.41	-50.07	-45.86
1200	-0.07	-22.32	-22.32	29.81	-36.02	-35.60	-45.94	-48.03
1400	-0.08	-21.30	-21.28	29.01	-34.64	-32.86	-40.98	-39.42
1600	-0.09	-20.52	-20.49	28.31	-37.79	-32.39	-37.11	-35.32
1800	-0.11	-19.90	-19.86	27.78	-38.27	-31.47	-36.77	-34.10
2000	-0.09	-19.36	-19.36	27.10	-32.71	-29.32	-34.88	-30.91
2200	-0.09	-19.08	-19.05	26.87	-31.55	-30.53	-33.61	-29.56
2400	-0.09	-18.79	-18.78	27.45	-33.43	-33.25	-30.67	-28.58
2600	-0.10	-18.69	-18.76	31.33	-47.51	-36.44	-28.45	-27.24
2800	-0.11	-18.58	-18.60	25.74	-29.18	-28.97	-27.14	-26.24
3000	-0.10	-18.51	-18.54	25.08	-25.47	-26.78	-25.24	-25.49
3100	-0.09	-18.57	-18.61	27.69	-25.55	-27.10	-24.61	-25.43
3200	-0.10	-18.60	-18.58	27.62	-26.91	-27.84	-24.25	-25.49
3300	-0.11	-18.59	-18.60	29.09	-29.31	-29.57	-24.34	-25.83
3400	-0.13	-18.50	-18.59	28.76	-32.19	-33.27	-25.29	-26.55
3500	-0.13	-18.65	-18.63	32.28	-32.72	-35.82	-26.44	-27.46
3600	-0.14	-18.68	-18.57	32.79	-31.27	-34.11	-27.74	-28.71
3700	-0.16	-18.71	-18.76	31.67	-28.05	-29.79	-29.38	-30.14
3800	-0.15	-18.73	-18.62	31.19	-26.19	-28.38	-31.10	-32.90
3900	-0.15	-18.77	-18.65	28.11	-25.39	-27.38	-32.10	-34.84
4000	-0.15	-18.74	-18.63	27.04	-25.76	-28.43	-31.93	-33.30
4100	-0.15	-18.74	-18.55	28.22	-27.71	-29.71	-28.60	-29.54
4200	-0.15	-18.80	-18.53	30.33	-29.49	-28.84	-25.07	-26.26
4300	-0.16	-18.79	-18.58	34.10	-27.48	-25.69	-22.89	-23.44
4400	-0.16	-18.81	-18.51	33.96	-23.93	-23.21	-21.70	-21.83
4500	-0.17	-18.71	-18.37	29.32	-21.98	-22.24	-21.53	-21.30
4600	-0.17	-18.72	-18.43	31.31	-21.12	-22.37	-21.03	-20.77
4700	-0.18	-18.68	-18.42	28.42	-21.42	-22.82	-20.05	-19.85
4800	-0.18	-18.68	-18.44	29.88	-22.24	-22.95	-19.10	-19.29
4900	-0.20	-18.65	-18.39	29.50	-22.98	-22.59	-18.61	-19.16
5000	-0.22	-18.72	-18.24	28.20	-23.99	-21.48	-18.46	-19.10
5200	-0.27	-18.65	-18.34	25.75	-23.27	-20.70	-19.28	-19.11
5400	-0.25	-18.61	-18.20	24.70	-22.69	-23.29	-20.37	-19.91
5600	-0.21	-18.56	-18.29	22.56	-24.21	-24.90	-21.75	-21.98
5800	-0.19	-18.39	-18.29	23.83	-25.18	-23.91	-29.16	-29.84
6000	-0.22	-18.47	-18.60	24.75	-24.40	-23.18	-32.07	-30.41
6200	-0.24	-18.79	-18.69	22.13	-25.53	-25.65	-33.36	-31.93
6400	-0.25	-18.86	-18.96	21.10	-34.46	-31.03	-24.19	-24.24
6600	-0.30	-19.12	-19.16	16.74	-24.07	-24.64	-18.84	-19.46
6800	-0.34	-19.72	-19.74	18.15	-20.50	-19.96	-17.78	-17.75
7000	-0.41	-19.76	-20.15	16.64	-17.17	-17.14	-15.87	-15.95

Bi-Directional Coupler

BDCH-20-63A+

Typical Performance Data

Test Conditions: Input Power = +5 dbm, Temperature = -55°C, Configuration C.

Freq. (MHz)	I. Loss (dB) In - Out	Coupling (dB)		Directivity (dB) In - Fwd	Return Loss (dB)			
		In - Fwd	Out - Rev		In	Out	Fwd	Rev
1000	-0.06	-23.62	-23.63	32.10	-50.07	-45.86	-36.34	-38.41
1200	-0.07	-22.31	-22.32	33.06	-45.94	-48.03	-36.02	-35.60
1400	-0.08	-21.29	-21.28	32.76	-40.98	-39.42	-34.64	-32.86
1600	-0.08	-20.51	-20.49	31.71	-37.11	-35.32	-37.79	-32.39
1800	-0.09	-19.90	-19.86	31.20	-36.77	-34.10	-38.27	-31.47
2000	-0.09	-19.35	-19.36	31.70	-34.88	-30.91	-32.71	-29.32
2200	-0.10	-19.07	-19.06	29.07	-33.61	-29.56	-31.55	-30.53
2400	-0.10	-18.79	-18.78	32.00	-30.67	-28.58	-33.43	-33.25
2600	-0.12	-18.68	-18.76	28.25	-28.45	-27.24	-47.51	-36.44
2800	-0.12	-18.57	-18.60	26.91	-27.14	-26.24	-29.18	-28.97
3000	-0.12	-18.50	-18.55	27.58	-25.24	-25.49	-25.47	-26.78
3100	-0.12	-18.56	-18.61	28.52	-24.61	-25.43	-25.55	-27.10
3200	-0.12	-18.59	-18.58	27.57	-24.25	-25.49	-26.91	-27.84
3300	-0.13	-18.59	-18.60	29.16	-24.34	-25.83	-29.31	-29.57
3400	-0.13	-18.49	-18.59	29.83	-25.29	-26.55	-32.19	-33.27
3500	-0.12	-18.64	-18.63	34.23	-26.44	-27.46	-32.72	-35.82
3600	-0.12	-18.67	-18.58	33.22	-27.74	-28.71	-31.27	-34.11
3700	-0.13	-18.70	-18.77	37.48	-29.38	-30.14	-28.05	-29.79
3800	-0.11	-18.72	-18.62	28.94	-31.10	-32.90	-26.19	-28.38
3900	-0.12	-18.76	-18.65	27.50	-32.10	-34.84	-25.39	-27.38
4000	-0.11	-18.73	-18.63	26.71	-31.93	-33.30	-25.76	-28.43
4100	-0.12	-18.72	-18.55	27.44	-28.60	-29.54	-27.71	-29.71
4200	-0.14	-18.79	-18.53	29.21	-25.07	-26.26	-29.49	-28.84
4300	-0.14	-18.78	-18.58	33.25	-22.89	-23.44	-27.48	-25.69
4400	-0.15	-18.80	-18.51	33.81	-21.70	-21.83	-23.93	-23.21
4500	-0.15	-18.71	-18.36	32.12	-21.53	-21.30	-21.98	-22.24
4600	-0.16	-18.72	-18.42	30.85	-21.03	-20.77	-21.12	-22.37
4700	-0.16	-18.68	-18.42	26.90	-20.05	-19.85	-21.42	-22.82
4800	-0.18	-18.67	-18.44	28.93	-19.10	-19.29	-22.24	-22.95
4900	-0.20	-18.65	-18.39	28.66	-18.61	-19.16	-22.98	-22.59
5000	-0.21	-18.72	-18.24	31.85	-18.46	-19.10	-23.99	-21.48
5200	-0.21	-18.64	-18.35	28.27	-19.28	-19.11	-23.27	-20.70
5400	-0.22	-18.61	-18.20	23.97	-20.37	-19.91	-22.69	-23.29
5600	-0.20	-18.54	-18.30	22.62	-21.75	-21.98	-24.21	-24.90
5800	-0.17	-18.38	-18.32	25.83	-29.16	-29.84	-25.18	-23.91
6000	-0.18	-18.44	-18.62	27.99	-32.07	-30.41	-24.40	-23.18
6200	-0.19	-18.76	-18.71	22.26	-33.36	-31.93	-25.53	-25.65
6400	-0.21	-18.83	-18.98	21.89	-24.19	-24.24	-34.46	-31.03
6600	-0.29	-19.08	-19.17	19.12	-18.84	-19.46	-24.07	-24.64
6800	-0.28	-19.73	-19.75	16.96	-17.78	-17.75	-20.50	-19.96
7000	-0.36	-19.78	-20.15	13.81	-15.87	-15.95	-17.17	-17.14

Bi-Directional Coupler

BDCH-20-63A+

Typical Performance Data

Test Conditions: Input Power = +5 dbm, Temperature = -55°C, Configuration D.

Freq. (MHz)	I. Loss (dB) In - Out	Coupling (dB)		Directivity (dB) In - Fwd	Return Loss (dB)			
		In - Fwd	Out - Rev		In	Out	Fwd	Rev
1000	-0.07	-23.63	-23.62	40.08	-45.86	-50.07	-38.41	-36.34
1200	-0.07	-22.32	-22.31	36.42	-48.03	-45.94	-35.60	-36.02
1400	-0.07	-21.28	-21.29	34.64	-39.42	-40.98	-32.86	-34.64
1600	-0.08	-20.49	-20.51	31.80	-35.32	-37.11	-32.39	-37.79
1800	-0.08	-19.86	-19.90	30.00	-34.10	-36.77	-31.47	-38.27
2000	-0.09	-19.36	-19.35	30.99	-30.91	-34.88	-29.32	-32.71
2200	-0.09	-19.06	-19.07	27.41	-29.56	-33.61	-30.53	-31.55
2400	-0.10	-18.78	-18.79	27.64	-28.58	-30.67	-33.25	-33.43
2600	-0.11	-18.76	-18.68	26.46	-27.24	-28.45	-36.44	-47.51
2800	-0.11	-18.60	-18.57	26.17	-26.24	-27.14	-28.97	-29.18
3000	-0.12	-18.55	-18.50	26.26	-25.49	-25.24	-26.78	-25.47
3100	-0.12	-18.61	-18.56	26.17	-25.43	-24.61	-27.10	-25.55
3200	-0.12	-18.58	-18.59	25.87	-25.49	-24.25	-27.84	-26.91
3300	-0.12	-18.60	-18.59	26.68	-25.83	-24.34	-29.57	-29.31
3400	-0.12	-18.59	-18.49	27.57	-26.55	-25.29	-33.27	-32.19
3500	-0.12	-18.63	-18.64	26.75	-27.46	-26.44	-35.82	-32.72
3600	-0.12	-18.58	-18.67	27.32	-28.71	-27.74	-34.11	-31.27
3700	-0.13	-18.77	-18.70	29.34	-30.14	-29.38	-29.79	-28.05
3800	-0.11	-18.62	-18.72	29.47	-32.90	-31.10	-28.38	-26.19
3900	-0.11	-18.65	-18.76	32.31	-34.84	-32.10	-27.38	-25.39
4000	-0.11	-18.63	-18.73	32.36	-33.30	-31.93	-28.43	-25.76
4100	-0.12	-18.55	-18.72	34.81	-29.54	-28.60	-29.71	-27.71
4200	-0.14	-18.53	-18.79	40.26	-26.26	-25.07	-28.84	-29.49
4300	-0.14	-18.58	-18.78	51.79	-23.44	-22.89	-25.69	-27.48
4400	-0.15	-18.51	-18.80	41.28	-21.83	-21.70	-23.21	-23.93
4500	-0.15	-18.36	-18.71	50.40	-21.30	-21.53	-22.24	-21.98
4600	-0.16	-18.42	-18.72	38.51	-20.77	-21.03	-22.37	-21.12
4700	-0.16	-18.42	-18.68	37.93	-19.85	-20.05	-22.82	-21.42
4800	-0.17	-18.44	-18.67	31.44	-19.29	-19.10	-22.95	-22.24
4900	-0.20	-18.39	-18.65	30.17	-19.16	-18.61	-22.59	-22.98
5000	-0.19	-18.24	-18.72	33.04	-19.10	-18.46	-21.48	-23.99
5200	-0.20	-18.35	-18.64	25.85	-19.11	-19.28	-20.70	-23.27
5400	-0.21	-18.20	-18.61	26.44	-19.91	-20.37	-23.29	-22.69
5600	-0.19	-18.30	-18.54	23.65	-21.98	-21.75	-24.90	-24.21
5800	-0.16	-18.32	-18.38	21.57	-29.84	-29.16	-23.91	-25.18
6000	-0.18	-18.62	-18.44	19.53	-30.41	-32.07	-23.18	-24.40
6200	-0.18	-18.71	-18.76	18.07	-31.93	-33.36	-25.65	-25.53
6400	-0.20	-18.98	-18.83	17.65	-24.24	-24.19	-31.03	-34.46
6600	-0.28	-19.17	-19.08	18.12	-19.46	-18.84	-24.64	-24.07
6800	-0.27	-19.75	-19.73	15.98	-17.75	-17.78	-19.96	-20.50
7000	-0.36	-20.15	-19.78	13.29	-15.95	-15.87	-17.14	-17.17

Bi-Directional Coupler

BDCH-20-63A+

Typical Performance Data

Test Conditions: Input Power = +5 dbm, Temperature = +25°C, Configuration A.

Freq. (MHz)	I. Loss (dB) In - Out	Coupling (dB)		Directivity (dB) In - Fwd	Return Loss (dB)			
		In - Fwd	Out - Rev		In	Out	Fwd	Rev
1000	-0.05	-23.56	-23.55	43.20	-40.06	-37.99	-66.84	-47.05
1200	-0.06	-22.25	-22.24	41.41	-37.53	-37.99	-45.75	-43.76
1400	-0.07	-21.22	-21.23	37.60	-34.19	-36.95	-39.75	-40.49
1600	-0.07	-20.42	-20.43	36.55	-32.84	-36.98	-36.38	-37.92
1800	-0.08	-19.80	-19.82	35.55	-31.93	-37.26	-33.65	-35.98
2000	-0.07	-19.32	-19.34	34.06	-31.55	-35.99	-31.53	-34.52
2200	-0.07	-18.98	-19.00	32.29	-32.86	-37.98	-30.00	-33.38
2400	-0.09	-18.73	-18.75	32.10	-32.79	-36.29	-29.01	-31.70
2600	-0.10	-18.61	-18.63	31.72	-33.38	-35.16	-28.21	-29.84
2800	-0.11	-18.53	-18.55	32.77	-33.75	-34.47	-27.70	-28.61
3000	-0.11	-18.47	-18.52	31.37	-31.92	-31.88	-27.88	-27.69
3100	-0.11	-18.53	-18.48	34.26	-32.96	-31.40	-27.81	-27.40
3200	-0.10	-18.52	-18.52	33.43	-33.72	-31.26	-28.08	-27.17
3300	-0.11	-18.53	-18.55	34.04	-33.30	-31.71	-28.51	-27.20
3400	-0.11	-18.53	-18.57	34.44	-32.93	-32.03	-28.99	-27.67
3500	-0.12	-18.57	-18.60	35.29	-32.75	-31.84	-29.56	-28.04
3600	-0.12	-18.56	-18.65	33.53	-33.10	-31.94	-30.30	-28.66
3700	-0.13	-18.58	-18.64	34.23	-32.63	-31.42	-31.00	-29.42
3800	-0.12	-18.56	-18.69	32.75	-32.03	-30.99	-32.09	-30.15
3900	-0.12	-18.59	-18.71	32.49	-31.24	-30.20	-33.36	-31.76
4000	-0.13	-18.58	-18.70	32.63	-30.90	-29.11	-34.44	-33.57
4100	-0.13	-18.57	-18.72	33.51	-30.44	-29.39	-34.51	-34.16
4200	-0.14	-18.51	-18.73	33.46	-30.84	-30.55	-33.22	-33.61
4300	-0.14	-18.50	-18.72	36.66	-31.14	-31.06	-31.26	-31.59
4400	-0.14	-18.47	-18.77	36.24	-30.00	-29.60	-29.20	-29.29
4500	-0.14	-18.43	-18.72	33.93	-28.00	-27.57	-27.80	-27.41
4600	-0.14	-18.38	-18.69	32.29	-26.80	-26.07	-26.46	-25.71
4700	-0.14	-18.35	-18.65	31.91	-26.11	-25.74	-25.28	-24.53
4800	-0.14	-18.33	-18.61	31.60	-25.28	-25.46	-24.20	-23.86
4900	-0.14	-18.25	-18.61	30.75	-24.45	-24.58	-23.20	-23.23
5000	-0.14	-18.21	-18.59	31.68	-23.60	-24.73	-22.52	-22.56
5200	-0.15	-18.22	-18.51	28.93	-22.89	-24.67	-21.84	-21.99
5400	-0.16	-18.16	-18.51	28.94	-22.84	-23.37	-21.66	-22.04
5600	-0.15	-18.23	-18.46	27.95	-22.82	-22.85	-22.73	-23.10
5800	-0.15	-18.24	-18.48	25.77	-24.31	-23.70	-25.15	-25.36
6000	-0.17	-18.43	-18.50	24.89	-25.82	-26.93	-29.01	-30.37
6200	-0.19	-18.62	-18.66	24.39	-29.54	-31.56	-36.66	-45.12
6400	-0.21	-18.79	-18.89	24.37	-30.96	-30.78	-28.34	-28.97
6600	-0.23	-19.13	-19.16	20.28	-25.12	-27.98	-22.54	-22.68
6800	-0.23	-19.42	-19.44	19.87	-22.10	-22.37	-19.23	-18.98
7000	-0.27	-20.37	-20.19	16.86	-19.26	-18.90	-16.97	-16.66

Bi-Directional Coupler

BDCH-20-63A+

Typical Performance Data

Test Conditions: Input Power = +5 dbm, Temperature = +25°C, Configuration B.

Freq. (MHz)	I. Loss (dB) In - Out	Coupling (dB)		Directivity (dB) In - Fwd	Return Loss (dB)			
		In - Fwd	Out - Rev		In	Out	Fwd	Rev
1000	-0.06	-23.55	-23.56	36.05	-37.99	-40.06	-47.05	-66.84
1200	-0.06	-22.24	-22.25	34.79	-37.99	-37.53	-43.76	-45.75
1400	-0.07	-21.23	-21.22	32.82	-36.95	-34.19	-40.49	-39.75
1600	-0.08	-20.43	-20.42	32.55	-36.98	-32.84	-37.92	-36.38
1800	-0.08	-19.82	-19.80	31.34	-37.26	-31.93	-35.98	-33.65
2000	-0.08	-19.34	-19.32	29.97	-35.99	-31.55	-34.52	-31.53
2200	-0.08	-19.00	-18.98	28.84	-37.98	-32.86	-33.38	-30.00
2400	-0.09	-18.75	-18.73	29.08	-36.29	-32.79	-31.70	-29.01
2600	-0.11	-18.63	-18.61	30.02	-35.16	-33.38	-29.84	-28.21
2800	-0.12	-18.55	-18.53	30.67	-34.47	-33.75	-28.61	-27.70
3000	-0.11	-18.52	-18.47	28.09	-31.88	-31.92	-27.69	-27.88
3100	-0.11	-18.48	-18.53	30.94	-31.40	-32.96	-27.40	-27.81
3200	-0.11	-18.52	-18.52	32.58	-31.26	-33.72	-27.17	-28.08
3300	-0.11	-18.55	-18.53	32.52	-31.71	-33.30	-27.20	-28.51
3400	-0.12	-18.57	-18.53	31.16	-32.03	-32.93	-27.67	-28.99
3500	-0.12	-18.60	-18.57	32.25	-31.84	-32.75	-28.04	-29.56
3600	-0.12	-18.65	-18.56	32.98	-31.94	-33.10	-28.66	-30.30
3700	-0.13	-18.64	-18.58	34.24	-31.42	-32.63	-29.42	-31.00
3800	-0.13	-18.69	-18.56	33.54	-30.99	-32.03	-30.15	-32.09
3900	-0.13	-18.71	-18.59	32.94	-30.20	-31.24	-31.76	-33.36
4000	-0.14	-18.70	-18.58	31.86	-29.11	-30.90	-33.57	-34.44
4100	-0.14	-18.72	-18.57	32.82	-29.39	-30.44	-34.16	-34.51
4200	-0.15	-18.73	-18.51	33.23	-30.55	-30.84	-33.61	-33.22
4300	-0.15	-18.72	-18.50	36.20	-31.06	-31.14	-31.59	-31.26
4400	-0.15	-18.77	-18.47	37.14	-29.60	-30.00	-29.29	-29.20
4500	-0.15	-18.72	-18.43	34.69	-27.57	-28.00	-27.41	-27.80
4600	-0.15	-18.69	-18.38	32.59	-26.07	-26.80	-25.71	-26.46
4700	-0.15	-18.65	-18.35	31.30	-25.74	-26.11	-24.53	-25.28
4800	-0.15	-18.61	-18.33	30.75	-25.46	-25.28	-23.86	-24.20
4900	-0.15	-18.61	-18.25	30.23	-24.58	-24.45	-23.23	-23.20
5000	-0.16	-18.59	-18.21	31.23	-24.73	-23.60	-22.56	-22.52
5200	-0.17	-18.51	-18.22	27.74	-24.67	-22.89	-21.99	-21.84
5400	-0.19	-18.51	-18.16	27.52	-23.37	-22.84	-22.04	-21.66
5600	-0.18	-18.46	-18.23	26.21	-22.85	-22.82	-23.10	-22.73
5800	-0.18	-18.48	-18.24	24.92	-23.70	-24.31	-25.36	-25.15
6000	-0.19	-18.50	-18.43	23.85	-26.93	-25.82	-30.37	-29.01
6200	-0.22	-18.66	-18.62	22.58	-31.56	-29.54	-45.12	-36.66
6400	-0.24	-18.89	-18.79	23.14	-30.78	-30.96	-28.97	-28.34
6600	-0.26	-19.16	-19.13	19.23	-27.98	-25.12	-22.68	-22.54
6800	-0.27	-19.44	-19.42	18.79	-22.37	-22.10	-18.98	-19.23
7000	-0.30	-20.19	-20.37	17.79	-18.90	-19.26	-16.66	-16.97

Bi-Directional Coupler

BDCH-20-63A+

Typical Performance Data

Test Conditions: Input Power = +5 dbm, Temperature = +25°C, Configuration C.

Freq. (MHz)	I. Loss (dB) In - Out	Coupling (dB)		Directivity (dB) In - Fwd	Return Loss (dB)			
		In - Fwd	Out - Rev		In	Out	Fwd	Rev
1000	-0.04	-23.55	-23.56	43.88	-47.05	-66.84	-37.99	-40.06
1200	-0.05	-22.24	-22.25	41.01	-43.76	-45.75	-37.99	-37.53
1400	-0.05	-21.22	-21.22	37.33	-40.49	-39.75	-36.95	-34.19
1600	-0.06	-20.43	-20.43	36.43	-37.92	-36.38	-36.98	-32.84
1800	-0.07	-19.81	-19.81	35.39	-35.98	-33.65	-37.26	-31.93
2000	-0.07	-19.33	-19.33	34.20	-34.52	-31.53	-35.99	-31.55
2200	-0.07	-18.99	-18.99	32.40	-33.38	-30.00	-37.98	-32.86
2400	-0.08	-18.74	-18.74	32.16	-31.70	-29.01	-36.29	-32.79
2600	-0.09	-18.62	-18.62	31.43	-29.84	-28.21	-35.16	-33.38
2800	-0.09	-18.55	-18.54	32.73	-28.61	-27.70	-34.47	-33.75
3000	-0.09	-18.51	-18.48	31.15	-27.69	-27.88	-31.88	-31.92
3100	-0.10	-18.48	-18.53	33.87	-27.40	-27.81	-31.40	-32.96
3200	-0.10	-18.52	-18.53	32.64	-27.17	-28.08	-31.26	-33.72
3300	-0.10	-18.55	-18.53	32.82	-27.20	-28.51	-31.71	-33.30
3400	-0.10	-18.57	-18.54	32.98	-27.67	-28.99	-32.03	-32.93
3500	-0.11	-18.60	-18.58	33.91	-28.04	-29.56	-31.84	-32.75
3600	-0.11	-18.64	-18.57	32.50	-28.66	-30.30	-31.94	-33.10
3700	-0.12	-18.64	-18.59	33.88	-29.42	-31.00	-31.42	-32.63
3800	-0.12	-18.69	-18.57	33.13	-30.15	-32.09	-30.99	-32.03
3900	-0.12	-18.70	-18.60	33.22	-31.76	-33.36	-30.20	-31.24
4000	-0.12	-18.69	-18.59	33.83	-33.57	-34.44	-29.11	-30.90
4100	-0.13	-18.71	-18.58	34.32	-34.16	-34.51	-29.39	-30.44
4200	-0.14	-18.72	-18.52	33.22	-33.61	-33.22	-30.55	-30.84
4300	-0.14	-18.71	-18.50	35.30	-31.59	-31.26	-31.06	-31.14
4400	-0.15	-18.76	-18.46	34.21	-29.29	-29.20	-29.60	-30.00
4500	-0.15	-18.72	-18.42	31.94	-27.41	-27.80	-27.57	-28.00
4600	-0.15	-18.69	-18.38	30.55	-25.71	-26.46	-26.07	-26.80
4700	-0.16	-18.65	-18.35	30.68	-24.53	-25.28	-25.74	-26.11
4800	-0.17	-18.60	-18.33	31.47	-23.86	-24.20	-25.46	-25.28
4900	-0.17	-18.61	-18.26	31.39	-23.23	-23.20	-24.58	-24.45
5000	-0.18	-18.59	-18.22	32.93	-22.56	-22.52	-24.73	-23.60
5200	-0.18	-18.52	-18.23	29.06	-21.99	-21.84	-24.67	-22.89
5400	-0.20	-18.50	-18.17	27.86	-22.04	-21.66	-23.37	-22.84
5600	-0.19	-18.45	-18.25	27.37	-23.10	-22.73	-22.85	-22.82
5800	-0.19	-18.45	-18.25	26.39	-25.36	-25.15	-23.70	-24.31
6000	-0.17	-18.47	-18.46	25.79	-30.37	-29.01	-26.93	-25.82
6200	-0.18	-18.63	-18.66	24.55	-45.12	-36.66	-31.56	-29.54
6400	-0.20	-18.86	-18.81	23.63	-28.97	-28.34	-30.78	-30.96
6600	-0.24	-19.15	-19.15	19.70	-22.68	-22.54	-27.98	-25.12
6800	-0.28	-19.47	-19.45	19.87	-18.98	-19.23	-22.37	-22.10
7000	-0.35	-20.19	-20.40	17.24	-16.66	-16.97	-18.90	-19.26

Bi-Directional Coupler

BDCH-20-63A+

Typical Performance Data

Test Conditions: Input Power = +5 dbm, Temperature = +25°C, Configuration D.

Freq. (MHz)	I. Loss (dB) In - Out	Coupling (dB)		Directivity (dB) In - Fwd	Return Loss (dB)			
		In - Fwd	Out - Rev		In	Out	Fwd	Rev
1000	-0.04	-23.56	-23.55	42.79	-66.84	-47.05	-40.06	-37.99
1200	-0.05	-22.25	-22.24	38.87	-45.75	-43.76	-37.53	-37.99
1400	-0.06	-21.22	-21.22	36.10	-39.75	-40.49	-34.19	-36.95
1600	-0.06	-20.43	-20.43	34.68	-36.38	-37.92	-32.84	-36.98
1800	-0.07	-19.81	-19.81	33.12	-33.65	-35.98	-31.93	-37.26
2000	-0.07	-19.33	-19.33	31.91	-31.53	-34.52	-31.55	-35.99
2200	-0.08	-18.99	-18.99	29.78	-30.00	-33.38	-32.86	-37.98
2400	-0.08	-18.74	-18.74	29.43	-29.01	-31.70	-32.79	-36.29
2600	-0.09	-18.62	-18.62	28.28	-28.21	-29.84	-33.38	-35.16
2800	-0.10	-18.54	-18.55	28.76	-27.70	-28.61	-33.75	-34.47
3000	-0.09	-18.48	-18.51	29.08	-27.88	-27.69	-31.92	-31.88
3100	-0.10	-18.53	-18.48	30.60	-27.81	-27.40	-32.96	-31.40
3200	-0.10	-18.53	-18.52	30.09	-28.08	-27.17	-33.72	-31.26
3300	-0.10	-18.53	-18.55	29.91	-28.51	-27.20	-33.30	-31.71
3400	-0.10	-18.54	-18.57	30.30	-28.99	-27.67	-32.93	-32.03
3500	-0.11	-18.58	-18.60	31.08	-29.56	-28.04	-32.75	-31.84
3600	-0.11	-18.57	-18.64	30.64	-30.30	-28.66	-33.10	-31.94
3700	-0.12	-18.59	-18.64	31.58	-31.00	-29.42	-32.63	-31.42
3800	-0.12	-18.57	-18.69	31.79	-32.09	-30.15	-32.03	-30.99
3900	-0.12	-18.60	-18.70	32.68	-33.36	-31.76	-31.24	-30.20
4000	-0.13	-18.59	-18.69	33.72	-34.44	-33.57	-30.90	-29.11
4100	-0.13	-18.58	-18.71	35.04	-34.51	-34.16	-30.44	-29.39
4200	-0.14	-18.52	-18.72	34.33	-33.22	-33.61	-30.84	-30.55
4300	-0.14	-18.50	-18.71	37.10	-31.26	-31.59	-31.14	-31.06
4400	-0.15	-18.46	-18.76	35.59	-29.20	-29.29	-30.00	-29.60
4500	-0.15	-18.42	-18.72	35.72	-27.80	-27.41	-28.00	-27.57
4600	-0.15	-18.38	-18.69	36.29	-26.46	-25.71	-26.80	-26.07
4700	-0.15	-18.35	-18.65	35.68	-25.28	-24.53	-26.11	-25.74
4800	-0.16	-18.33	-18.60	34.40	-24.20	-23.86	-25.28	-25.46
4900	-0.16	-18.26	-18.61	32.44	-23.20	-23.23	-24.45	-24.58
5000	-0.16	-18.22	-18.59	31.79	-22.52	-22.56	-23.60	-24.73
5200	-0.17	-18.23	-18.52	28.54	-21.84	-21.99	-22.89	-24.67
5400	-0.19	-18.17	-18.50	28.38	-21.66	-22.04	-22.84	-23.37
5600	-0.18	-18.25	-18.45	27.31	-22.73	-23.10	-22.82	-22.85
5800	-0.18	-18.25	-18.45	25.95	-25.15	-25.36	-24.31	-23.70
6000	-0.17	-18.46	-18.47	23.70	-29.01	-30.37	-25.82	-26.93
6200	-0.18	-18.66	-18.63	22.88	-36.66	-45.12	-29.54	-31.56
6400	-0.20	-18.81	-18.86	22.14	-28.34	-28.97	-30.96	-30.78
6600	-0.24	-19.15	-19.15	20.65	-22.54	-22.68	-25.12	-27.98
6800	-0.28	-19.45	-19.47	19.76	-19.23	-18.98	-22.10	-22.37
7000	-0.36	-20.40	-20.19	16.36	-16.97	-16.66	-19.26	-18.90

Bi-Directional Coupler

BDCH-20-63A+

Typical Performance Data

Test Conditions: Input Power = +5 dbm, Temperature = +105°C, Configuration A.

Freq. (MHz)	I. Loss (dB) In - Out	Coupling (dB)		Directivity (dB) In - Fwd	Return Loss (dB)			
		In - Fwd	Out - Rev		In	Out	Fwd	Rev
1000	-0.05	-23.49	-23.50	38.34	-41.62	-38.22	-57.65	-48.59
1200	-0.05	-22.18	-22.19	37.41	-36.50	-35.89	-48.15	-45.59
1400	-0.06	-21.15	-21.18	38.88	-34.53	-34.75	-41.85	-43.23
1600	-0.07	-20.37	-20.39	40.48	-34.11	-35.39	-37.38	-39.71
1800	-0.07	-19.74	-19.76	41.66	-33.96	-36.44	-33.51	-35.46
2000	-0.08	-19.25	-19.27	39.77	-33.40	-35.57	-30.70	-32.21
2200	-0.08	-18.95	-18.99	44.59	-32.09	-35.01	-28.94	-30.45
2400	-0.11	-18.67	-18.74	39.39	-29.82	-33.29	-27.89	-29.13
2600	-0.13	-18.64	-18.50	30.75	-28.86	-30.33	-27.12	-28.45
2800	-0.11	-18.48	-18.52	32.71	-27.78	-28.24	-27.27	-27.61
3000	-0.09	-18.42	-18.46	34.22	-28.84	-28.92	-27.30	-27.63
3100	-0.09	-18.50	-18.49	30.58	-29.77	-30.86	-27.38	-27.90
3200	-0.09	-18.48	-18.54	29.65	-30.36	-31.81	-28.05	-28.03
3300	-0.11	-18.50	-18.54	30.62	-31.19	-34.07	-29.08	-28.29
3400	-0.12	-18.44	-18.51	32.04	-32.47	-36.66	-29.78	-28.99
3500	-0.13	-18.51	-18.63	31.38	-32.09	-34.61	-29.71	-29.64
3600	-0.14	-18.44	-18.63	30.55	-31.06	-33.06	-29.71	-30.43
3700	-0.17	-18.55	-18.54	35.59	-30.20	-31.64	-29.84	-31.74
3800	-0.15	-18.55	-18.67	32.68	-29.43	-30.72	-30.72	-32.34
3900	-0.15	-18.54	-18.74	32.49	-29.32	-29.37	-32.21	-32.37
4000	-0.15	-18.54	-18.74	31.05	-28.66	-28.46	-34.64	-33.13
4100	-0.15	-18.46	-18.70	31.23	-28.63	-28.88	-37.13	-34.39
4200	-0.15	-18.46	-18.73	33.64	-29.34	-29.51	-39.31	-35.96
4300	-0.16	-18.46	-18.78	32.92	-31.17	-30.55	-41.47	-38.08
4400	-0.15	-18.39	-18.76	35.12	-35.57	-36.89	-40.23	-39.63
4500	-0.15	-18.27	-18.71	41.64	-43.11	-43.75	-38.86	-38.59
4600	-0.15	-18.36	-18.67	37.84	-38.39	-32.65	-35.62	-34.39
4700	-0.16	-18.31	-18.65	43.29	-33.09	-28.82	-32.89	-33.19
4800	-0.15	-18.31	-18.60	45.06	-30.00	-26.29	-30.12	-30.88
4900	-0.17	-18.27	-18.57	38.30	-28.33	-24.55	-28.96	-29.28
5000	-0.17	-18.13	-18.65	39.14	-26.61	-25.51	-28.11	-28.08
5200	-0.21	-18.22	-18.60	39.73	-23.12	-24.67	-27.29	-27.12
5400	-0.25	-18.14	-18.55	32.65	-22.58	-21.57	-24.38	-25.20
5600	-0.27	-18.21	-18.55	29.20	-22.40	-20.90	-22.52	-23.43
5800	-0.27	-18.36	-18.54	26.85	-23.66	-23.27	-22.93	-23.90
6000	-0.25	-18.55	-18.51	24.27	-29.08	-34.00	-26.48	-27.06
6200	-0.25	-18.63	-18.76	22.14	-29.56	-28.98	-32.78	-31.64
6400	-0.27	-19.00	-18.90	21.89	-29.67	-27.07	-35.63	-34.56
6600	-0.31	-19.17	-19.23	18.94	-24.98	-23.74	-25.54	-25.18
6800	-0.30	-19.60	-19.55	18.42	-21.59	-21.34	-20.30	-20.82
7000	-0.35	-20.41	-20.17	16.36	-19.98	-19.57	-17.90	-18.18

NOTES:

- A. Performance and quality attributes and conditions not expressly stated in this specification document are intended to be excluded and do not form a part of this specification document.
- B. Electrical specifications and performance data contained in this specification document are based on Mini-Circuit's applicable established test performance criteria and measurement instructions.
- C. The parts covered by this specification document are subject to Mini-Circuits standard limited warranty and terms and conditions (collectively, "Standard Terms"); Purchasers of this part are entitled to the rights and benefits contained therein. For a full statement of the Standard Terms and the exclusive rights and remedies thereunder, please visit Mini-Circuits' website at <https://www.minicircuits.com/terms/viewterm.html>



Bi-Directional Coupler

BDCH-20-63A+

Typical Performance Data

Test Conditions: Input Power = +5 dbm, Temperature = +105°C, Configuration B.

Freq. (MHz)	I. Loss (dB) In - Out	Coupling (dB)		Directivity (dB) In - Fwd	Return Loss (dB)			
		In - Fwd	Out - Rev		In	Out	Fwd	Rev
1000	-0.05	-23.50	-23.49	32.70	-38.22	-41.62	-48.59	-57.65
1200	-0.06	-22.19	-22.18	31.64	-35.89	-36.50	-45.59	-48.15
1400	-0.07	-21.18	-21.15	32.22	-34.75	-34.53	-43.23	-41.85
1600	-0.07	-20.39	-20.37	33.33	-35.39	-34.11	-39.71	-37.38
1800	-0.08	-19.76	-19.74	34.67	-36.44	-33.96	-35.46	-33.51
2000	-0.08	-19.27	-19.25	36.10	-35.57	-33.40	-32.21	-30.70
2200	-0.09	-18.99	-18.95	37.18	-35.01	-32.09	-30.45	-28.94
2400	-0.12	-18.74	-18.67	36.91	-33.29	-29.82	-29.13	-27.89
2600	-0.14	-18.50	-18.64	36.19	-30.33	-28.86	-28.45	-27.12
2800	-0.12	-18.52	-18.48	37.01	-28.24	-27.78	-27.61	-27.27
3000	-0.10	-18.46	-18.42	36.73	-28.92	-28.84	-27.63	-27.30
3100	-0.10	-18.49	-18.50	34.89	-30.86	-29.77	-27.90	-27.38
3200	-0.10	-18.54	-18.48	31.60	-31.81	-30.36	-28.03	-28.05
3300	-0.12	-18.54	-18.50	31.80	-34.07	-31.19	-28.29	-29.08
3400	-0.13	-18.51	-18.44	30.56	-36.66	-32.47	-28.99	-29.78
3500	-0.14	-18.63	-18.51	31.56	-34.61	-32.09	-29.64	-29.71
3600	-0.15	-18.63	-18.44	30.60	-33.06	-31.06	-30.43	-29.71
3700	-0.18	-18.54	-18.55	32.27	-31.64	-30.20	-31.74	-29.84
3800	-0.16	-18.67	-18.55	34.26	-30.72	-29.43	-32.34	-30.72
3900	-0.16	-18.74	-18.54	34.34	-29.37	-29.32	-32.37	-32.21
4000	-0.16	-18.74	-18.54	32.87	-28.46	-28.66	-33.13	-34.64
4100	-0.16	-18.70	-18.46	32.61	-28.88	-28.63	-34.39	-37.13
4200	-0.16	-18.73	-18.46	34.11	-29.51	-29.34	-35.96	-39.31
4300	-0.17	-18.78	-18.46	33.14	-30.55	-31.17	-38.08	-41.47
4400	-0.16	-18.76	-18.39	36.07	-36.89	-35.57	-39.63	-40.23
4500	-0.16	-18.71	-18.27	46.91	-43.75	-43.11	-38.59	-38.86
4600	-0.16	-18.67	-18.36	38.18	-32.65	-38.39	-34.39	-35.62
4700	-0.16	-18.65	-18.31	55.02	-28.82	-33.09	-33.19	-32.89
4800	-0.16	-18.60	-18.31	53.71	-26.29	-30.00	-30.88	-30.12
4900	-0.18	-18.57	-18.27	34.08	-24.55	-28.33	-29.28	-28.96
5000	-0.20	-18.65	-18.13	45.09	-25.51	-26.61	-28.08	-28.11
5200	-0.24	-18.60	-18.22	35.93	-24.67	-23.12	-27.12	-27.29
5400	-0.29	-18.55	-18.14	30.23	-21.57	-22.58	-25.20	-24.38
5600	-0.30	-18.55	-18.21	26.84	-20.90	-22.40	-23.43	-22.52
5800	-0.29	-18.54	-18.36	25.00	-23.27	-23.66	-23.90	-22.93
6000	-0.28	-18.51	-18.55	22.42	-34.00	-29.08	-27.06	-26.48
6200	-0.28	-18.76	-18.63	21.59	-28.98	-29.56	-31.64	-32.78
6400	-0.30	-18.90	-19.00	20.92	-27.07	-29.67	-34.56	-35.63
6600	-0.34	-19.23	-19.17	17.67	-23.74	-24.98	-25.18	-25.54
6800	-0.33	-19.55	-19.60	17.32	-21.34	-21.59	-20.82	-20.30
7000	-0.38	-20.17	-20.41	15.63	-19.57	-19.98	-18.18	-17.90

NOTES:

- A. Performance and quality attributes and conditions not expressly stated in this specification document are intended to be excluded and do not form a part of this specification document.
- B. Electrical specifications and performance data contained in this specification document are based on Mini-Circuit's applicable established test performance criteria and measurement instructions.
- C. The parts covered by this specification document are subject to Mini-Circuits standard limited warranty and terms and conditions (collectively, "Standard Terms"); Purchasers of this part are entitled to the rights and benefits contained therein. For a full statement of the Standard Terms and the exclusive rights and remedies thereunder, please visit Mini-Circuits' website at <https://www.minicircuits.com/terms/viewterm.html>



Bi-Directional Coupler

Typical Performance Data

Test Conditions: Input Power = +5 dbm, Temperature = +105°C, Configuration C.

Freq. (MHz)	I. Loss (dB) In - Out	Coupling (dB)		Directivity (dB) In - Fwd	Return Loss (dB)			
		In - Fwd	Out - Rev		In	Out	Fwd	Rev
1000	-0.02	-23.49	-23.49	38.34	-48.59	-57.65	-38.22	-41.62
1200	-0.03	-22.18	-22.19	36.90	-45.59	-48.15	-35.89	-36.50
1400	-0.03	-21.16	-21.16	38.13	-43.23	-41.85	-34.75	-34.53
1600	-0.04	-20.38	-20.37	40.36	-39.71	-37.38	-35.39	-34.11
1800	-0.05	-19.75	-19.75	42.06	-35.46	-33.51	-36.44	-33.96
2000	-0.06	-19.25	-19.25	39.38	-32.21	-30.70	-35.57	-33.40
2200	-0.06	-18.98	-18.96	45.16	-30.45	-28.94	-35.01	-32.09
2400	-0.07	-18.73	-18.68	39.87	-29.13	-27.89	-33.29	-29.82
2600	-0.09	-18.49	-18.64	31.13	-28.45	-27.12	-30.33	-28.86
2800	-0.08	-18.51	-18.48	32.69	-27.61	-27.27	-28.24	-27.78
3000	-0.08	-18.45	-18.42	34.39	-27.63	-27.30	-28.92	-28.84
3100	-0.09	-18.48	-18.50	30.84	-27.90	-27.38	-30.86	-29.77
3200	-0.09	-18.53	-18.48	29.33	-28.03	-28.05	-31.81	-30.36
3300	-0.10	-18.53	-18.50	29.90	-28.29	-29.08	-34.07	-31.19
3400	-0.09	-18.50	-18.44	30.92	-28.99	-29.78	-36.66	-32.47
3500	-0.10	-18.62	-18.51	30.43	-29.64	-29.71	-34.61	-32.09
3600	-0.10	-18.62	-18.45	30.07	-30.43	-29.71	-33.06	-31.06
3700	-0.11	-18.53	-18.56	37.96	-31.74	-29.84	-31.64	-30.20
3800	-0.10	-18.66	-18.56	33.67	-32.34	-30.72	-30.72	-29.43
3900	-0.10	-18.73	-18.55	33.54	-32.37	-32.21	-29.37	-29.32
4000	-0.10	-18.73	-18.55	31.93	-33.13	-34.64	-28.46	-28.66
4100	-0.10	-18.69	-18.46	31.26	-34.39	-37.13	-28.88	-28.63
4200	-0.11	-18.71	-18.46	32.59	-35.96	-39.31	-29.51	-29.34
4300	-0.12	-18.76	-18.46	31.96	-38.08	-41.47	-30.55	-31.17
4400	-0.11	-18.75	-18.39	34.25	-39.63	-40.23	-36.89	-35.57
4500	-0.12	-18.70	-18.27	41.41	-38.59	-38.86	-43.75	-43.11
4600	-0.12	-18.66	-18.36	41.61	-34.39	-35.62	-32.65	-38.39
4700	-0.13	-18.64	-18.30	46.55	-33.19	-32.89	-28.82	-33.09
4800	-0.13	-18.59	-18.31	60.41	-30.88	-30.12	-26.29	-30.00
4900	-0.15	-18.56	-18.27	38.85	-29.28	-28.96	-24.55	-28.33
5000	-0.17	-18.64	-18.13	42.38	-28.08	-28.11	-25.51	-26.61
5200	-0.18	-18.60	-18.22	40.00	-27.12	-27.29	-24.67	-23.12
5400	-0.21	-18.54	-18.14	31.17	-25.20	-24.38	-21.57	-22.58
5600	-0.21	-18.53	-18.22	28.41	-23.43	-22.52	-20.90	-22.40
5800	-0.22	-18.50	-18.37	27.48	-23.90	-22.93	-23.27	-23.66
6000	-0.23	-18.47	-18.58	25.11	-27.06	-26.48	-34.00	-29.08
6200	-0.23	-18.73	-18.66	22.03	-31.64	-32.78	-28.98	-29.56
6400	-0.23	-18.87	-19.03	21.44	-34.56	-35.63	-27.07	-29.67
6600	-0.30	-19.21	-19.20	18.82	-25.18	-25.54	-23.74	-24.98
6800	-0.31	-19.57	-19.63	18.86	-20.82	-20.30	-21.34	-21.59
7000	-0.36	-20.19	-20.43	16.97	-18.18	-17.90	-19.57	-19.98

NOTES:

- A. Performance and quality attributes and conditions not expressly stated in this specification document are intended to be excluded and do not form a part of this specification document.
- B. Electrical specifications and performance data contained in this specification document are based on Mini-Circuit's applicable established test performance criteria and measurement instructions.
- C. The parts covered by this specification document are subject to Mini-Circuits standard limited warranty and terms and conditions (collectively, "Standard Terms"); Purchasers of this part are entitled to the rights and benefits contained therein. For a full statement of the Standard Terms and the exclusive rights and remedies thereunder, please visit Mini-Circuits' website at <https://www.minicircuits.com/terms/viewterm.html>



Bi-Directional Coupler

BDCH-20-63A+

Typical Performance Data

Test Conditions: Input Power = +5 dbm, Temperature = +105°C, Configuration D.

Freq. (MHz)	I. Loss (dB) In - Out	Coupling (dB)		Directivity (dB) In - Fwd	Return Loss (dB)			
		In - Fwd	Out - Rev		In	Out	Fwd	Rev
1000	-0.02	-23.49	-23.49	44.24	-57.65	-48.59	-41.62	-38.22
1200	-0.03	-22.19	-22.18	44.98	-48.15	-45.59	-36.50	-35.89
1400	-0.03	-21.16	-21.16	48.02	-41.85	-43.23	-34.53	-34.75
1600	-0.04	-20.37	-20.38	46.41	-37.38	-39.71	-34.11	-35.39
1800	-0.05	-19.75	-19.75	43.96	-33.51	-35.46	-33.96	-36.44
2000	-0.05	-19.25	-19.25	39.34	-30.70	-32.21	-33.40	-35.57
2200	-0.06	-18.96	-18.98	35.19	-28.94	-30.45	-32.09	-35.01
2400	-0.06	-18.68	-18.73	34.74	-27.89	-29.13	-29.82	-33.29
2600	-0.09	-18.64	-18.49	29.97	-27.12	-28.45	-28.86	-30.33
2800	-0.08	-18.48	-18.51	32.65	-27.27	-27.61	-27.78	-28.24
3000	-0.08	-18.42	-18.45	36.26	-27.30	-27.63	-28.84	-28.92
3100	-0.09	-18.50	-18.48	31.80	-27.38	-27.90	-29.77	-30.86
3200	-0.09	-18.48	-18.53	31.64	-28.05	-28.03	-30.36	-31.81
3300	-0.09	-18.50	-18.53	32.42	-29.08	-28.29	-31.19	-34.07
3400	-0.09	-18.44	-18.50	36.83	-29.78	-28.99	-32.47	-36.66
3500	-0.09	-18.51	-18.62	32.21	-29.71	-29.64	-32.09	-34.61
3600	-0.09	-18.45	-18.62	32.42	-29.71	-30.43	-31.06	-33.06
3700	-0.11	-18.56	-18.53	49.63	-29.84	-31.74	-30.20	-31.64
3800	-0.10	-18.56	-18.66	34.94	-30.72	-32.34	-29.43	-30.72
3900	-0.10	-18.55	-18.73	34.48	-32.21	-32.37	-29.32	-29.37
4000	-0.10	-18.55	-18.73	36.03	-34.64	-33.13	-28.66	-28.46
4100	-0.10	-18.46	-18.69	36.34	-37.13	-34.39	-28.63	-28.88
4200	-0.11	-18.46	-18.71	35.06	-39.31	-35.96	-29.34	-29.51
4300	-0.12	-18.46	-18.76	38.13	-41.47	-38.08	-31.17	-30.55
4400	-0.11	-18.39	-18.75	34.65	-40.23	-39.63	-35.57	-36.89
4500	-0.12	-18.27	-18.70	35.67	-38.86	-38.59	-43.11	-43.75
4600	-0.12	-18.36	-18.66	38.21	-35.62	-34.39	-38.39	-32.65
4700	-0.12	-18.30	-18.64	32.58	-32.89	-33.19	-33.09	-28.82
4800	-0.12	-18.31	-18.59	31.70	-30.12	-30.88	-30.00	-26.29
4900	-0.14	-18.27	-18.56	31.83	-28.96	-29.28	-28.33	-24.55
5000	-0.15	-18.13	-18.64	35.61	-28.11	-28.08	-26.61	-25.51
5200	-0.17	-18.22	-18.60	32.59	-27.29	-27.12	-23.12	-24.67
5400	-0.20	-18.14	-18.54	30.51	-24.38	-25.20	-22.58	-21.57
5600	-0.20	-18.22	-18.53	29.48	-22.52	-23.43	-22.40	-20.90
5800	-0.22	-18.37	-18.50	30.06	-22.93	-23.90	-23.66	-23.27
6000	-0.23	-18.58	-18.47	25.51	-26.48	-27.06	-29.08	-34.00
6200	-0.22	-18.66	-18.73	22.36	-32.78	-31.64	-29.56	-28.98
6400	-0.23	-19.03	-18.87	23.83	-35.63	-34.56	-29.67	-27.07
6600	-0.29	-19.20	-19.21	21.68	-25.54	-25.18	-24.98	-23.74
6800	-0.30	-19.63	-19.57	19.75	-20.30	-20.82	-21.59	-21.34
7000	-0.36	-20.43	-20.19	16.50	-17.90	-18.18	-19.98	-19.57

NOTES:

- A. Performance and quality attributes and conditions not expressly stated in this specification document are intended to be excluded and do not form a part of this specification document.
- B. Electrical specifications and performance data contained in this specification document are based on Mini-Circuit's applicable established test performance criteria and measurement instructions.
- C. The parts covered by this specification document are subject to Mini-Circuits standard limited warranty and terms and conditions (collectively, "Standard Terms"); Purchasers of this part are entitled to the rights and benefits contained therein. For a full statement of the Standard Terms and the exclusive rights and remedies thereunder, please visit Mini-Circuits' website at <https://www.minicircuits.com/terms/viewterm.html>



Bi-Directional Coupler

BDCH-20-63A+

Typical Performance Graphs

Test Conditions: Input Power = +5 dbm, Configuration A.

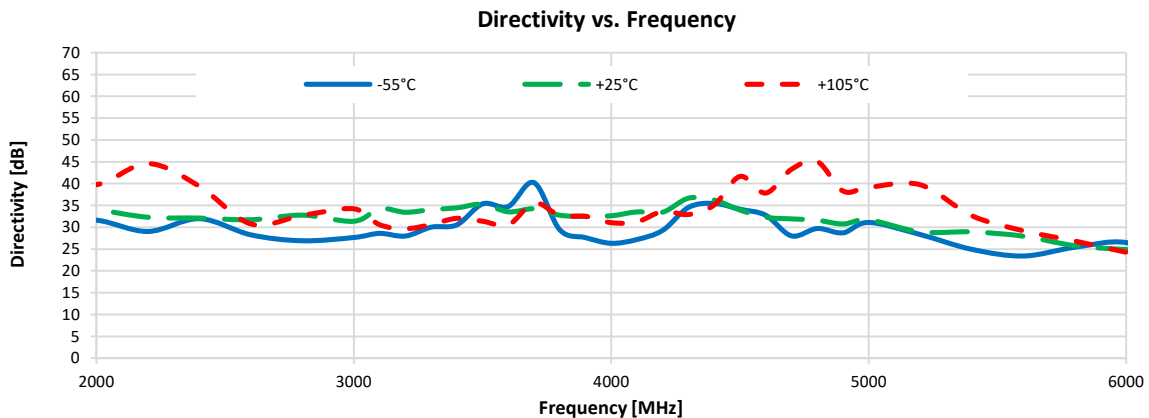
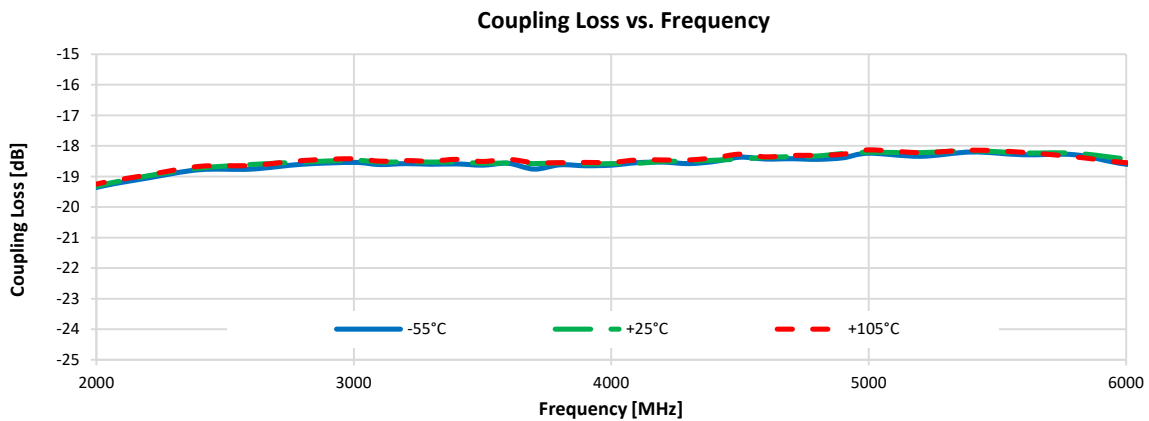
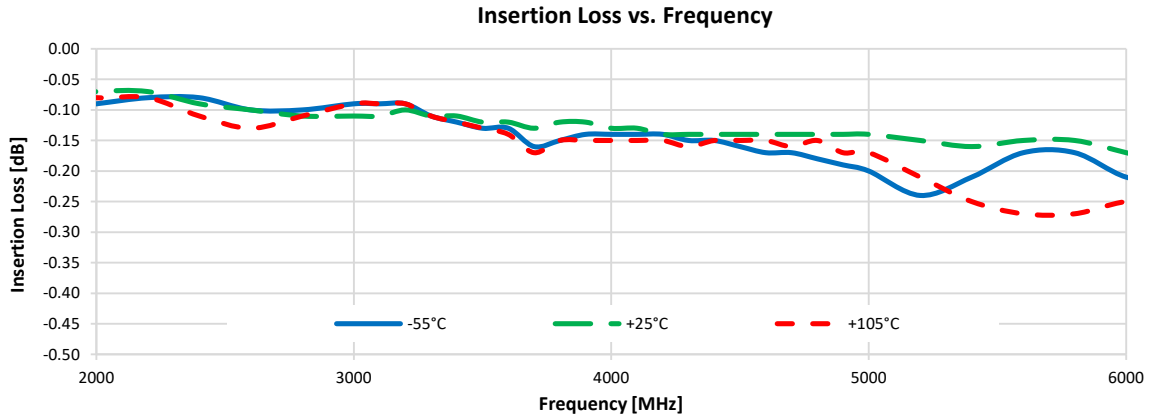

Bi-Directional Coupler

BDCH-20-63A+

Typical Performance Graphs

Test Conditions: Input Power = +5 dbm, Configuration B.

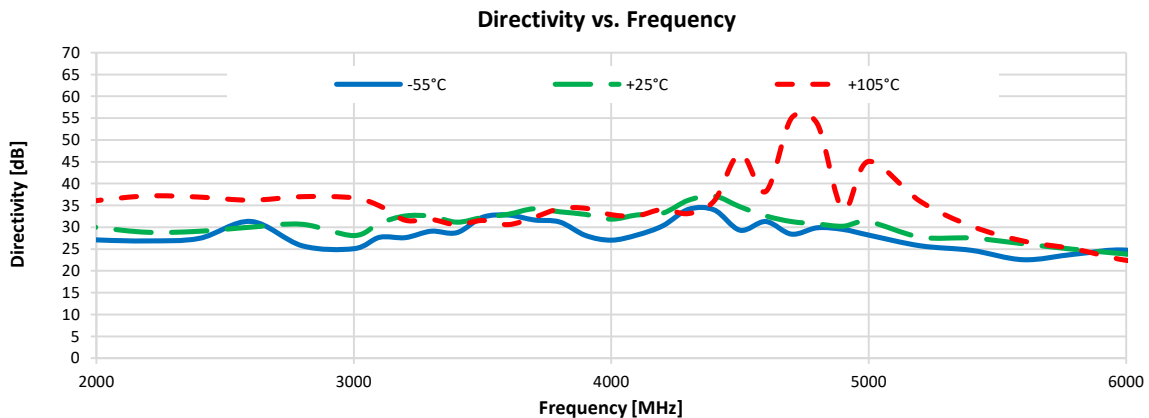
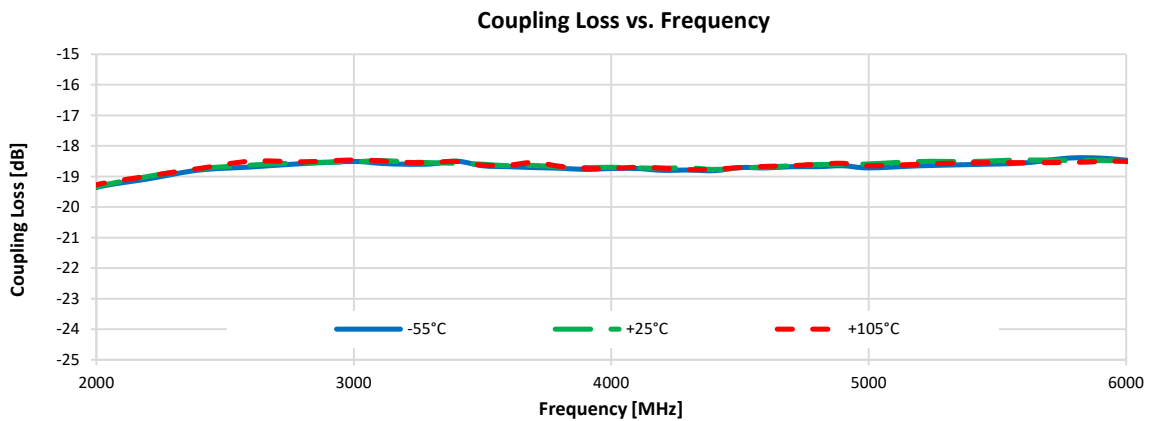
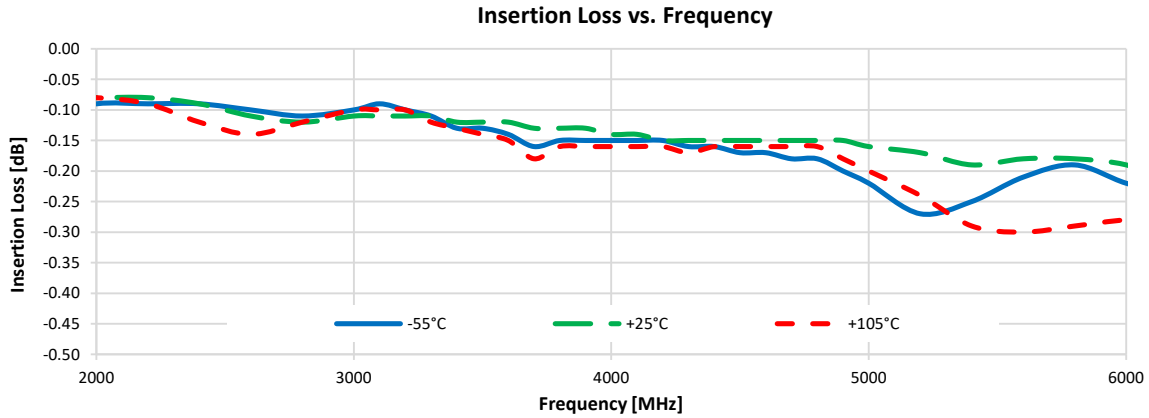

Typical Performance Graphs

Test Conditions: Input Power = +5 dbm, Configuration C.

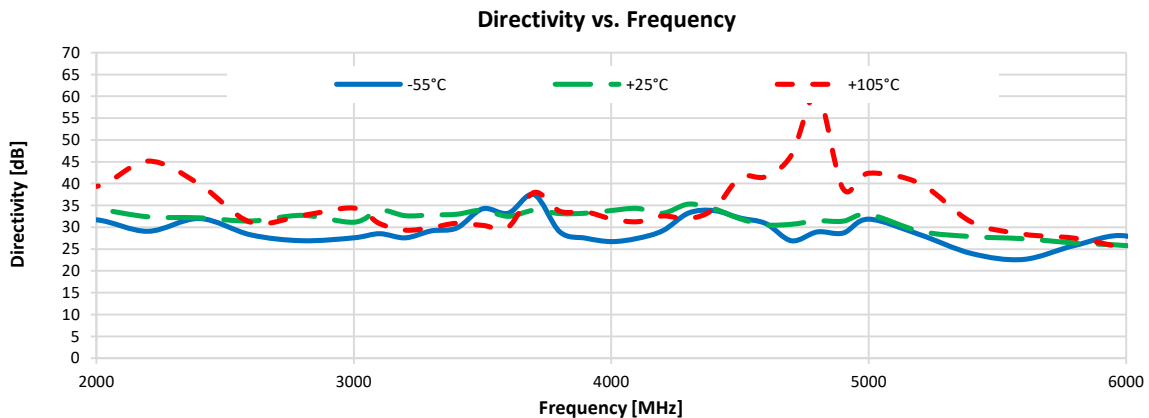
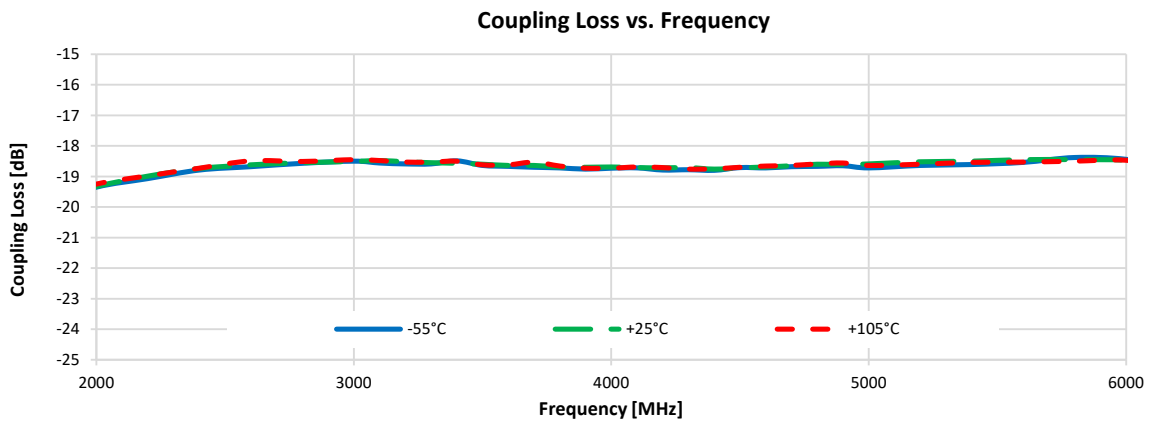
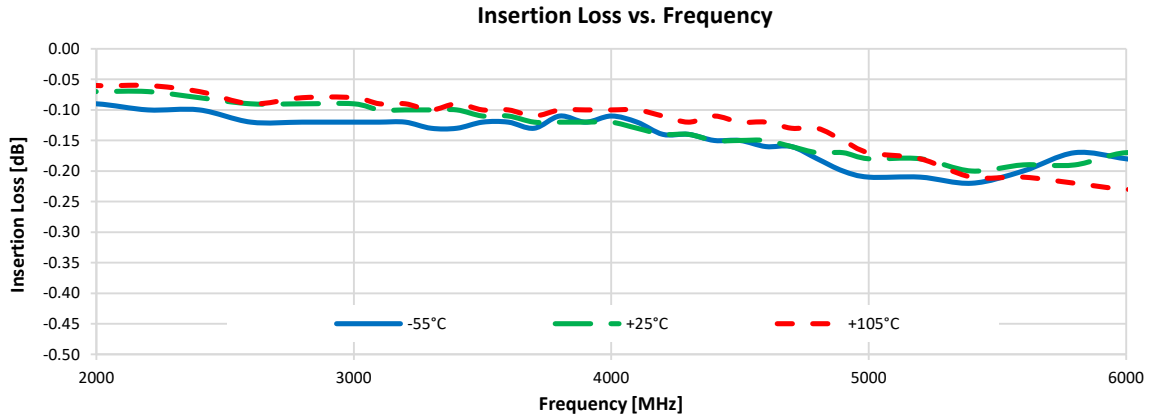

Bi-Directional Coupler

Typical Performance Graphs

Test Conditions: Input Power = +5 dbm, Configuration D.

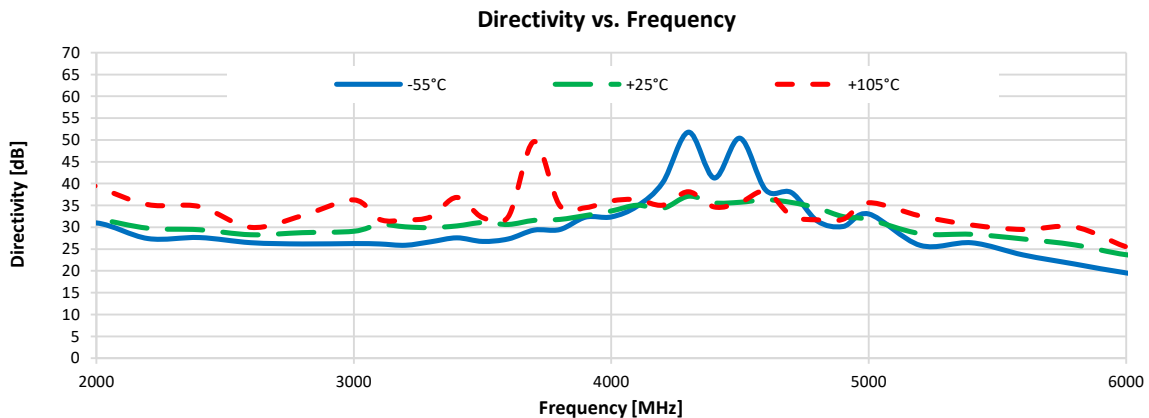
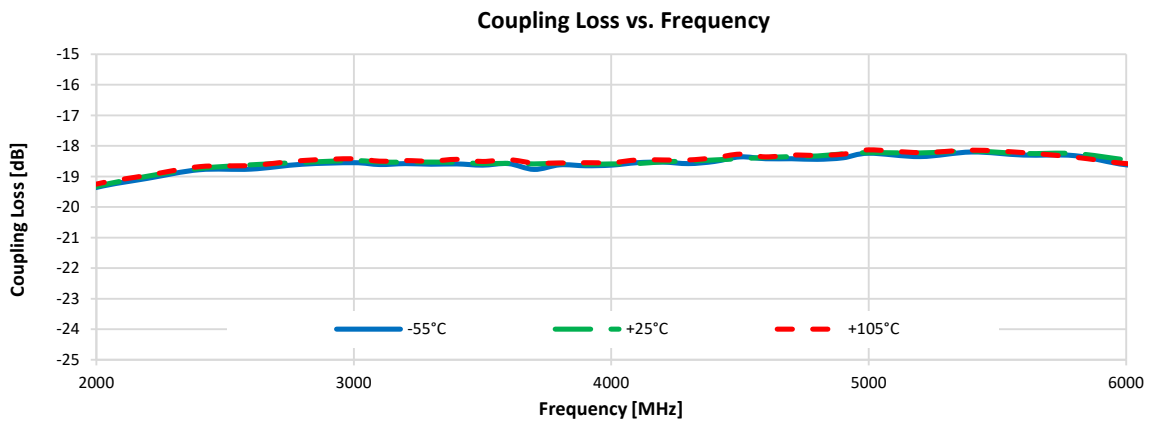
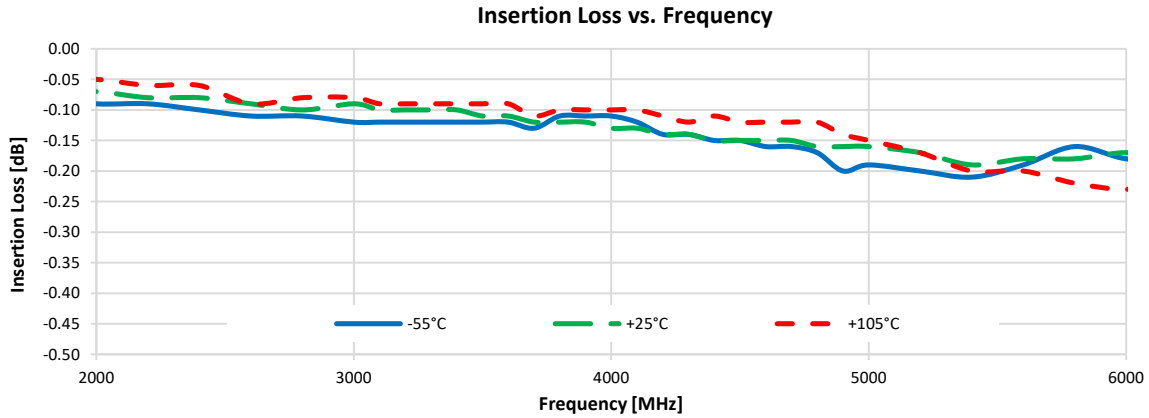

Typical Performance Graphs

Test Conditions: Input Power = +5 dbm, Configuration A.

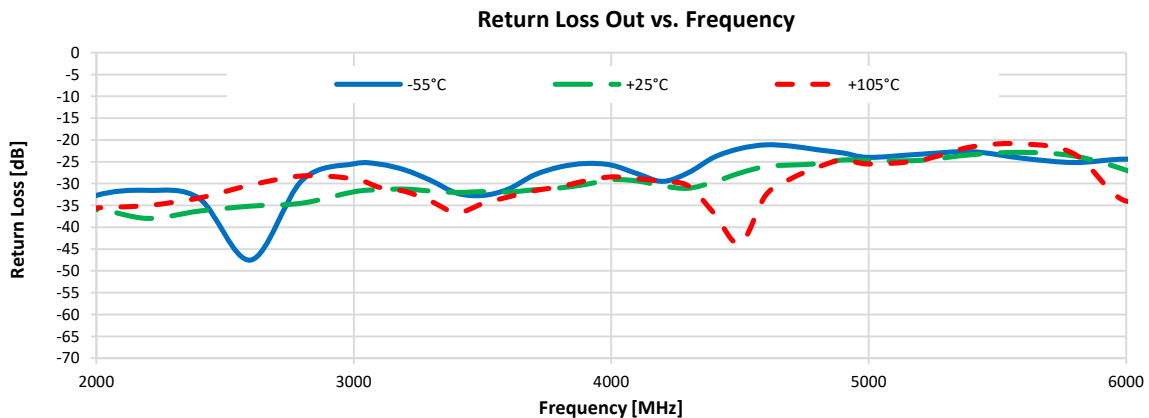
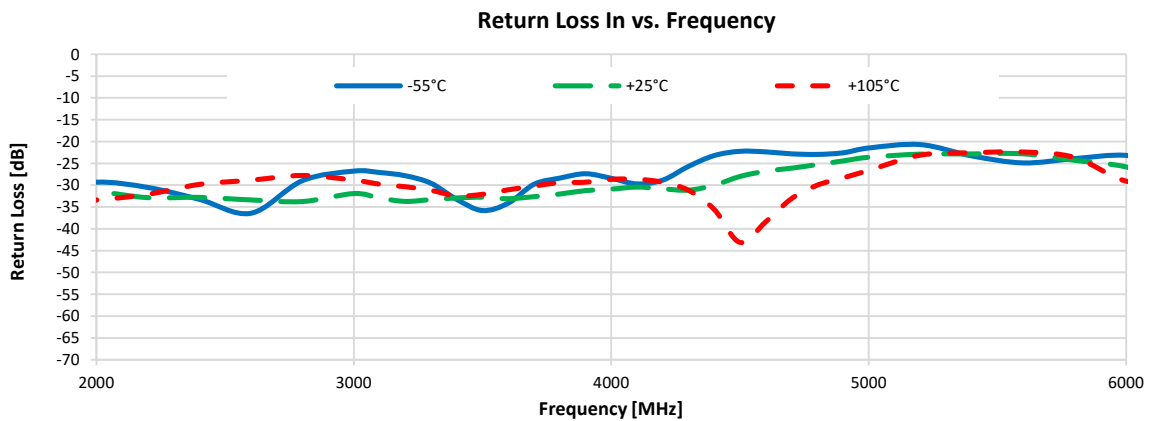
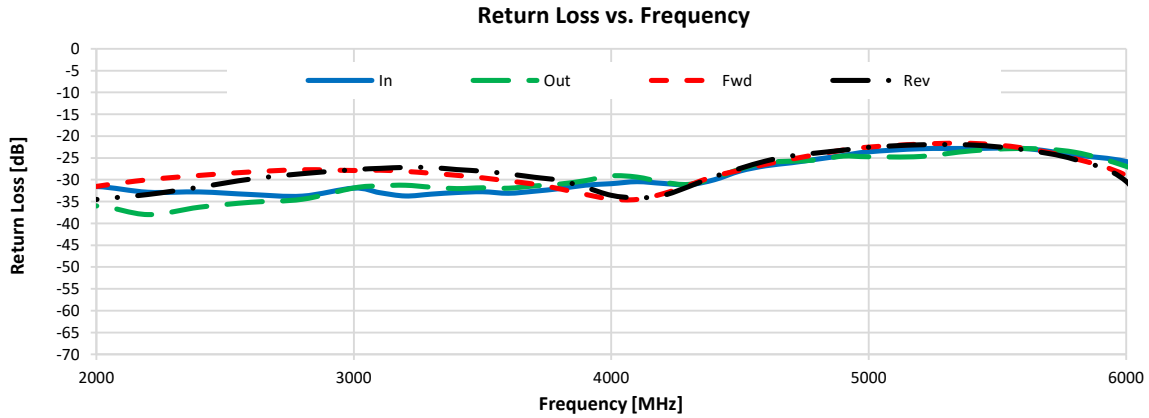

NOTES:

- A. Performance and quality attributes and conditions not expressly stated in this specification document are intended to be excluded and do not form a part of this specification document.
- B. Electrical specifications and performance data contained in this specification document are based on Mini-Circuit's applicable established test performance criteria and measurement instructions.
- C. The parts covered by this specification document are subject to Mini-Circuits standard limited warranty and terms and conditions (collectively, "Standard Terms"); Purchasers of this part are entitled to the rights and benefits contained therein. For a full statement of the Standard Terms and the exclusive rights and remedies thereunder, please visit Mini-Circuits' website at <https://www.minicircuits.com/terms/viewterm.html>



Typical Performance Graphs

Test Conditions: Input Power = +5 dbm, Configuration A.

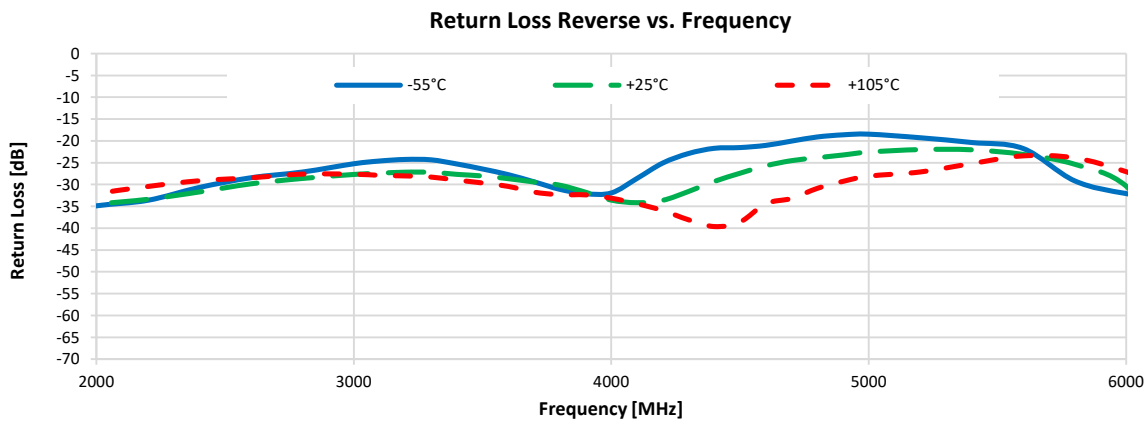
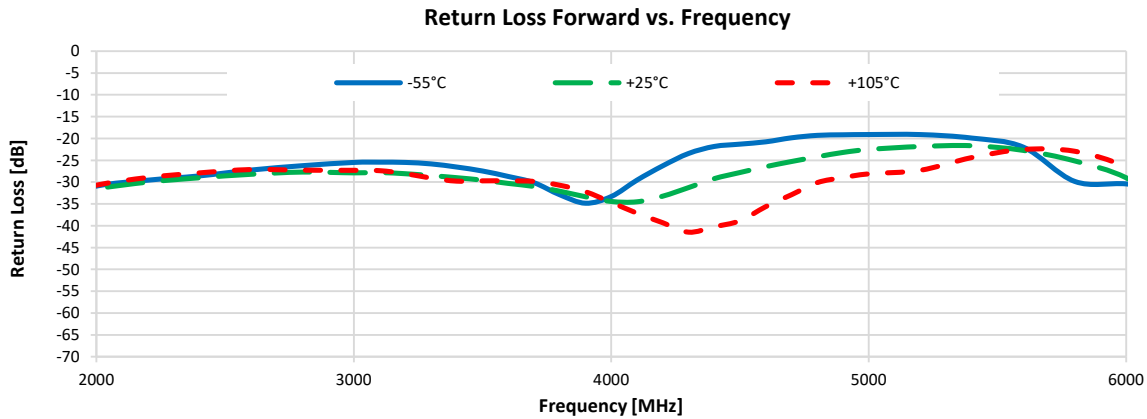

NOTES:

- A. Performance and quality attributes and conditions not expressly stated in this specification document are intended to be excluded and do not form a part of this specification document.
- B. Electrical specifications and performance data contained in this specification document are based on Mini-Circuit's applicable established test performance criteria and measurement instructions.
- C. The parts covered by this specification document are subject to Mini-Circuits standard limited warranty and terms and conditions (collectively, "Standard Terms"); Purchasers of this part are entitled to the parts and benefits contained therein. For a full statement of the Standard Terms and the exclusive rights and remedies thereunder, please visit Mini-Circuits' website at <https://www.minicircuits.com/terms/viewterm.html>



Case Style

PQ

Outline Dimensions

PQ2584

TOP SIDE

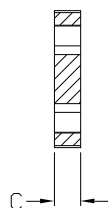
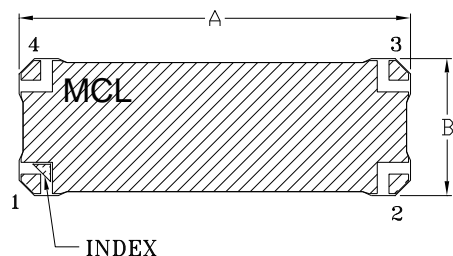

PCB LAND PATTERN

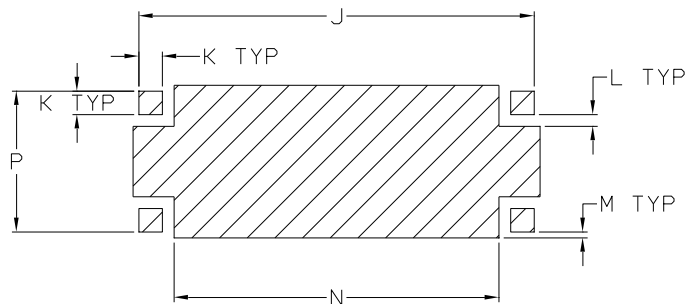

 METALLIZATION
  SOLDER RESIST

BOTTOM SIDE

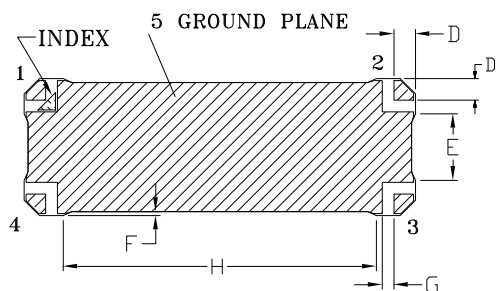

CASE#	A	B	C	D	E	F	G	H	J	K	L	M	N	P	WT. GRAMS
PQ2584	1.000 (25.40)	.350 (8.89)	.067 (1.70)	.055 (1.40)	.170 (4.32)	.010 (0.25)	.030 (0.76)	.800 (20.32)	1.010 (25.65)	.060 (1.52)	.030 (0.76)	.015 (0.38)	0.830 (21.08)	.360 (9.14)	2.0

Dimensions are in inches (mm). Tolerances: 2PL. +/- .03; 3PL. +/- .010

Notes:

1. Base material: Printed wiring laminate.
2. Termination finish:
 For RoHS Cases, all models (+) suffix: 2-5 μ inch (.05-.13 microns) Immersion Gold.
 For RoHS-5 Cases, all models no (+) suffix: Tin-Lead plate.



INTERNET <http://www.minicircuits.com>

P.O. Box 350166, Brooklyn, New York 11235-0003 (718) 934-4500 Fax (718) 332-4661

Distribution Centers NORTH AMERICA 800-654-7949 • 417-335-5935 • Fax 417-335-5945 • EUROPE 44-1252-832600 • Fax 44-1252-837010

Mini-Circuits ISO 9001 & ISO 14001 Certified

THIRD ANGLE PROJECTION

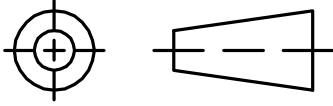

REVISIONS

REV	ECN No.	DESCRIPTION	DATE	DR	AUTH
OR	M166659	NEW RELEASE	04/18	DK	YB
OR	R93136	NEW RELEASE	04/18	DK	YB

SUGGESTED MOUNTING CONFIGURATION

FOR PQ2584 CASE STYLES 04DC01 PIN CONNECTION, 50 OHM

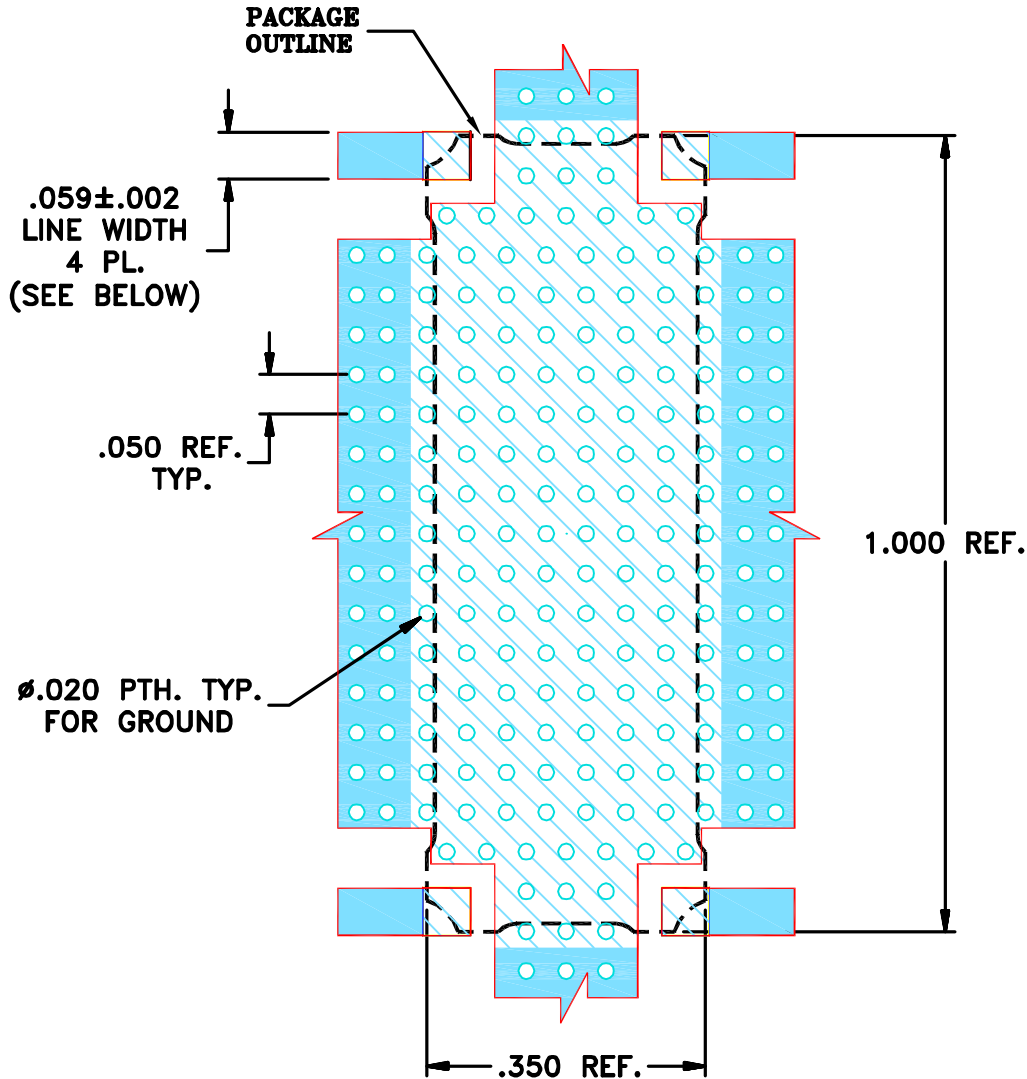

NOTES:

- TRACE WIDTH IS SHOWN FOR ROGERS RT/DUROID 5880 WITH DIELECTRIC THICKNESS. 0.020"±.0015". COPPER: 1 OZ. EACH SIDE. FOR OTHER MATERIALS TRACE WIDTH MAY NEED TO BE MODIFIED.
- BOTTOM SIDE OF THE PCB IS CONTINUOUS GROUND PLANE.

- DENOTES PCB COPPER LAYOUT WITH SMOBC (SOLDER MASK OVER BARE COPPER)
- DENOTES COPPER LAND PATTERN FREE OF SOLDERMASK

UNLESS OTHERWISE SPECIFIED	INITIALS	DATE
DIMENSIONS ARE IN INCHES TOLERANCES ON: 2 PL DECIMALS ± 3 PL DECIMALS ± .005 ANGLES ± 1° FRACTIONS ±	DRAWN	DK (RAYON) 13 APR 18
	CHECKED	RM (RAYON) 13 APR 18
	APPROVED	YB (RAYON) 13 APR 18



Mini-Circuits® 13 Neptune Avenue
Brooklyn NY 11235

PL FOR BDCH PQ2584
TB-1036+ (50 Ω)

Mini-Circuits®
THIS DOCUMENT AND ITS CONTENTS ARE THE PROPERTY OF MINI-CIRCUITS. EXCEPT FOR USE EXPRESSLY GRANTED, IN WRITING, TO ITS VENDORS, VENDOR AND THE UNITED STATES GOVERNMENT, MINI-CIRCUITS RESERVES ALL PROPRIETARY DESIGN, USE, MANUFACTURING AND REPRODUCTION RIGHTS THERETO. THESE CONTENTS SHALL NOT BE USED, DUPLICATED OR DISCLOSED TO ANY OUTSIDE PARTY, IN WHOLE OR IN PART, WITHOUT WRITTEN PERMISSION OF MINI-CIRCUITS.

SIZE A	CODE IDENT 15542	DRAWING NO: 98-PL-578	REV: OR
FILE: 98PL578(OR)		SCALE: 4:1	SHEET: 1 OF 1

Evaluation Board and Circuit

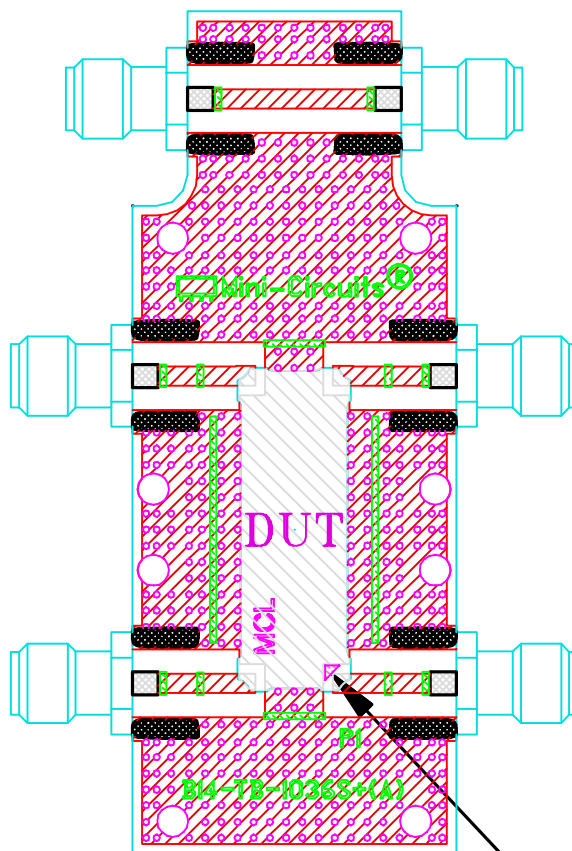

INDEX

TB-1036+

NOTES:

1. SMA FEMALE CONNECTORS.
2. PCB MATERIAL: ROGERS RT/DUROID 5880 OR EQUIVALENT,
DIELECTRIC CONSTANT=2.2,
DIELECTRIC THICKNESS=.020 INCH.

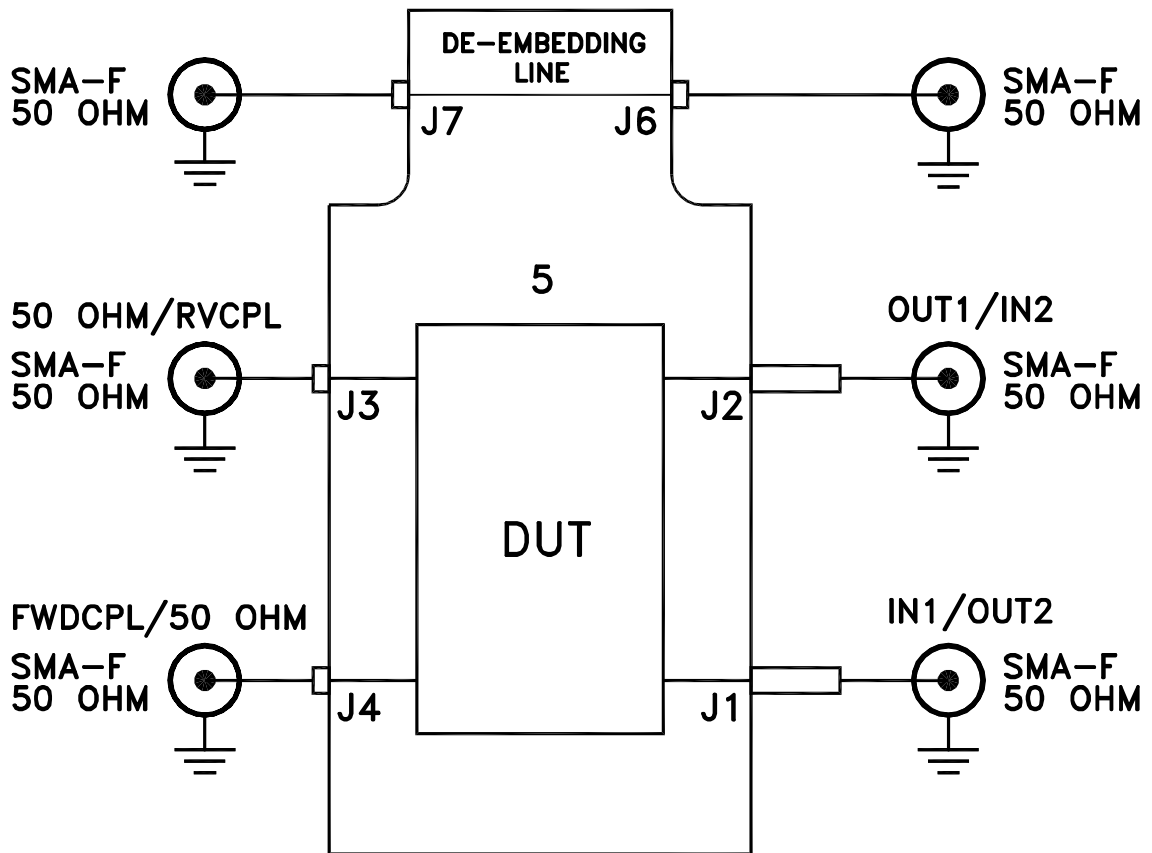

TB-1036+
Schematic Diagram



All Mini-Circuits products are manufactured under exacting quality assurance and control standards, and are capable of meeting published specifications after being subjected to any or all of the following physical and environmental test.

Specification	Test/Inspection Condition	Reference/Spec
Operating Temperature	-55° to 105° C Case Environment	Individual Model Data Sheet
Storage Temperature	-55° to 105°C Ambient Environment	Individual Model Data Sheet
Humidity	90 to 95% RH, 240 hours, 50°C	MIL-STD-202, Method 103, Condition A, Except 50°C and end-point electrical test done within 12 hours
Thermal Shock	-55° to 100°C, 100 cycles	MIL-STD-202, Method 107, Condition A-3, except +100°C
Solder Reflow Heat	Sn-Pb Eutectic Process 225°C peak Pb-Free Process 245° - 250°C peak	J-STD-020C, Table 4-1, 4-2 and 5-2, Figure 5-1
Solderability	10X Magnification	J-STD-002, Para 4.2.5, Test S, 95% Coverage
Vibration (high Frequency)	20g peak, 10-2000 Hz, 12 times in each of three perpendicular directions (total 36)	MIL-STD-883, Method 2007.3, Condition A
Mechanical Shock	50g, 11 ms, 1/2-sine, 18 shocks: 3 each direction, each of 3 axes	MIL-STD-202, Method 213, Condition A
Marking Resistance to Solvents	Isopropyl alcohol + mineral spirits at 25°C; terpene defluxer at 25°C; distilled water + proylene glycol monomethyl ether + monoethanolamine at 63°C to 70°C	MIL-STD-202, Method 215