



STRIPLINE SURFACE MOUNT

Bi-Directional Coupler

BDCH-15-272+

50Ω 700 to 2700 MHz 15 dB 150W

KEY FEATURES

- High power handling, up to 150W
- Excellent return loss, 24 dB Typ (all ports)
- Low insertion loss, 0.25 dB Typ



Generic photo used for illustration purposes only

APPLICATIONS

- VHF/UHF high power radio
- Transmission signal monitoring
- Antenna reflection monitoring
- Wireless transmitters
- Distributed antenna systems (DAS)

FUNCTIONAL DIAGRAM

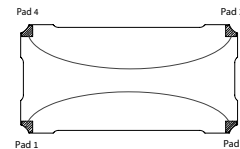

PRODUCT OVERVIEW

Mini-Circuits' BDCH-15-272+ is a high-power bi-directional coupler providing high power handling up to 150 W and insertion loss of 0.25 dB. High directivity of 19 dB provides accurate sampling from the coupled port, and 24 dB return loss provides excellent matching over full frequency range. Covering frequencies from 700 to 2700 MHz, the model supports a wide variety of applications from power amplifiers and antenna feeds to various digital communications and more. The coupler is designed into an open printed laminate (1.00" x 0.50" x 0.051") with wrap-around terminations for good solderability and easy visual inspection.

ELECTRICAL SPECIFICATIONS^{1,2} AT +25°C

Parameter	Frequency (MHz)	Min.	Typ.	Max.	Units
Frequency Range		700		2700	MHz
Insertion Loss ³	700-2700	-	0.25	0.35	dB
Coupling Nominal	700-2700	-	15±1	-	dB
Coupling Flatness (±)	700-2700	-	±1.4	-	dB
	800-2500	-	±0.6	-	
Directivity	700-2700	15	19	-	dB
Return Loss (Input/Output)	700-2700	19	24	-	dB
Return Loss (Coupled Forward/Reverse)	700-2700	19	24	-	dB
Thermal Resistance ⁴	700-2700	-	0.5	-	°C/W

1. Tested on Evaluation Board TB-BDCH-15-272+. De-embedded to the device reference plane.

2. Model is symmetrical and all ports are interchangeable, see Port Function Description/Configuration table for details and S-Parameters for actual performance.

3. Does not include theoretical loss due to coupling. Nominal theoretical loss is 0.14 dB.

4. Thermal Resistance is defined as, example (θ_{jc})= (Hot Spot Temperature on DUT - Base Plate Temperature)/Input Power)

ABSOLUTE MAXIMUM RATINGS⁵

Operating Case Temperature ⁶	-55 °C to +105 °C	
Storage Temperature	-55 °C to +105 °C	
Power Input	+85 °C case	150 W
	+95 °C case	120 W
	+105 °C case	90 W
DC Current	2.5 A	

5. Permanent damage may occur if any of these limits are exceeded.

6. Case temperature is defined as temperature on base plate.





TYPICAL PERFORMANCE GRAPHS

Note: Data corresponds to Configuration A at +25°C unless specified otherwise.

BDCH-15-272+

Insertion Loss vs. Frequency

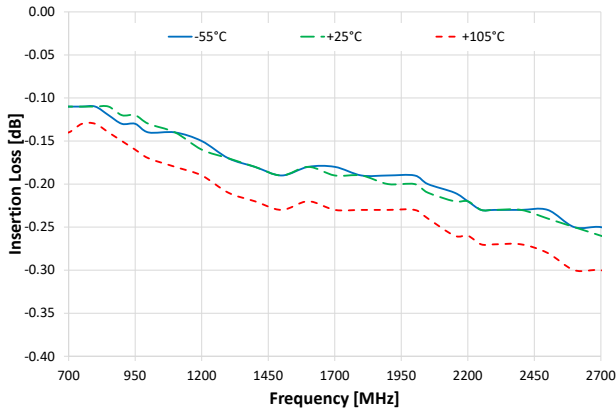

BDCH-15-272+

Coupling Loss vs. Frequency

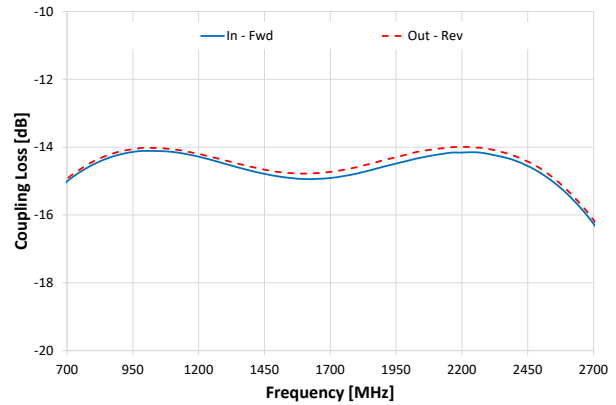

BDCH-15-272+

Directivity vs. Frequency

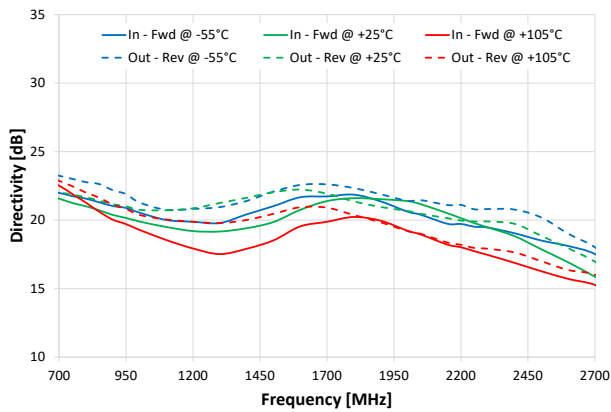

BDCH-15-272+

Return Loss vs. Frequency

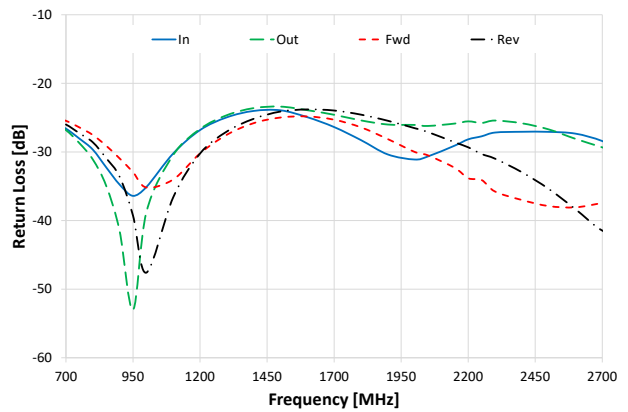



STRIPLINE SURFACE MOUNT

Bi-Directional Coupler

BDCH-15-272+

50Ω 700 to 2700 MHz 15 dB 150W

FUNCTIONAL DIAGRAM

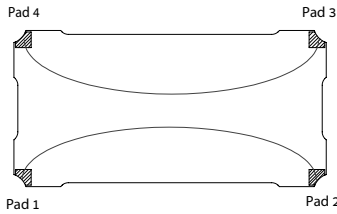

Figure 1. BDCH-15-272+ Functional Diagram

PAD DESCRIPTION/CONFIGURATION ⁷

Function	Pad Number	Description
Input	1	Connects to RF Input Port
Output	2	Connects to RF Output Port
Coupled Forward	4	Connects to Coupled Forward Port
Coupled Reverse	3	Connects to Coupled Reverse Port
Ground	5	Connects to Ground

Configuration	Input	Output	Coupled Forward	Coupled Reverse
A	1	2	4	3
B	2	1	3	4
C	3	4	2	1
D	4	3	1	2

7. Model is symmetrical and all ports are interchangeable, see Port Function Description/Configuration table for details and S-Parameters for actual performance.

SUGGESTED PCB LAYOUT (PL-538)

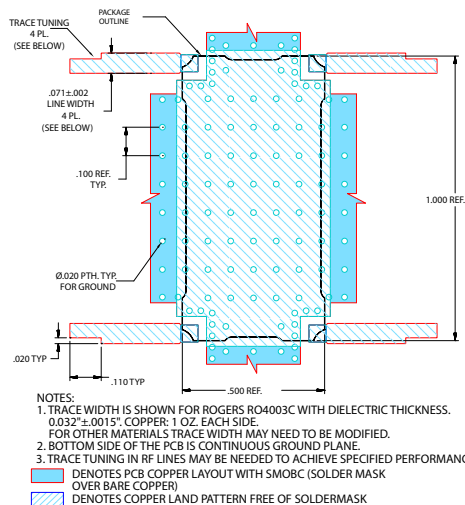
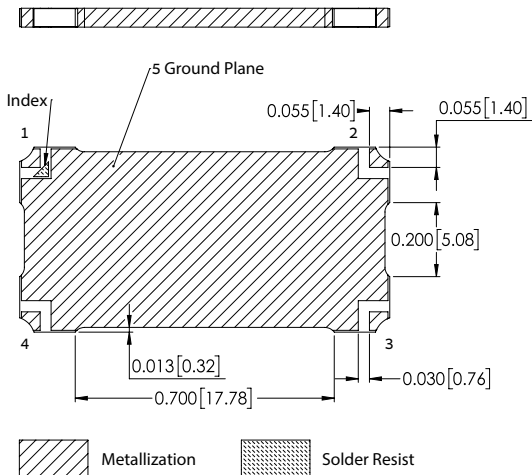
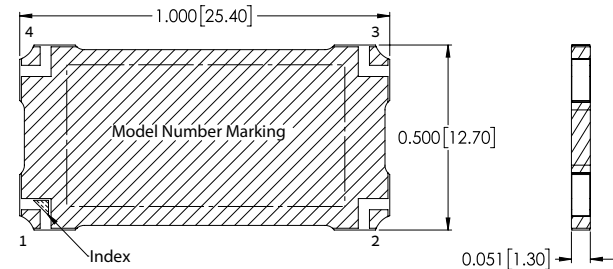

Figure 2. Suggested PCB Layout PL-538

CASE STYLE DRAWING (PQ2098)



NOTES:

- Base material: Printed wiring laminate.
- Termination finish: 2-5 μinch (.05-.13 microns) Immersion Gold.
- Weight: 2.0 grams
- Marking may contain other features or characters for internal lot control.

PRODUCT MARKING*: BDCH-15-272+

*Marking may contain other features or characters for internal lot control.



STRIPLINE SURFACE MOUNT

Bi-Directional Coupler

BDCH-15-272+

50Ω 700 to 2700 MHz 15 dB 150W

ADDITIONAL DETAILED INFORMATION IS AVAILABLE ON OUR DASH BOARD.

[CLICK HERE](#)

Performance Data & Graphs	Data
	Graphs
	S-Parameter (S4P Files) Data Set (.zip file) De-embedded to device pads
Case Style	PQ2098 Lead Finish: 2-5 inch (0.05-0.13 microns) Immersion Gold.
RoHS Status	Compliant
Tape and Reel	F118
Suggested Layout for PCB Design	PL-538
Evaluation Board	TB-BDCH-15-272+
	Gerber File
Environmental Rating	ENV02T8

NOTES

- A. Performance and quality attributes and conditions not expressly stated in this specification document are intended to be excluded and do not form a part of this specification document.
- B. Electrical specifications and performance data contained in this specification document are based on Mini-Circuits' applicable established test performance criteria and measurement instructions.
- C. The parts covered by this specification document are subject to Mini-Circuits' standard limited warranty and terms and conditions (collectively, "Standard Terms"); Purchasers of this part are entitled to the rights and benefits contained therein. For a full statement of the standard terms and the exclusive rights and remedies thereunder, please visit Mini-Circuits' website at www.minicircuits.com/terms/viewterm.html



Bi-Directional Coupler

Typical Performance Data

Test Conditions: Input Power = +5 dbm, Temperature = -55°C, Configuration A.

Freq. (MHz)	I. Loss (dB) In - Out	Coupling (dB)		Directivity (dB) In - Fwd	Return Loss (dB)			
		In - Fwd	Out - Rev		In	Out	Fwd	Rev
50	-0.06	-35.65	-35.67	30.68	-45.67	-44.38	-41.37	-44.75
100	-0.07	-29.69	-29.69	27.53	-34.65	-34.23	-34.57	-34.99
150	-0.08	-26.23	-26.24	25.41	-27.92	-27.71	-28.40	-28.76
250	-0.10	-22.03	-22.03	22.80	-22.60	-22.64	-23.61	-23.72
300	-0.11	-20.58	-20.58	22.34	-22.26	-22.25	-23.22	-23.28
350	-0.11	-19.39	-19.39	22.34	-22.73	-22.57	-23.39	-23.43
400	-0.11	-18.40	-18.40	22.35	-23.39	-23.19	-23.73	-23.88
450	-0.11	-17.57	-17.56	22.22	-23.95	-23.85	-24.25	-24.30
500	-0.11	-16.87	-16.86	22.30	-24.78	-24.89	-24.90	-25.16
550	-0.11	-16.28	-16.26	22.29	-25.57	-25.95	-25.74	-26.01
600	-0.11	-15.78	-15.76	22.29	-26.59	-27.01	-26.29	-26.85
650	-0.11	-15.40	-15.38	22.14	-27.89	-27.97	-26.60	-27.32
700	-0.11	-15.02	-14.99	21.99	-29.19	-28.92	-26.90	-27.79
750	-0.11	-14.74	-14.70	21.75	-30.99	-31.45	-27.75	-28.30
800	-0.11	-14.52	-14.46	21.57	-33.19	-35.89	-28.02	-29.33
850	-0.12	-14.35	-14.31	21.30	-36.29	-42.78	-29.85	-30.74
900	-0.13	-14.23	-14.19	21.03	-37.52	-57.34	-30.61	-33.19
950	-0.13	-14.16	-14.11	20.89	-36.51	-43.80	-34.06	-36.92
1000	-0.14	-14.12	-14.07	20.55	-34.83	-38.94	-34.07	-45.84
1100	-0.14	-14.15	-14.09	20.01	-30.74	-31.89	-32.93	-35.79
1200	-0.15	-14.29	-14.24	19.88	-26.99	-27.09	-28.70	-28.74
1300	-0.17	-14.47	-14.43	19.79	-24.86	-25.00	-25.73	-25.46
1400	-0.18	-14.69	-14.62	20.42	-24.29	-24.14	-24.12	-23.74
1500	-0.19	-14.85	-14.76	21.02	-23.91	-23.43	-23.80	-23.08
1600	-0.18	-14.92	-14.80	21.67	-24.37	-23.41	-24.22	-23.21
1700	-0.18	-14.88	-14.76	21.73	-25.27	-23.69	-25.34	-23.70
1800	-0.19	-14.76	-14.62	21.86	-27.34	-24.76	-27.50	-24.83
1900	-0.19	-14.56	-14.42	21.37	-29.68	-25.53	-30.23	-26.30
2000	-0.19	-14.38	-14.24	20.62	-30.05	-25.24	-33.61	-28.09
2050	-0.20	-14.29	-14.14	20.39	-29.20	-24.76	-35.68	-29.09
2150	-0.21	-14.17	-14.05	19.73	-27.16	-24.21	-41.40	-31.69
2200	-0.22	-14.15	-14.04	19.72	-25.95	-23.91	-42.19	-32.66
2250	-0.23	-14.15	-14.06	19.52	-25.30	-23.63	-41.93	-32.76
2300	-0.23	-14.20	-14.10	19.46	-24.57	-23.25	-39.30	-33.36
2400	-0.23	-14.40	-14.31	19.04	-24.11	-23.23	-37.75	-35.49
2500	-0.23	-14.78	-14.70	18.51	-24.32	-23.84	-36.42	-38.09
2600	-0.25	-15.37	-15.36	18.11	-25.72	-26.41	-33.80	-38.69
2700	-0.25	-16.26	-16.19	17.52	-28.35	-29.90	-33.04	-39.60
2800	-0.26	-17.48	-17.41	16.07	-31.67	-32.09	-34.27	-45.90
2900	-0.27	-19.20	-19.07	13.95	-32.94	-31.31	-36.13	-42.82
3000	-0.29	-21.73	-21.57	11.09	-32.74	-30.31	-34.35	-34.64

Bi-Directional Coupler

BDCH-15-272+

Typical Performance Data

Test Conditions: Input Power = +5 dbm, Temperature = -55°C, Configuration B.

Freq. (MHz)	I. Loss (dB) In - Out	Coupling (dB)		Directivity (dB) In - Fwd	Return Loss (dB)			
		In - Fwd	Out - Rev		In	Out	Fwd	Rev
50	-0.05	-35.67	-35.65	30.69	-44.38	-45.67	-44.75	-41.37
100	-0.07	-29.69	-29.69	28.12	-34.23	-34.65	-34.99	-34.57
150	-0.07	-26.24	-26.23	25.99	-27.71	-27.92	-28.76	-28.40
250	-0.10	-22.03	-22.03	23.70	-22.64	-22.60	-23.72	-23.61
300	-0.11	-20.58	-20.58	23.27	-22.25	-22.26	-23.28	-23.22
350	-0.10	-19.39	-19.39	23.22	-22.57	-22.73	-23.43	-23.39
400	-0.10	-18.40	-18.40	23.35	-23.19	-23.39	-23.88	-23.73
450	-0.10	-17.56	-17.57	23.32	-23.85	-23.95	-24.30	-24.25
500	-0.10	-16.86	-16.87	23.45	-24.89	-24.78	-25.16	-24.90
550	-0.11	-16.26	-16.28	23.51	-25.95	-25.57	-26.01	-25.74
600	-0.11	-15.76	-15.78	23.71	-27.01	-26.59	-26.85	-26.29
650	-0.11	-15.38	-15.40	23.48	-27.97	-27.89	-27.32	-26.60
700	-0.11	-14.99	-15.02	23.24	-28.92	-29.19	-27.79	-26.90
750	-0.11	-14.70	-14.74	23.01	-31.45	-30.99	-28.30	-27.75
800	-0.10	-14.46	-14.52	22.77	-35.89	-33.19	-29.33	-28.02
850	-0.11	-14.31	-14.35	22.63	-42.78	-36.29	-30.74	-29.85
900	-0.12	-14.19	-14.23	22.19	-57.34	-37.52	-33.19	-30.61
950	-0.13	-14.11	-14.16	21.90	-43.80	-36.51	-36.92	-34.06
1000	-0.13	-14.07	-14.12	21.29	-38.94	-34.83	-45.84	-34.07
1100	-0.14	-14.09	-14.15	20.75	-31.89	-30.74	-35.79	-32.93
1200	-0.15	-14.24	-14.29	20.82	-27.09	-26.99	-28.74	-28.70
1300	-0.16	-14.43	-14.47	20.95	-25.00	-24.86	-25.46	-25.73
1400	-0.18	-14.62	-14.69	21.40	-24.14	-24.29	-23.74	-24.12
1500	-0.18	-14.76	-14.85	22.08	-23.43	-23.91	-23.08	-23.80
1600	-0.17	-14.80	-14.92	22.57	-23.41	-24.37	-23.21	-24.22
1700	-0.17	-14.76	-14.88	22.61	-23.69	-25.27	-23.70	-25.34
1800	-0.17	-14.62	-14.76	22.34	-24.76	-27.34	-24.83	-27.50
1900	-0.17	-14.42	-14.56	21.89	-25.53	-29.68	-26.30	-30.23
2000	-0.18	-14.24	-14.38	21.41	-25.24	-30.05	-28.09	-33.61
2050	-0.18	-14.14	-14.29	21.46	-24.76	-29.20	-29.09	-35.68
2150	-0.20	-14.05	-14.17	21.10	-24.21	-27.16	-31.69	-41.40
2200	-0.22	-14.04	-14.15	21.11	-23.91	-25.95	-32.66	-42.19
2250	-0.22	-14.06	-14.15	20.79	-23.63	-25.30	-32.76	-41.93
2300	-0.23	-14.10	-14.20	20.81	-23.25	-24.57	-33.36	-39.30
2400	-0.23	-14.31	-14.40	20.77	-23.23	-24.11	-35.49	-37.75
2500	-0.24	-14.70	-14.78	20.19	-23.84	-24.32	-38.09	-36.42
2600	-0.27	-15.36	-15.37	19.01	-26.41	-25.72	-38.69	-33.80
2700	-0.27	-16.19	-16.26	18.02	-29.90	-28.35	-39.60	-33.04
2800	-0.28	-17.41	-17.48	16.45	-32.09	-31.67	-45.90	-34.27
2900	-0.29	-19.07	-19.20	14.10	-31.31	-32.94	-42.82	-36.13
3000	-0.30	-21.57	-21.73	11.07	-30.31	-32.74	-34.64	-34.35

Bi-Directional Coupler

BDCH-15-272+

Typical Performance Data

Test Conditions: Input Power = +5 dbm, Temperature = -55°C, Configuration C.

Freq. (MHz)	I. Loss (dB) In - Out	Coupling (dB)		Directivity (dB) In - Fwd	Return Loss (dB)			
		In - Fwd	Out - Rev		In	Out	Fwd	Rev
50	-0.05	-35.67	-35.67	30.52	-44.75	-41.37	-44.38	-45.67
100	-0.06	-29.70	-29.70	27.41	-34.99	-34.57	-34.23	-34.65
150	-0.06	-26.25	-26.25	25.32	-28.76	-28.40	-27.71	-27.92
250	-0.08	-22.04	-22.04	22.76	-23.72	-23.61	-22.64	-22.60
300	-0.09	-20.59	-20.60	22.36	-23.28	-23.22	-22.25	-22.26
350	-0.09	-19.40	-19.41	22.28	-23.43	-23.39	-22.57	-22.73
400	-0.09	-18.40	-18.42	22.39	-23.88	-23.73	-23.19	-23.39
450	-0.09	-17.57	-17.59	22.32	-24.30	-24.25	-23.85	-23.95
500	-0.09	-16.86	-16.89	22.38	-25.16	-24.90	-24.89	-24.78
550	-0.09	-16.27	-16.30	22.38	-26.01	-25.74	-25.95	-25.57
600	-0.09	-15.77	-15.80	22.38	-26.85	-26.29	-27.01	-26.59
650	-0.10	-15.39	-15.42	22.21	-27.32	-26.60	-27.97	-27.89
700	-0.10	-15.00	-15.04	22.03	-27.79	-26.90	-28.92	-29.19
750	-0.10	-14.71	-14.76	21.89	-28.30	-27.75	-31.45	-30.99
800	-0.10	-14.47	-14.54	21.61	-29.33	-28.02	-35.89	-33.19
850	-0.10	-14.32	-14.37	21.36	-30.74	-29.85	-42.78	-36.29
900	-0.11	-14.20	-14.25	21.10	-33.19	-30.61	-57.34	-37.52
950	-0.11	-14.12	-14.18	20.98	-36.92	-34.06	-43.80	-36.51
1000	-0.12	-14.08	-14.14	20.55	-45.84	-34.07	-38.94	-34.83
1100	-0.13	-14.10	-14.17	20.01	-35.79	-32.93	-31.89	-30.74
1200	-0.14	-14.24	-14.31	19.86	-28.74	-28.70	-27.09	-26.99
1300	-0.16	-14.44	-14.50	19.79	-25.46	-25.73	-25.00	-24.86
1400	-0.17	-14.63	-14.71	20.45	-23.74	-24.12	-24.14	-24.29
1500	-0.17	-14.77	-14.87	21.13	-23.08	-23.80	-23.43	-23.91
1600	-0.17	-14.81	-14.94	21.79	-23.21	-24.22	-23.41	-24.37
1700	-0.17	-14.77	-14.90	21.87	-23.70	-25.34	-23.69	-25.27
1800	-0.18	-14.63	-14.78	22.01	-24.83	-27.50	-24.76	-27.34
1900	-0.18	-14.43	-14.58	21.56	-26.30	-30.23	-25.53	-29.68
2000	-0.18	-14.25	-14.40	20.76	-28.09	-33.61	-25.24	-30.05
2050	-0.18	-14.15	-14.31	20.56	-29.09	-35.68	-24.76	-29.20
2150	-0.19	-14.06	-14.19	19.82	-31.69	-41.40	-24.21	-27.16
2200	-0.19	-14.04	-14.17	19.84	-32.66	-42.19	-23.91	-25.95
2250	-0.20	-14.07	-14.17	19.62	-32.76	-41.93	-23.63	-25.30
2300	-0.20	-14.11	-14.22	19.57	-33.36	-39.30	-23.25	-24.57
2400	-0.21	-14.32	-14.42	19.06	-35.49	-37.75	-23.23	-24.11
2500	-0.22	-14.70	-14.80	18.55	-38.09	-36.42	-23.84	-24.32
2600	-0.24	-15.36	-15.40	18.07	-38.69	-33.80	-26.41	-25.72
2700	-0.24	-16.19	-16.29	17.54	-39.60	-33.04	-29.90	-28.35
2800	-0.26	-17.40	-17.51	16.13	-45.90	-34.27	-32.09	-31.67
2900	-0.27	-19.07	-19.22	14.06	-42.82	-36.13	-31.31	-32.94
3000	-0.27	-21.57	-21.75	11.24	-34.64	-34.35	-30.31	-32.74

Bi-Directional Coupler

BDCH-15-272+

Typical Performance Data

Test Conditions: Input Power = +5 dbm, Temperature = -55°C, Configuration D.

Freq. (MHz)	I. Loss (dB) In - Out	Coupling (dB)		Directivity (dB) In - Fwd	Return Loss (dB)			
		In - Fwd	Out - Rev		In	Out	Fwd	Rev
50	-0.06	-35.67	-35.67	31.09	-41.37	-44.75	-45.67	-44.38
100	-0.08	-29.70	-29.70	28.09	-34.57	-34.99	-34.65	-34.23
150	-0.08	-26.25	-26.25	26.02	-28.40	-28.76	-27.92	-27.71
250	-0.10	-22.04	-22.04	23.58	-23.61	-23.72	-22.60	-22.64
300	-0.10	-20.60	-20.59	23.23	-23.22	-23.28	-22.26	-22.25
350	-0.11	-19.41	-19.40	23.15	-23.39	-23.43	-22.73	-22.57
400	-0.10	-18.42	-18.40	23.19	-23.73	-23.88	-23.39	-23.19
450	-0.11	-17.59	-17.57	23.23	-24.25	-24.30	-23.95	-23.85
500	-0.10	-16.89	-16.86	23.41	-24.90	-25.16	-24.78	-24.89
550	-0.11	-16.30	-16.27	23.46	-25.74	-26.01	-25.57	-25.95
600	-0.11	-15.80	-15.77	23.74	-26.29	-26.85	-26.59	-27.01
650	-0.12	-15.42	-15.39	23.48	-26.60	-27.32	-27.89	-27.97
700	-0.12	-15.04	-15.00	23.21	-26.90	-27.79	-29.19	-28.92
750	-0.12	-14.76	-14.71	22.96	-27.75	-28.30	-30.99	-31.45
800	-0.12	-14.54	-14.47	22.68	-28.02	-29.33	-33.19	-35.89
850	-0.13	-14.37	-14.32	22.52	-29.85	-30.74	-36.29	-42.78
900	-0.13	-14.25	-14.20	22.16	-30.61	-33.19	-37.52	-57.34
950	-0.13	-14.18	-14.12	21.86	-34.06	-36.92	-36.51	-43.80
1000	-0.14	-14.14	-14.08	21.28	-34.07	-45.84	-34.83	-38.94
1100	-0.15	-14.17	-14.10	20.65	-32.93	-35.79	-30.74	-31.89
1200	-0.17	-14.31	-14.24	20.62	-28.70	-28.74	-26.99	-27.09
1300	-0.18	-14.50	-14.44	20.80	-25.73	-25.46	-24.86	-25.00
1400	-0.19	-14.71	-14.63	21.31	-24.12	-23.74	-24.29	-24.14
1500	-0.20	-14.87	-14.77	21.95	-23.80	-23.08	-23.91	-23.43
1600	-0.20	-14.94	-14.81	22.40	-24.22	-23.21	-24.37	-23.41
1700	-0.21	-14.90	-14.77	22.44	-25.34	-23.70	-25.27	-23.69
1800	-0.21	-14.78	-14.63	22.25	-27.50	-24.83	-27.34	-24.76
1900	-0.20	-14.58	-14.43	21.77	-30.23	-26.30	-29.68	-25.53
2000	-0.21	-14.40	-14.25	21.11	-33.61	-28.09	-30.05	-25.24
2050	-0.21	-14.31	-14.15	21.22	-35.68	-29.09	-29.20	-24.76
2150	-0.21	-14.19	-14.06	20.99	-41.40	-31.69	-27.16	-24.21
2200	-0.22	-14.17	-14.04	21.03	-42.19	-32.66	-25.95	-23.91
2250	-0.22	-14.17	-14.07	20.73	-41.93	-32.76	-25.30	-23.63
2300	-0.22	-14.22	-14.11	20.69	-39.30	-33.36	-24.57	-23.25
2400	-0.23	-14.42	-14.32	20.51	-37.75	-35.49	-24.11	-23.23
2500	-0.24	-14.80	-14.70	20.19	-36.42	-38.09	-24.32	-23.84
2600	-0.26	-15.40	-15.36	19.26	-33.80	-38.69	-25.72	-26.41
2700	-0.27	-16.29	-16.19	17.92	-33.04	-39.60	-28.35	-29.90
2800	-0.28	-17.51	-17.40	16.16	-34.27	-45.90	-31.67	-32.09
2900	-0.29	-19.22	-19.07	13.93	-36.13	-42.82	-32.94	-31.31
3000	-0.30	-21.75	-21.57	11.03	-34.35	-34.64	-32.74	-30.31

Bi-Directional Coupler

BDCH-15-272+

Typical Performance Data

Test Conditions: Input Power = +5 dbm, Temperature = +25°C, Configuration A.

Freq. (MHz)	I. Loss (dB) In - Out	Coupling (dB)		Directivity (dB) In - Fwd	Return Loss (dB)			
		In - Fwd	Out - Rev		In	Out	Fwd	Rev
50	-0.05	-35.62	-35.61	31.95	-37.27	-37.36	-37.70	-37.69
100	-0.07	-29.66	-29.64	30.20	-32.10	-32.33	-32.40	-32.82
150	-0.07	-26.20	-26.18	29.03	-29.11	-29.16	-29.79	-29.78
250	-0.08	-21.97	-21.95	26.36	-25.63	-25.62	-26.27	-26.31
300	-0.09	-20.53	-20.51	25.30	-24.67	-24.69	-25.24	-25.32
350	-0.09	-19.35	-19.32	24.59	-24.06	-24.02	-24.55	-24.58
400	-0.10	-18.37	-18.34	23.90	-23.68	-23.67	-24.06	-24.18
450	-0.10	-17.55	-17.51	23.29	-23.45	-23.45	-23.88	-23.93
500	-0.10	-16.86	-16.81	22.84	-23.59	-23.57	-23.81	-23.93
550	-0.10	-16.27	-16.21	22.52	-23.95	-23.90	-23.95	-24.23
600	-0.11	-15.77	-15.71	22.11	-24.56	-24.54	-24.31	-24.55
650	-0.11	-15.39	-15.32	21.84	-25.58	-25.68	-24.89	-25.28
700	-0.11	-15.01	-14.93	21.57	-26.60	-26.82	-25.46	-26.00
750	-0.11	-14.73	-14.65	21.25	-28.05	-28.71	-26.42	-27.27
800	-0.11	-14.51	-14.42	21.01	-29.65	-31.08	-27.52	-28.58
850	-0.11	-14.34	-14.25	20.72	-32.24	-34.93	-29.09	-30.90
900	-0.12	-14.22	-14.13	20.38	-34.75	-41.50	-30.94	-33.60
950	-0.12	-14.14	-14.06	20.16	-36.40	-53.02	-32.94	-39.27
1000	-0.13	-14.11	-14.02	19.90	-35.11	-38.77	-35.18	-47.59
1100	-0.14	-14.14	-14.06	19.50	-30.22	-30.45	-34.01	-36.61
1200	-0.16	-14.28	-14.20	19.20	-26.81	-26.66	-30.22	-30.23
1300	-0.17	-14.49	-14.39	19.17	-24.95	-24.64	-27.49	-27.02
1400	-0.18	-14.70	-14.58	19.41	-24.02	-23.61	-25.80	-25.17
1500	-0.19	-14.86	-14.73	19.86	-23.93	-23.39	-24.98	-24.11
1600	-0.18	-14.94	-14.78	20.75	-24.93	-23.91	-24.82	-23.80
1700	-0.19	-14.91	-14.73	21.39	-26.37	-24.58	-25.30	-23.96
1800	-0.19	-14.78	-14.59	21.60	-28.27	-25.40	-26.41	-24.56
1900	-0.20	-14.58	-14.39	21.53	-30.36	-26.00	-28.12	-25.45
2000	-0.20	-14.39	-14.20	21.39	-31.10	-26.06	-29.99	-26.53
2050	-0.21	-14.30	-14.11	21.16	-30.65	-26.21	-30.50	-27.10
2150	-0.22	-14.17	-14.01	20.50	-29.07	-25.86	-32.32	-28.60
2200	-0.22	-14.16	-13.99	20.14	-28.16	-25.54	-33.83	-29.32
2250	-0.23	-14.15	-14.01	19.78	-27.72	-25.77	-34.09	-30.30
2300	-0.23	-14.20	-14.05	19.47	-27.17	-25.42	-35.77	-30.98
2400	-0.23	-14.39	-14.26	18.83	-27.06	-25.82	-37.00	-32.95
2500	-0.24	-14.77	-14.64	17.87	-27.07	-26.71	-37.89	-35.38
2600	-0.25	-15.38	-15.27	16.92	-27.33	-28.09	-38.07	-38.34
2700	-0.26	-16.26	-16.15	15.87	-28.41	-29.33	-37.44	-41.46
2800	-0.27	-17.47	-17.37	14.79	-30.29	-30.59	-36.81	-42.60
2900	-0.28	-19.17	-19.04	13.10	-31.53	-30.72	-36.53	-39.03
3000	-0.30	-21.65	-21.47	10.55	-30.98	-29.58	-33.90	-34.01

Bi-Directional Coupler

BDCH-15-272+

Typical Performance Data

Test Conditions: Input Power = +5 dbm, Temperature = +25°C, Configuration B.

Freq. (MHz)	I. Loss (dB) In - Out	Coupling (dB)		Directivity (dB) In - Fwd	Return Loss (dB)			
		In - Fwd	Out - Rev		In	Out	Fwd	Rev
50	-0.05	-35.61	-35.62	31.69	-37.36	-37.27	-37.69	-37.70
100	-0.06	-29.64	-29.66	30.15	-32.33	-32.10	-32.82	-32.40
150	-0.06	-26.18	-26.20	28.82	-29.16	-29.11	-29.78	-29.79
250	-0.07	-21.95	-21.97	26.30	-25.62	-25.63	-26.31	-26.27
300	-0.08	-20.51	-20.53	25.27	-24.69	-24.67	-25.32	-25.24
350	-0.09	-19.32	-19.35	24.53	-24.02	-24.06	-24.58	-24.55
400	-0.09	-18.34	-18.37	23.95	-23.67	-23.68	-24.18	-24.06
450	-0.09	-17.51	-17.55	23.48	-23.45	-23.45	-23.93	-23.88
500	-0.09	-16.81	-16.86	23.04	-23.57	-23.59	-23.93	-23.81
550	-0.10	-16.21	-16.27	22.73	-23.90	-23.95	-24.23	-23.95
600	-0.10	-15.71	-15.77	22.43	-24.54	-24.56	-24.55	-24.31
650	-0.10	-15.32	-15.39	22.23	-25.68	-25.58	-25.28	-24.89
700	-0.10	-14.93	-15.01	22.03	-26.82	-26.60	-26.00	-25.46
750	-0.10	-14.65	-14.73	21.86	-28.71	-28.05	-27.27	-26.42
800	-0.10	-14.42	-14.51	21.67	-31.08	-29.65	-28.58	-27.52
850	-0.10	-14.25	-14.34	21.42	-34.93	-32.24	-30.90	-29.09
900	-0.11	-14.13	-14.22	21.16	-41.50	-34.75	-33.60	-30.94
950	-0.11	-14.06	-14.14	21.01	-53.02	-36.40	-39.27	-32.94
1000	-0.12	-14.02	-14.11	20.75	-38.77	-35.11	-47.59	-35.18
1100	-0.14	-14.06	-14.14	20.72	-30.45	-30.22	-36.61	-34.01
1200	-0.15	-14.20	-14.28	20.86	-26.66	-26.81	-30.23	-30.22
1300	-0.16	-14.39	-14.49	21.25	-24.64	-24.95	-27.02	-27.49
1400	-0.17	-14.58	-14.70	21.63	-23.61	-24.02	-25.17	-25.80
1500	-0.18	-14.73	-14.86	22.04	-23.39	-23.93	-24.11	-24.98
1600	-0.17	-14.78	-14.94	22.23	-23.91	-24.93	-23.80	-24.82
1700	-0.17	-14.73	-14.91	21.93	-24.58	-26.37	-23.96	-25.30
1800	-0.17	-14.59	-14.78	21.37	-25.40	-28.27	-24.56	-26.41
1900	-0.17	-14.39	-14.58	20.96	-26.00	-30.36	-25.45	-28.12
2000	-0.18	-14.20	-14.39	20.67	-26.06	-31.10	-26.53	-29.99
2050	-0.19	-14.11	-14.30	20.46	-26.21	-30.65	-27.10	-30.50
2150	-0.20	-14.01	-14.17	20.14	-25.86	-29.07	-28.60	-32.32
2200	-0.20	-13.99	-14.16	19.97	-25.54	-28.16	-29.32	-33.83
2250	-0.21	-14.01	-14.15	19.90	-25.77	-27.72	-30.30	-34.09
2300	-0.21	-14.05	-14.20	19.90	-25.42	-27.17	-30.98	-35.77
2400	-0.22	-14.26	-14.39	19.73	-25.82	-27.06	-32.95	-37.00
2500	-0.23	-14.64	-14.77	18.85	-26.71	-27.07	-35.38	-37.89
2600	-0.25	-15.27	-15.38	17.95	-28.09	-27.33	-38.34	-38.07
2700	-0.26	-16.15	-16.26	16.97	-29.33	-28.41	-41.46	-37.44
2800	-0.28	-17.37	-17.47	15.63	-30.59	-30.29	-42.60	-36.81
2900	-0.29	-19.04	-19.17	13.62	-30.72	-31.53	-39.03	-36.53
3000	-0.29	-21.47	-21.65	10.92	-29.58	-30.98	-34.01	-33.90

Bi-Directional Coupler

BDCH-15-272+

Typical Performance Data

Test Conditions: Input Power = +5 dbm, Temperature = +25°C, Configuration C.

Freq. (MHz)	I. Loss (dB) In - Out	Coupling (dB)		Directivity (dB) In - Fwd	Return Loss (dB)			
		In - Fwd	Out - Rev		In	Out	Fwd	Rev
50	-0.05	-35.62	-35.61	31.55	-37.69	-37.70	-37.36	-37.27
100	-0.06	-29.65	-29.65	30.05	-32.82	-32.40	-32.33	-32.10
150	-0.06	-26.19	-26.19	28.91	-29.78	-29.79	-29.16	-29.11
250	-0.07	-21.96	-21.97	26.32	-26.31	-26.27	-25.62	-25.63
300	-0.07	-20.51	-20.53	25.34	-25.32	-25.24	-24.69	-24.67
350	-0.08	-19.33	-19.35	24.52	-24.58	-24.55	-24.02	-24.06
400	-0.08	-18.34	-18.37	23.95	-24.18	-24.06	-23.67	-23.68
450	-0.08	-17.52	-17.54	23.40	-23.93	-23.88	-23.45	-23.45
500	-0.08	-16.81	-16.85	22.93	-23.93	-23.81	-23.57	-23.59
550	-0.09	-16.22	-16.26	22.63	-24.23	-23.95	-23.90	-23.95
600	-0.09	-15.72	-15.76	22.23	-24.55	-24.31	-24.54	-24.56
650	-0.10	-15.33	-15.38	21.94	-25.28	-24.89	-25.68	-25.58
700	-0.10	-14.94	-15.00	21.65	-26.00	-25.46	-26.82	-26.60
750	-0.10	-14.65	-14.72	21.40	-27.27	-26.42	-28.71	-28.05
800	-0.10	-14.43	-14.50	21.06	-28.58	-27.52	-31.08	-29.65
850	-0.10	-14.25	-14.33	20.80	-30.90	-29.09	-34.93	-32.24
900	-0.11	-14.14	-14.21	20.46	-33.60	-30.94	-41.50	-34.75
950	-0.11	-14.06	-14.13	20.29	-39.27	-32.94	-53.02	-36.40
1000	-0.12	-14.02	-14.10	19.94	-47.59	-35.18	-38.77	-35.11
1100	-0.13	-14.06	-14.13	19.50	-36.61	-34.01	-30.45	-30.22
1200	-0.14	-14.20	-14.27	19.20	-30.23	-30.22	-26.66	-26.81
1300	-0.15	-14.39	-14.48	19.22	-27.02	-27.49	-24.64	-24.95
1400	-0.16	-14.58	-14.69	19.47	-25.17	-25.80	-23.61	-24.02
1500	-0.17	-14.73	-14.85	19.98	-24.11	-24.98	-23.39	-23.93
1600	-0.17	-14.78	-14.93	20.89	-23.80	-24.82	-23.91	-24.93
1700	-0.18	-14.73	-14.90	21.58	-23.96	-25.30	-24.58	-26.37
1800	-0.18	-14.59	-14.77	21.77	-24.56	-26.41	-25.40	-28.27
1900	-0.18	-14.40	-14.57	21.74	-25.45	-28.12	-26.00	-30.36
2000	-0.19	-14.21	-14.37	21.54	-26.53	-29.99	-26.06	-31.10
2050	-0.19	-14.12	-14.29	21.33	-27.10	-30.50	-26.21	-30.65
2150	-0.19	-14.02	-14.16	20.62	-28.60	-32.32	-25.86	-29.07
2200	-0.20	-13.99	-14.14	20.30	-29.32	-33.83	-25.54	-28.16
2250	-0.20	-14.01	-14.14	19.92	-30.30	-34.09	-25.77	-27.72
2300	-0.21	-14.05	-14.19	19.60	-30.98	-35.77	-25.42	-27.17
2400	-0.22	-14.26	-14.38	18.89	-32.95	-37.00	-25.82	-27.06
2500	-0.23	-14.64	-14.76	17.93	-35.38	-37.89	-26.71	-27.07
2600	-0.25	-15.26	-15.37	16.97	-38.34	-38.07	-28.09	-27.33
2700	-0.26	-16.15	-16.25	15.93	-41.46	-37.44	-29.33	-28.41
2800	-0.28	-17.36	-17.46	14.88	-42.60	-36.81	-30.59	-30.29
2900	-0.29	-19.03	-19.15	13.21	-39.03	-36.53	-30.72	-31.53
3000	-0.30	-21.46	-21.63	10.71	-34.01	-33.90	-29.58	-30.98

Bi-Directional Coupler

BDCH-15-272+

Typical Performance Data

Test Conditions: Input Power = +5 dbm, Temperature = +25°C, Configuration D.

Freq. (MHz)	I. Loss (dB) In - Out	Coupling (dB)		Directivity (dB) In - Fwd	Return Loss (dB)			
		In - Fwd	Out - Rev		In	Out	Fwd	Rev
50	-0.04	-35.61	-35.62	31.97	-37.70	-37.69	-37.27	-37.36
100	-0.06	-29.65	-29.65	30.02	-32.40	-32.82	-32.10	-32.33
150	-0.06	-26.19	-26.19	28.79	-29.79	-29.78	-29.11	-29.16
250	-0.06	-21.97	-21.96	26.14	-26.27	-26.31	-25.63	-25.62
300	-0.07	-20.53	-20.51	25.20	-25.24	-25.32	-24.67	-24.69
350	-0.08	-19.35	-19.33	24.46	-24.55	-24.58	-24.06	-24.02
400	-0.08	-18.37	-18.34	23.78	-24.06	-24.18	-23.68	-23.67
450	-0.08	-17.54	-17.52	23.37	-23.88	-23.93	-23.45	-23.45
500	-0.09	-16.85	-16.81	22.98	-23.81	-23.93	-23.59	-23.57
550	-0.09	-16.26	-16.22	22.64	-23.95	-24.23	-23.95	-23.90
600	-0.09	-15.76	-15.72	22.43	-24.31	-24.55	-24.56	-24.54
650	-0.10	-15.38	-15.33	22.21	-24.89	-25.28	-25.58	-25.68
700	-0.10	-15.00	-14.94	21.99	-25.46	-26.00	-26.60	-26.82
750	-0.10	-14.72	-14.65	21.79	-26.42	-27.27	-28.05	-28.71
800	-0.10	-14.50	-14.43	21.56	-27.52	-28.58	-29.65	-31.08
850	-0.11	-14.33	-14.25	21.31	-29.09	-30.90	-32.24	-34.93
900	-0.11	-14.21	-14.14	21.09	-30.94	-33.60	-34.75	-41.50
950	-0.11	-14.13	-14.06	20.96	-32.94	-39.27	-36.40	-53.02
1000	-0.12	-14.10	-14.02	20.70	-35.18	-47.59	-35.11	-38.77
1100	-0.13	-14.13	-14.06	20.59	-34.01	-36.61	-30.22	-30.45
1200	-0.15	-14.27	-14.20	20.65	-30.22	-30.23	-26.81	-26.66
1300	-0.16	-14.48	-14.39	21.06	-27.49	-27.02	-24.95	-24.64
1400	-0.17	-14.69	-14.58	21.50	-25.80	-25.17	-24.02	-23.61
1500	-0.18	-14.85	-14.73	21.87	-24.98	-24.11	-23.93	-23.39
1600	-0.19	-14.93	-14.78	22.04	-24.82	-23.80	-24.93	-23.91
1700	-0.19	-14.90	-14.73	21.73	-25.30	-23.96	-26.37	-24.58
1800	-0.19	-14.77	-14.59	21.24	-26.41	-24.56	-28.27	-25.40
1900	-0.19	-14.57	-14.40	20.77	-28.12	-25.45	-30.36	-26.00
2000	-0.20	-14.37	-14.21	20.36	-29.99	-26.53	-31.10	-26.06
2050	-0.20	-14.29	-14.12	20.21	-30.50	-27.10	-30.65	-26.21
2150	-0.20	-14.16	-14.02	20.01	-32.32	-28.60	-29.07	-25.86
2200	-0.21	-14.14	-13.99	19.86	-33.83	-29.32	-28.16	-25.54
2250	-0.21	-14.14	-14.01	19.78	-34.09	-30.30	-27.72	-25.77
2300	-0.22	-14.19	-14.05	19.73	-35.77	-30.98	-27.17	-25.42
2400	-0.23	-14.38	-14.26	19.47	-37.00	-32.95	-27.06	-25.82
2500	-0.24	-14.76	-14.64	18.86	-37.89	-35.38	-27.07	-26.71
2600	-0.25	-15.37	-15.26	18.08	-38.07	-38.34	-27.33	-28.09
2700	-0.26	-16.25	-16.15	16.80	-37.44	-41.46	-28.41	-29.33
2800	-0.28	-17.46	-17.36	15.35	-36.81	-42.60	-30.29	-30.59
2900	-0.29	-19.15	-19.03	13.53	-36.53	-39.03	-31.53	-30.72
3000	-0.30	-21.63	-21.46	10.87	-33.90	-34.01	-30.98	-29.58

Bi-Directional Coupler

BDCH-15-272+

Typical Performance Data

Test Conditions: Input Power = +5 dbm, Temperature = +105°C, Configuration A.

Freq. (MHz)	I. Loss (dB) In - Out	Coupling (dB)		Directivity (dB) In - Fwd	Return Loss (dB)			
		In - Fwd	Out - Rev		In	Out	Fwd	Rev
50	-0.07	-35.54	-35.54	33.03	-33.31	-33.37	-33.46	-33.57
100	-0.09	-29.59	-29.58	30.87	-29.94	-30.17	-30.15	-30.28
150	-0.09	-26.13	-26.13	30.08	-29.47	-29.55	-30.16	-30.00
250	-0.11	-21.90	-21.89	30.87	-30.14	-29.86	-31.05	-30.92
300	-0.11	-20.46	-20.45	30.15	-29.10	-28.84	-29.80	-29.87
350	-0.12	-19.28	-19.27	28.88	-27.53	-27.35	-28.34	-28.38
400	-0.12	-18.31	-18.29	26.85	-25.84	-25.75	-26.67	-26.89
450	-0.13	-17.49	-17.47	25.42	-25.02	-25.01	-25.76	-25.77
500	-0.13	-16.81	-16.77	24.45	-24.77	-24.63	-24.85	-25.01
550	-0.14	-16.23	-16.19	23.78	-24.97	-24.83	-24.54	-24.70
600	-0.14	-15.74	-15.68	23.33	-25.37	-25.25	-24.43	-24.69
650	-0.14	-15.37	-15.30	22.93	-25.76	-25.90	-24.66	-25.04
700	-0.14	-14.99	-14.91	22.52	-26.15	-26.54	-24.89	-25.38
750	-0.13	-14.71	-14.62	21.90	-26.23	-27.40	-25.48	-25.84
800	-0.13	-14.49	-14.39	21.28	-26.81	-28.42	-25.87	-26.72
850	-0.14	-14.33	-14.23	20.61	-28.15	-29.86	-26.86	-27.64
900	-0.15	-14.21	-14.11	20.04	-30.45	-32.05	-27.57	-29.31
950	-0.16	-14.14	-14.04	19.71	-32.48	-36.23	-29.30	-31.21
1000	-0.17	-14.10	-14.00	19.29	-35.73	-43.38	-30.26	-34.11
1100	-0.18	-14.14	-14.03	18.55	-38.33	-38.09	-32.79	-40.54
1200	-0.19	-14.28	-14.17	17.93	-31.13	-29.79	-32.54	-34.09
1300	-0.21	-14.48	-14.37	17.52	-26.20	-25.59	-28.92	-28.30
1400	-0.22	-14.70	-14.58	17.91	-24.15	-23.53	-26.04	-25.19
1500	-0.23	-14.88	-14.74	18.52	-23.12	-22.31	-24.24	-23.26
1600	-0.22	-14.95	-14.78	19.54	-22.96	-21.89	-23.36	-22.43
1700	-0.23	-14.91	-14.74	19.88	-23.10	-22.03	-23.36	-22.32
1800	-0.23	-14.78	-14.60	20.23	-24.54	-22.96	-24.13	-22.85
1900	-0.23	-14.58	-14.39	19.96	-26.40	-23.94	-25.50	-23.83
2000	-0.23	-14.38	-14.19	19.23	-27.78	-24.78	-27.45	-25.25
2050	-0.24	-14.28	-14.09	18.95	-27.94	-25.05	-27.88	-25.93
2150	-0.26	-14.16	-13.99	18.21	-27.84	-25.38	-30.31	-27.83
2200	-0.26	-14.14	-13.98	18.02	-27.46	-25.24	-32.96	-29.04
2250	-0.27	-14.15	-13.99	17.73	-27.23	-25.65	-33.33	-29.96
2300	-0.27	-14.20	-14.04	17.46	-26.78	-25.21	-36.96	-31.42
2400	-0.27	-14.40	-14.25	16.88	-26.49	-25.15	-39.18	-33.72
2500	-0.28	-14.79	-14.65	16.27	-26.08	-24.86	-37.32	-34.65
2600	-0.30	-15.43	-15.33	15.71	-26.47	-25.93	-34.85	-34.43
2700	-0.30	-16.33	-16.19	15.27	-27.71	-27.14	-33.18	-33.45
2800	-0.31	-17.59	-17.45	14.25	-29.23	-27.91	-32.16	-32.98
2900	-0.32	-19.37	-19.17	12.45	-29.82	-28.15	-31.71	-32.47
3000	-0.34	-21.98	-21.74	9.69	-29.97	-29.11	-30.39	-31.22

NOTES:

- A. Performance and quality attributes and conditions not expressly stated in this specification document are intended to be excluded and do not form a part of this specification document.
- B. Electrical specifications and performance data contained in this specification document are based on Mini-Circuit's applicable established test performance criteria and measurement instructions.
- C. The parts covered by this specification document are subject to Mini-Circuits standard limited warranty and terms and conditions (collectively, "Standard Terms"); Purchasers of this part are entitled to the rights and benefits contained therein. For a full statement of the Standard Terms and the exclusive rights and remedies thereunder, please visit Mini-Circuits' website at <https://www.minicircuits.com/terms/viewterm.html>



Bi-Directional Coupler

BDCH-15-272+

Typical Performance Data

Test Conditions: Input Power = +5 dbm, Temperature = +105°C, Configuration B.

Freq. (MHz)	I. Loss (dB) In - Out	Coupling (dB)		Directivity (dB) In - Fwd	Return Loss (dB)			
		In - Fwd	Out - Rev		In	Out	Fwd	Rev
50	-0.07	-35.54	-35.54	32.92	-33.37	-33.31	-33.57	-33.46
100	-0.09	-29.58	-29.59	31.00	-30.17	-29.94	-30.28	-30.15
150	-0.09	-26.13	-26.13	30.40	-29.55	-29.47	-30.00	-30.16
250	-0.10	-21.89	-21.90	30.32	-29.86	-30.14	-30.92	-31.05
300	-0.11	-20.45	-20.46	29.30	-28.84	-29.10	-29.87	-29.80
350	-0.11	-19.27	-19.28	27.94	-27.35	-27.53	-28.38	-28.34
400	-0.12	-18.29	-18.31	26.51	-25.75	-25.84	-26.89	-26.67
450	-0.13	-17.47	-17.49	25.49	-25.01	-25.02	-25.77	-25.76
500	-0.13	-16.77	-16.81	24.66	-24.63	-24.77	-25.01	-24.85
550	-0.13	-16.19	-16.23	23.97	-24.83	-24.97	-24.70	-24.54
600	-0.14	-15.68	-15.74	23.57	-25.25	-25.37	-24.69	-24.43
650	-0.14	-15.30	-15.37	23.22	-25.90	-25.76	-25.04	-24.66
700	-0.13	-14.91	-14.99	22.87	-26.54	-26.15	-25.38	-24.89
750	-0.13	-14.62	-14.71	22.47	-27.40	-26.23	-25.84	-25.48
800	-0.13	-14.39	-14.49	22.01	-28.42	-26.81	-26.72	-25.87
850	-0.14	-14.23	-14.33	21.64	-29.86	-28.15	-27.64	-26.86
900	-0.16	-14.11	-14.21	21.13	-32.05	-30.45	-29.31	-27.57
950	-0.16	-14.04	-14.14	20.82	-36.23	-32.48	-31.21	-29.30
1000	-0.17	-14.00	-14.10	20.38	-43.38	-35.73	-34.11	-30.26
1100	-0.17	-14.03	-14.14	20.05	-38.09	-38.33	-40.54	-32.79
1200	-0.18	-14.17	-14.28	19.88	-29.79	-31.13	-34.09	-32.54
1300	-0.20	-14.37	-14.48	19.78	-25.59	-26.20	-28.30	-28.92
1400	-0.22	-14.58	-14.70	20.01	-23.53	-24.15	-25.19	-26.04
1500	-0.22	-14.74	-14.88	20.46	-22.31	-23.12	-23.26	-24.24
1600	-0.22	-14.78	-14.95	20.94	-21.89	-22.96	-22.43	-23.36
1700	-0.22	-14.74	-14.91	20.91	-22.03	-23.10	-22.32	-23.36
1800	-0.23	-14.60	-14.78	20.37	-22.96	-24.54	-22.85	-24.13
1900	-0.23	-14.39	-14.58	19.84	-23.94	-26.40	-23.83	-25.50
2000	-0.23	-14.19	-14.38	19.20	-24.78	-27.78	-25.25	-27.45
2050	-0.23	-14.09	-14.28	19.00	-25.05	-27.94	-25.93	-27.88
2150	-0.25	-13.99	-14.16	18.36	-25.38	-27.84	-27.83	-30.31
2200	-0.26	-13.98	-14.14	18.20	-25.24	-27.46	-29.04	-32.96
2250	-0.26	-13.99	-14.15	17.97	-25.65	-27.23	-29.96	-33.33
2300	-0.27	-14.04	-14.20	17.91	-25.21	-26.78	-31.42	-36.96
2400	-0.27	-14.25	-14.40	17.64	-25.15	-26.49	-33.72	-39.18
2500	-0.29	-14.65	-14.79	17.00	-24.86	-26.08	-34.65	-37.32
2600	-0.31	-15.33	-15.43	16.36	-25.93	-26.47	-34.43	-34.85
2700	-0.32	-16.19	-16.33	16.02	-27.14	-27.71	-33.45	-33.18
2800	-0.34	-17.45	-17.59	14.88	-27.91	-29.23	-32.98	-32.16
2900	-0.34	-19.17	-19.37	12.77	-28.15	-29.82	-32.47	-31.71
3000	-0.36	-21.74	-21.98	9.91	-29.11	-29.97	-31.22	-30.39

NOTES:

- A. Performance and quality attributes and conditions not expressly stated in this specification document are intended to be excluded and do not form a part of this specification document.
- B. Electrical specifications and performance data contained in this specification document are based on Mini-Circuit's applicable established test performance criteria and measurement instructions.
- C. The parts covered by this specification document are subject to Mini-Circuits standard limited warranty and terms and conditions (collectively, "Standard Terms"); Purchasers of this part are entitled to the rights and benefits contained therein. For a full statement of the Standard Terms and the exclusive rights and remedies thereunder, please visit Mini-Circuits' website at <https://www.minicircuits.com/terms/viewterm.html>



Bi-Directional Coupler

BDCH-15-272+

Typical Performance Data

Test Conditions: Input Power = +5 dbm, Temperature = +105°C, Configuration C.

Freq. (MHz)	I. Loss (dB) In - Out	Coupling (dB)		Directivity (dB) In - Fwd	Return Loss (dB)			
		In - Fwd	Out - Rev		In	Out	Fwd	Rev
50	-0.05	-35.55	-35.54	32.66	-33.57	-33.46	-33.37	-33.31
100	-0.07	-29.59	-29.59	30.67	-30.28	-30.15	-30.17	-29.94
150	-0.07	-26.13	-26.13	30.00	-30.00	-30.16	-29.55	-29.47
250	-0.07	-21.89	-21.90	30.86	-30.92	-31.05	-29.86	-30.14
300	-0.08	-20.45	-20.46	30.20	-29.87	-29.80	-28.84	-29.10
350	-0.08	-19.27	-19.28	28.78	-28.38	-28.34	-27.35	-27.53
400	-0.09	-18.29	-18.31	26.91	-26.89	-26.67	-25.75	-25.84
450	-0.09	-17.47	-17.50	25.53	-25.77	-25.76	-25.01	-25.02
500	-0.10	-16.78	-16.81	24.55	-25.01	-24.85	-24.63	-24.77
550	-0.11	-16.18	-16.23	23.90	-24.70	-24.54	-24.83	-24.97
600	-0.11	-15.69	-15.74	23.46	-24.69	-24.43	-25.25	-25.37
650	-0.12	-15.31	-15.37	23.04	-25.04	-24.66	-25.90	-25.76
700	-0.12	-14.92	-14.99	22.62	-25.38	-24.89	-26.54	-26.15
750	-0.12	-14.62	-14.72	22.08	-25.84	-25.48	-27.40	-26.23
800	-0.12	-14.38	-14.50	21.38	-26.72	-25.87	-28.42	-26.81
850	-0.12	-14.23	-14.34	20.71	-27.64	-26.86	-29.86	-28.15
900	-0.13	-14.11	-14.22	20.15	-29.31	-27.57	-32.05	-30.45
950	-0.13	-14.03	-14.14	19.86	-31.21	-29.30	-36.23	-32.48
1000	-0.14	-14.00	-14.11	19.37	-34.11	-30.26	-43.38	-35.73
1100	-0.15	-14.02	-14.14	18.60	-40.54	-32.79	-38.09	-38.33
1200	-0.16	-14.17	-14.29	17.98	-34.09	-32.54	-29.79	-31.13
1300	-0.17	-14.38	-14.49	17.60	-28.30	-28.92	-25.59	-26.20
1400	-0.18	-14.59	-14.71	17.99	-25.19	-26.04	-23.53	-24.15
1500	-0.20	-14.74	-14.89	18.66	-23.26	-24.24	-22.31	-23.12
1600	-0.20	-14.78	-14.96	19.70	-22.43	-23.36	-21.89	-22.96
1700	-0.21	-14.73	-14.92	20.06	-22.32	-23.36	-22.03	-23.10
1800	-0.21	-14.59	-14.79	20.41	-22.85	-24.13	-22.96	-24.54
1900	-0.21	-14.39	-14.58	20.17	-23.83	-25.50	-23.94	-26.40
2000	-0.21	-14.19	-14.38	19.40	-25.25	-27.45	-24.78	-27.78
2050	-0.21	-14.10	-14.29	19.14	-25.93	-27.88	-25.05	-27.94
2150	-0.22	-13.99	-14.17	18.35	-27.83	-30.31	-25.38	-27.84
2200	-0.22	-13.97	-14.15	18.18	-29.04	-32.96	-25.24	-27.46
2250	-0.23	-14.00	-14.16	17.88	-29.96	-33.33	-25.65	-27.23
2300	-0.23	-14.03	-14.20	17.61	-31.42	-36.96	-25.21	-26.78
2400	-0.24	-14.24	-14.41	16.99	-33.72	-39.18	-25.15	-26.49
2500	-0.25	-14.64	-14.81	16.38	-34.65	-37.32	-24.86	-26.08
2600	-0.27	-15.32	-15.45	15.78	-34.43	-34.85	-25.93	-26.47
2700	-0.28	-16.18	-16.34	15.39	-33.45	-33.18	-27.14	-27.71
2800	-0.30	-17.44	-17.60	14.39	-32.98	-32.16	-27.91	-29.23
2900	-0.31	-19.15	-19.38	12.64	-32.47	-31.71	-28.15	-29.82
3000	-0.32	-21.72	-21.99	9.92	-31.22	-30.39	-29.11	-29.97

NOTES:

- A. Performance and quality attributes and conditions not expressly stated in this specification document are intended to be excluded and do not form a part of this specification document.
- B. Electrical specifications and performance data contained in this specification document are based on Mini-Circuit's applicable established test performance criteria and measurement instructions.
- C. The parts covered by this specification document are subject to Mini-Circuits standard limited warranty and terms and conditions (collectively, "Standard Terms"); Purchasers of this part are entitled to the rights and benefits contained therein. For a full statement of the Standard Terms and the exclusive rights and remedies thereunder, please visit Mini-Circuits' website at <https://www.minicircuits.com/terms/viewterm.html>



Bi-Directional Coupler

BDCH-15-272+

Typical Performance Data

Test Conditions: Input Power = +5 dbm, Temperature = +105°C, Configuration D.

Freq. (MHz)	I. Loss (dB) In - Out	Coupling (dB)		Directivity (dB) In - Fwd	Return Loss (dB)			
		In - Fwd	Out - Rev		In	Out	Fwd	Rev
50	-0.06	-35.54	-35.55	33.19	-33.46	-33.57	-33.31	-33.37
100	-0.08	-29.59	-29.59	30.65	-30.15	-30.28	-29.94	-30.17
150	-0.08	-26.13	-26.13	30.25	-30.16	-30.00	-29.47	-29.55
250	-0.08	-21.90	-21.89	30.08	-31.05	-30.92	-30.14	-29.86
300	-0.09	-20.46	-20.45	29.22	-29.80	-29.87	-29.10	-28.84
350	-0.09	-19.28	-19.27	27.84	-28.34	-28.38	-27.53	-27.35
400	-0.10	-18.31	-18.29	26.29	-26.67	-26.89	-25.84	-25.75
450	-0.10	-17.50	-17.47	25.38	-25.76	-25.77	-25.02	-25.01
500	-0.11	-16.81	-16.78	24.59	-24.85	-25.01	-24.77	-24.63
550	-0.12	-16.23	-16.18	23.90	-24.54	-24.70	-24.97	-24.83
600	-0.12	-15.74	-15.69	23.57	-24.43	-24.69	-25.37	-25.25
650	-0.13	-15.37	-15.31	23.19	-24.66	-25.04	-25.76	-25.90
700	-0.13	-14.99	-14.92	22.81	-24.89	-25.38	-26.15	-26.54
750	-0.13	-14.72	-14.62	22.38	-25.48	-25.84	-26.23	-27.40
800	-0.13	-14.50	-14.38	21.88	-25.87	-26.72	-26.81	-28.42
850	-0.14	-14.34	-14.23	21.50	-26.86	-27.64	-28.15	-29.86
900	-0.14	-14.22	-14.11	21.05	-27.57	-29.31	-30.45	-32.05
950	-0.15	-14.14	-14.03	20.75	-29.30	-31.21	-32.48	-36.23
1000	-0.15	-14.11	-14.00	20.31	-30.26	-34.11	-35.73	-43.38
1100	-0.16	-14.14	-14.02	19.88	-32.79	-40.54	-38.33	-38.09
1200	-0.17	-14.29	-14.17	19.65	-32.54	-34.09	-31.13	-29.79
1300	-0.19	-14.49	-14.38	19.59	-28.92	-28.30	-26.20	-25.59
1400	-0.20	-14.71	-14.59	19.87	-26.04	-25.19	-24.15	-23.53
1500	-0.22	-14.89	-14.74	20.28	-24.24	-23.26	-23.12	-22.31
1600	-0.22	-14.96	-14.78	20.72	-23.36	-22.43	-22.96	-21.89
1700	-0.23	-14.92	-14.73	20.72	-23.36	-22.32	-23.10	-22.03
1800	-0.23	-14.79	-14.59	20.24	-24.13	-22.85	-24.54	-22.96
1900	-0.23	-14.58	-14.39	19.66	-25.50	-23.83	-26.40	-23.94
2000	-0.23	-14.38	-14.19	18.90	-27.45	-25.25	-27.78	-24.78
2050	-0.23	-14.29	-14.10	18.75	-27.88	-25.93	-27.94	-25.05
2150	-0.24	-14.17	-13.99	18.19	-30.31	-27.83	-27.84	-25.38
2200	-0.24	-14.15	-13.97	18.08	-32.96	-29.04	-27.46	-25.24
2250	-0.24	-14.16	-14.00	17.81	-33.33	-29.96	-27.23	-25.65
2300	-0.25	-14.20	-14.03	17.72	-36.96	-31.42	-26.78	-25.21
2400	-0.26	-14.41	-14.24	17.38	-39.18	-33.72	-26.49	-25.15
2500	-0.27	-14.81	-14.64	16.99	-37.32	-34.65	-26.08	-24.86
2600	-0.29	-15.45	-15.32	16.41	-34.85	-34.43	-26.47	-25.93
2700	-0.30	-16.34	-16.18	15.77	-33.18	-33.45	-27.71	-27.14
2800	-0.31	-17.60	-17.44	14.59	-32.16	-32.98	-29.23	-27.91
2900	-0.32	-19.38	-19.15	12.63	-31.71	-32.47	-29.82	-28.15
3000	-0.33	-21.99	-21.72	9.77	-30.39	-31.22	-29.97	-29.11

NOTES:

- A. Performance and quality attributes and conditions not expressly stated in this specification document are intended to be excluded and do not form a part of this specification document.
- B. Electrical specifications and performance data contained in this specification document are based on Mini-Circuit's applicable established test performance criteria and measurement instructions.
- C. The parts covered by this specification document are subject to Mini-Circuits standard limited warranty and terms and conditions (collectively, "Standard Terms"); Purchasers of this part are entitled to the rights and benefits contained therein. For a full statement of the Standard Terms and the exclusive rights and remedies thereunder, please visit Mini-Circuits' website at <https://www.minicircuits.com/terms/viewterm.html>



Bi-Directional Coupler

BDCH-15-272+

Typical Performance Graphs

Test Conditions: Input Power = +5 dbm, Configuration A.

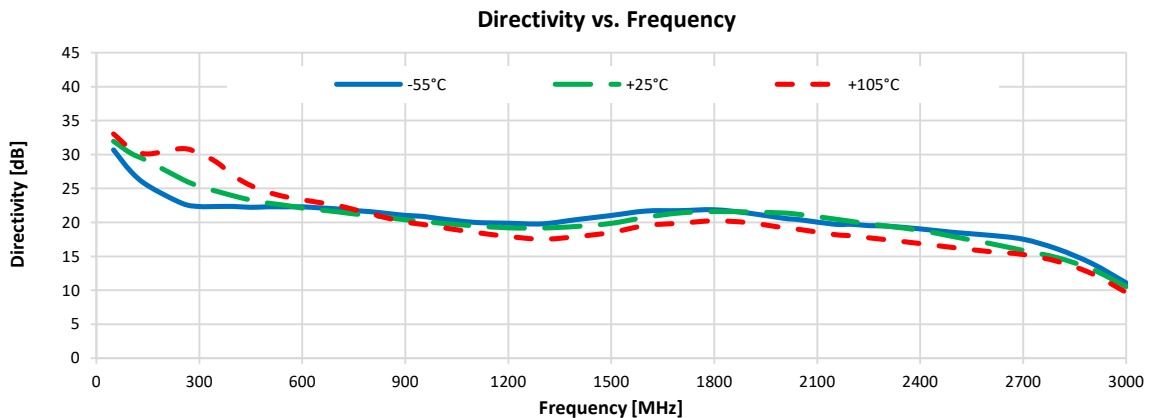
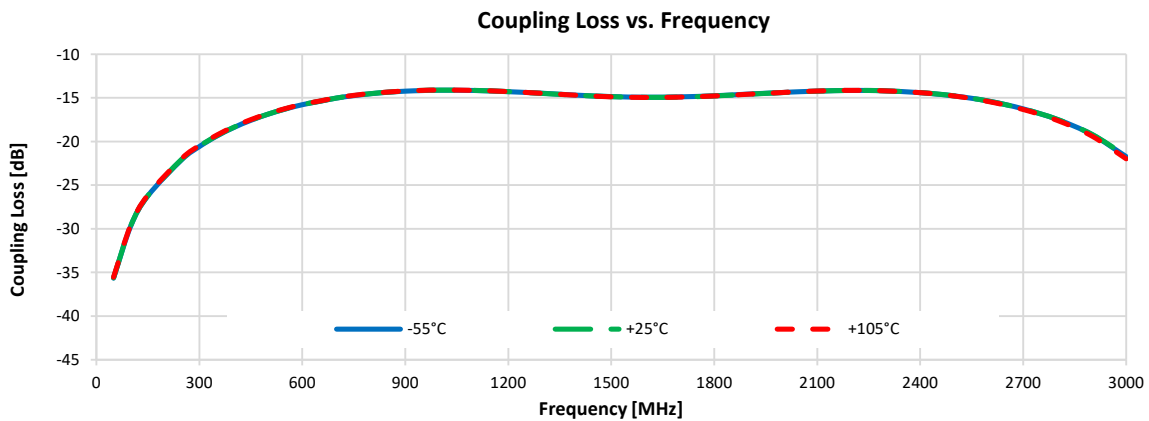
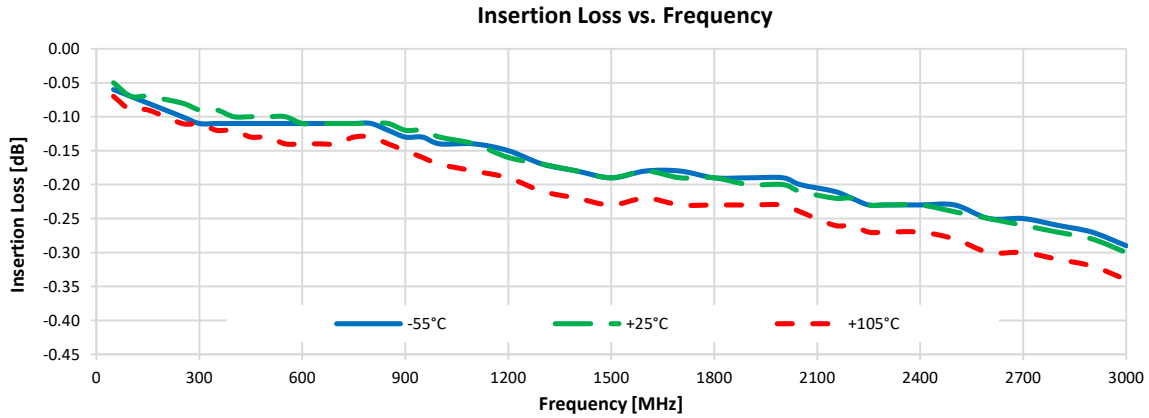

Bi-Directional Coupler

BDCH-15-272+

Typical Performance Graphs

Test Conditions: Input Power = +5 dbm, Configuration B.

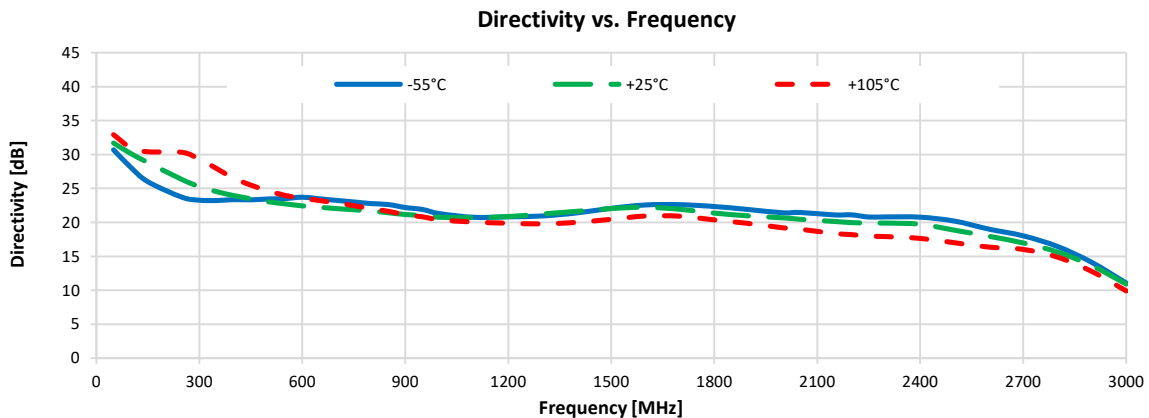
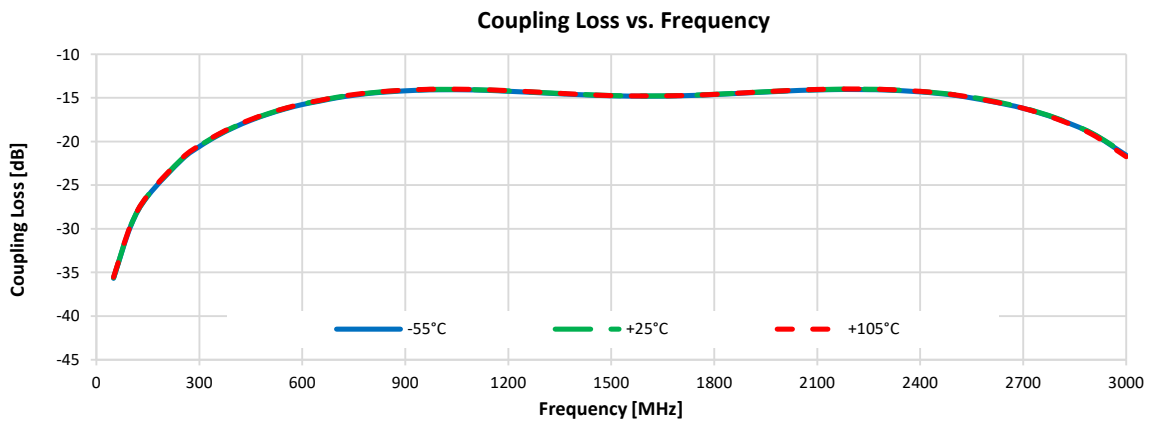
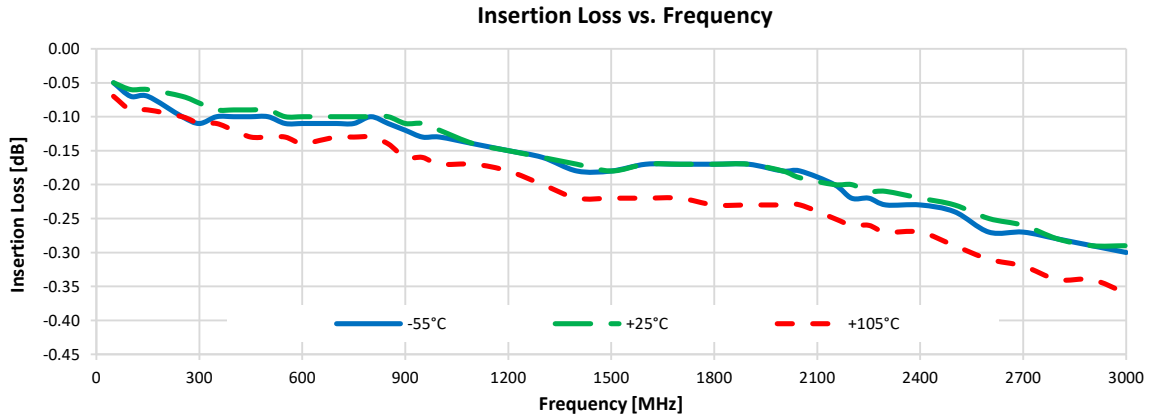

Bi-Directional Coupler

BDCH-15-272+

Typical Performance Graphs

Test Conditions: Input Power = +5 dbm, Configuration C.

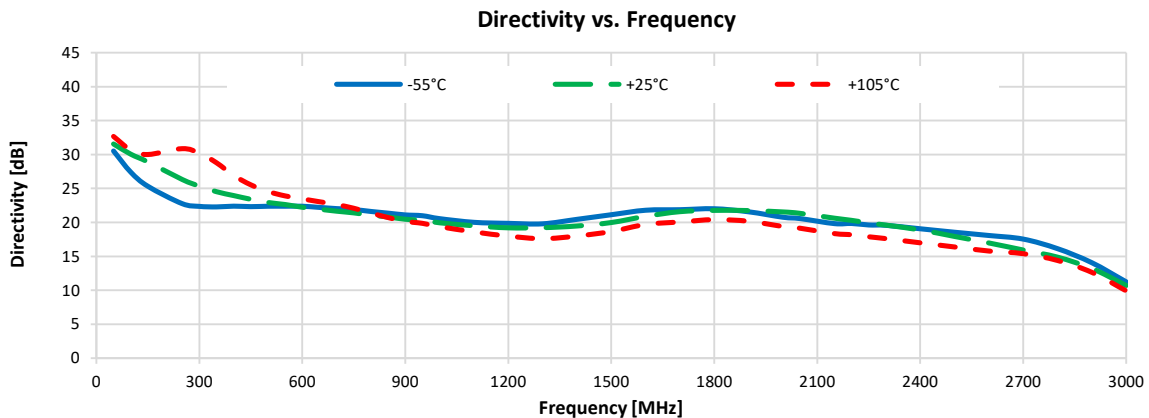
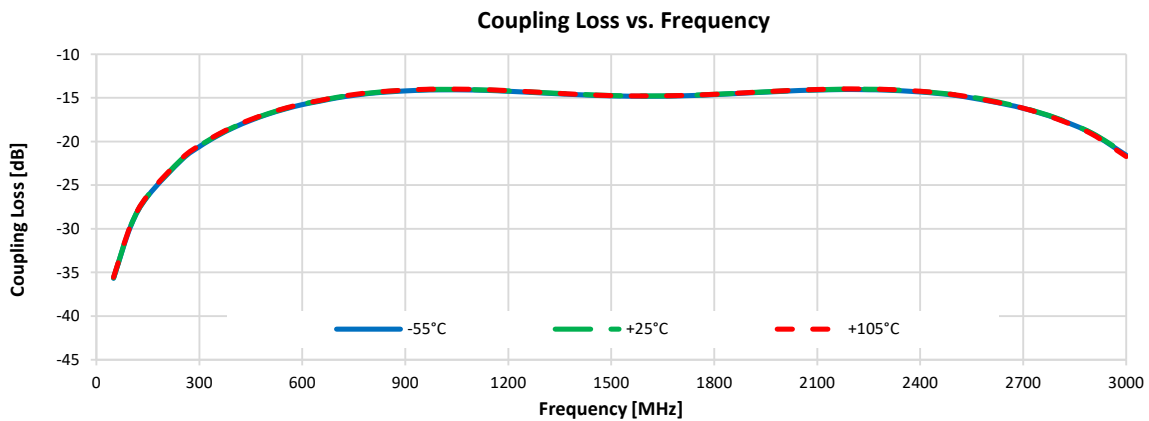
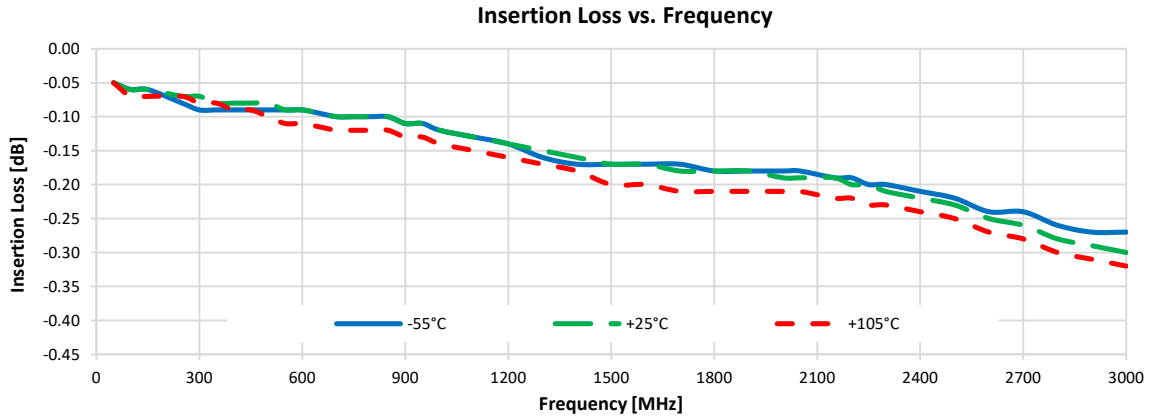

Bi-Directional Coupler

BDCH-15-272+

Typical Performance Graphs

Test Conditions: Input Power = +5 dbm, Configuration D.

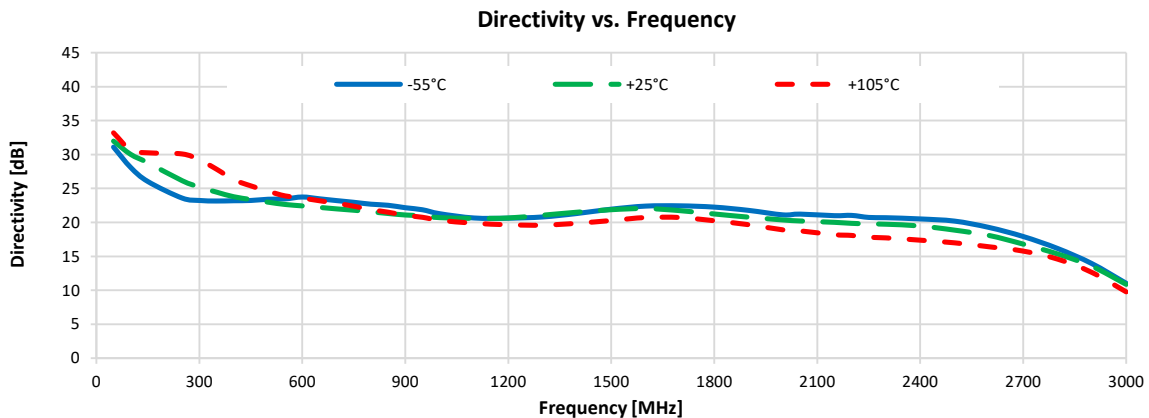
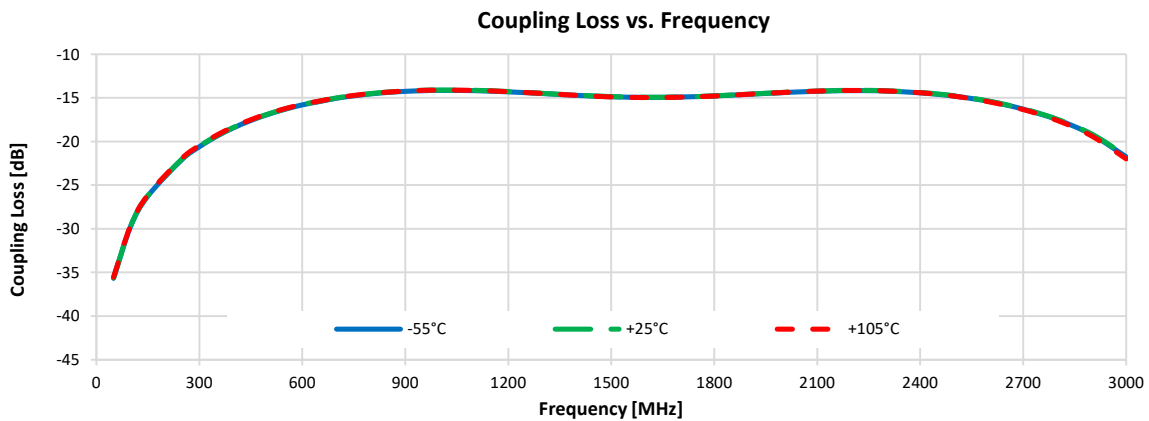
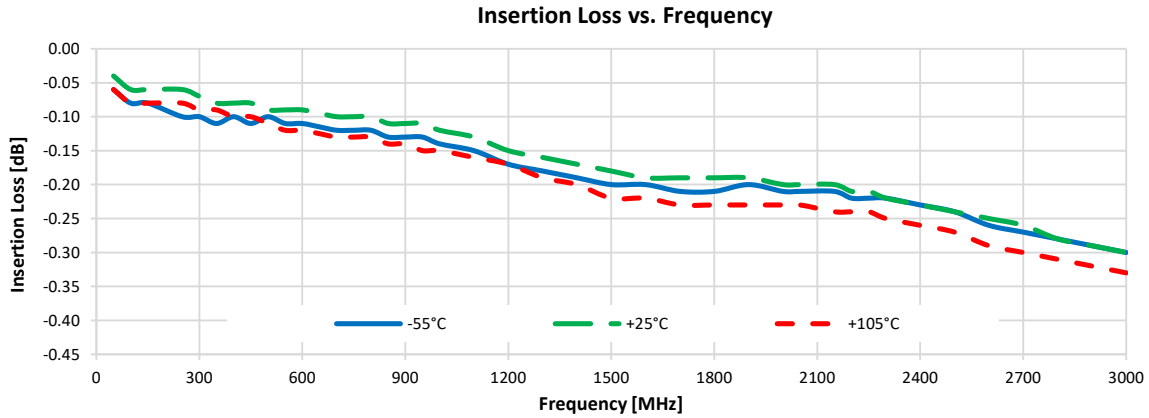

Typical Performance Graphs

Test Conditions: Input Power = +5 dbm, Configuration A.

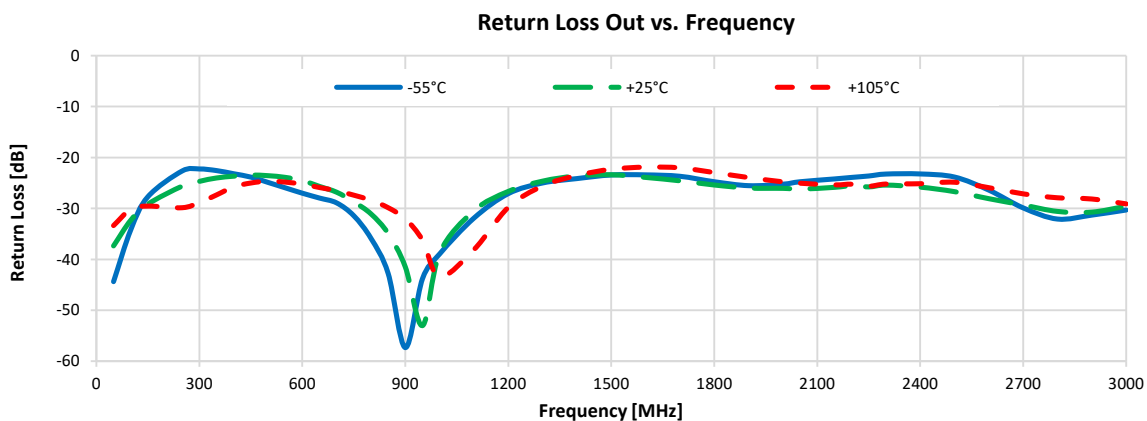
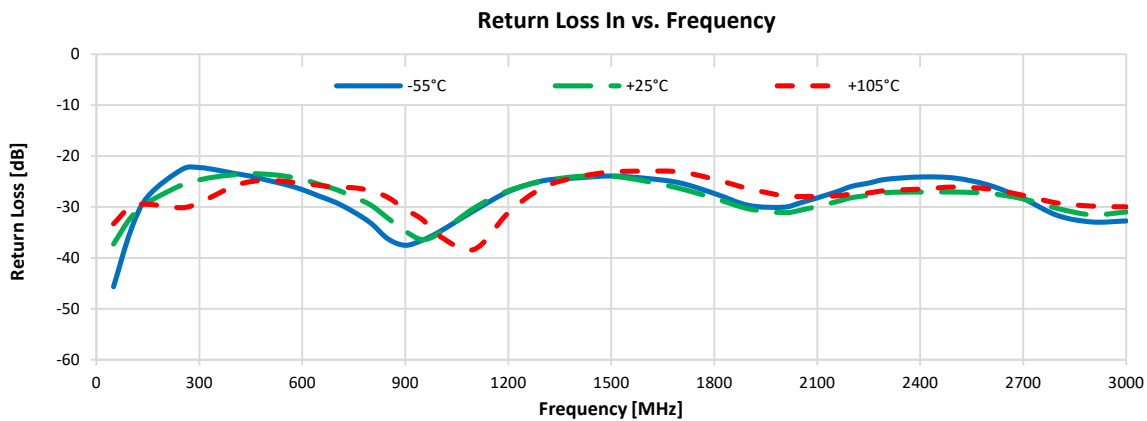
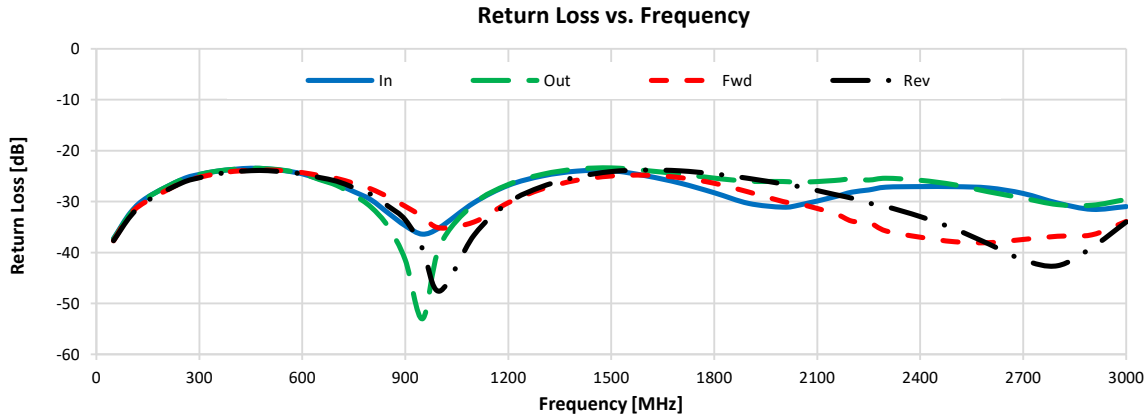

NOTES:

- A. Performance and quality attributes and conditions not expressly stated in this specification document are intended to be excluded and do not form a part of this specification document.
- B. Electrical specifications and performance data contained in this specification document are based on Mini-Circuit's applicable established test performance criteria and measurement instructions.
- C. The parts covered by this specification document are subject to Mini-Circuits standard limited warranty and terms and conditions (collectively, "Standard Terms"); Purchasers of this part are entitled to the rights and benefits contained therein. For a full statement of the Standard Terms and the exclusive rights and remedies thereunder, please visit Mini-Circuits' website at <https://www.minicircuits.com/terms/viewterm.html>



Typical Performance Graphs

Test Conditions: Input Power = +5 dbm, Configuration A.

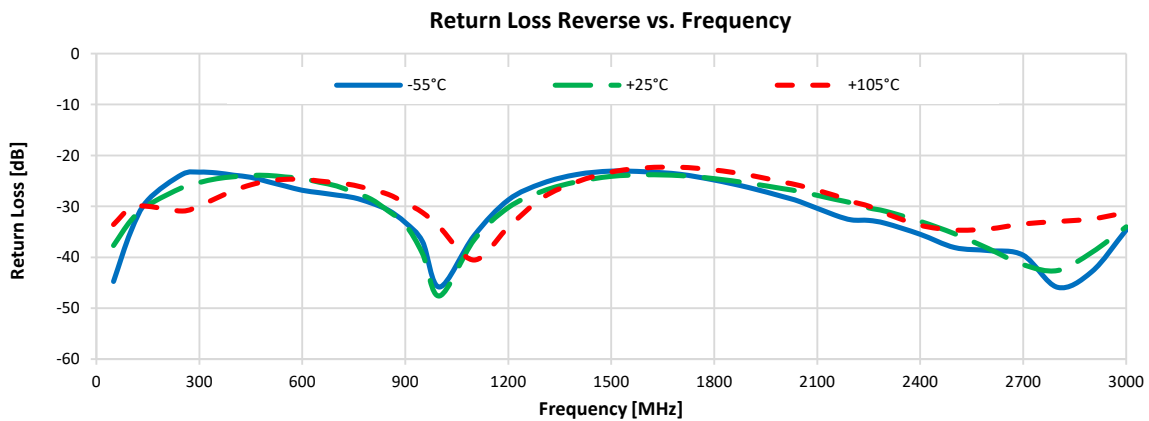
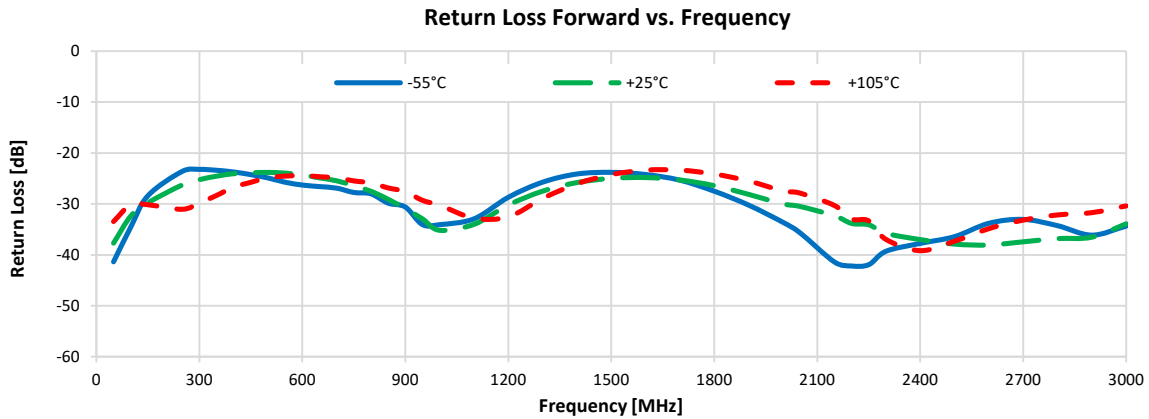

NOTES:

- A. Performance and quality attributes and conditions not expressly stated in this specification document are intended to be excluded and do not form a part of this specification document.
- B. Electrical specifications and performance data contained in this specification document are based on Mini-Circuit's applicable established test performance criteria and measurement instructions.
- C. The parts covered by this specification document are subject to Mini-Circuits standard limited warranty and terms and conditions (collectively, "Standard Terms"); Purchasers of this part are entitled to the rights and benefits contained therein. For a full statement of the Standard Terms and the exclusive rights and remedies thereunder, please visit Mini-Circuits' website at <https://www.minicircuits.com/terms/viewterm.html>



Case Style

PQ

Outline Dimensions

PQ2098

TOP SIDE

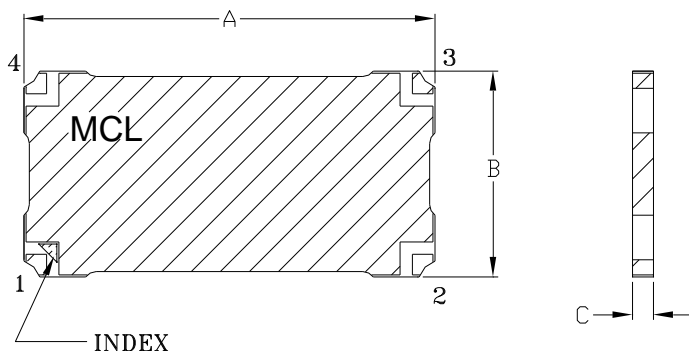

PCB LAND PATTERN

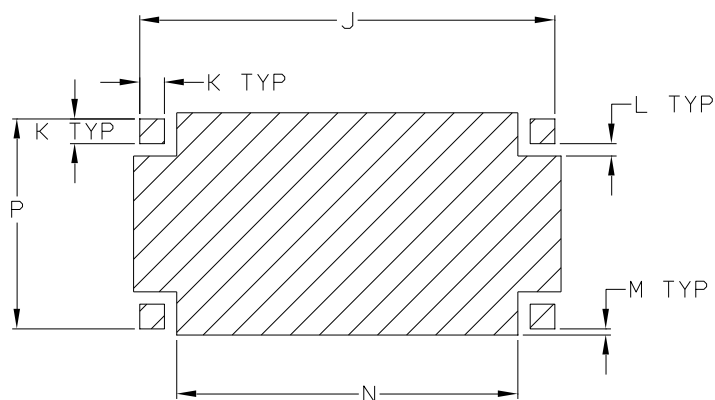

BOTTOM SIDE

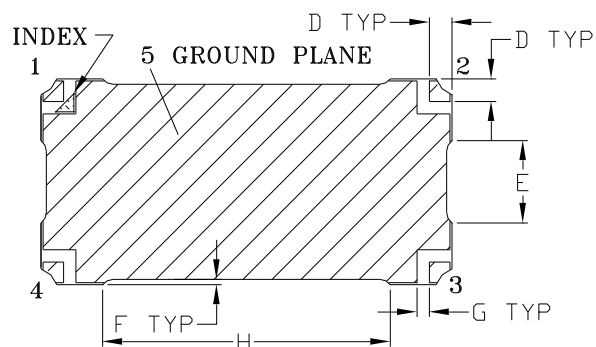

 METALLIZATION
  SOLDER RESIST

CASE#	A	B	C	D	E	F	G	H	J	K	L	M	N	P	WT. GRAMS
PQ2098	1.000 (25.40)	.500 (12.70)	.051 (1.30)	.055 (1.40)	.200 (5.08)	.013 (0.33)	.030 (0.76)	.700 (17.78)	1.010 (25.65)	.060 (1.52)	.030 (0.76)	.015 (0.38)	.830 (21.08)	.510 (12.95)	2.0

Dimensions are in inches (mm). Tolerances: 2PL. +/- .03; 3PL. +/- .010

Notes:

1. Base material: Printed wiring laminate.
2. Termination finish:
 For RoHS Cases, all models (+) suffix: 2-5 μ inch (.05-.13 microns) Immersion Gold.
 For RoHS-5 Cases, all models no (+) suffix: Tin-Lead plate.

 **Mini-Circuits**[®]

INTERNET <http://www.minicircuits.com>

P.O. Box 350166, Brooklyn, New York 11235-0003 (718) 934-4500 Fax (718) 332-4661

Distribution Centers NORTH AMERICA 800-654-7949 • 417-335-5935 • Fax 417-335-5945 • EUROPE 44-1252-832600 • Fax 44-1252-837010

Mini-Circuits ISO 9001 & ISO 14001 Certified

Tape & Reel Packaging TR-F118

DEVICE ORIENTATION IN T&R

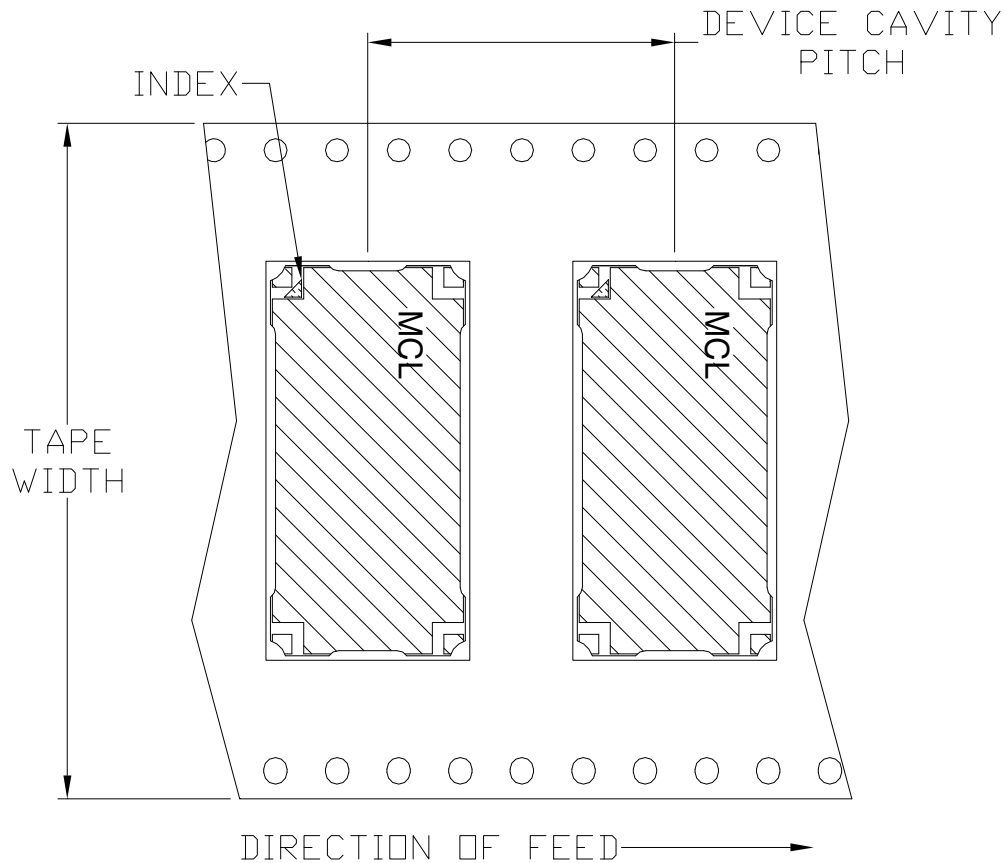

Tape Width, mm	Device Cavity Pitch, mm	Reel Size, inches	Devices per Reel
44	20	13	500

Mini-Circuits carrier tape materials provide protection from ESD (Electro-Static Discharge) during handling and transportation. Tapes are static dissipative and comply with industry standards EIA-481/EIA-541.

Go to: www.minicircuits.com/pages/pdfs/tape.pdf



INTERNET <http://www.minicircuits.com>

P.O. Box 350166, Brooklyn, New York 11235-0003 (718) 934-4500 Fax (718) 332-4661

Distribution Centers NORTH AMERICA 800-654-7949 • 417-335-5935 • Fax 417-335-5945 • EUROPE 44-1252-832600 • Fax 44-1252-837010

Mini-Circuits ISO 9001 & ISO 14001 Certified

THIRD ANGLE PROJECTION

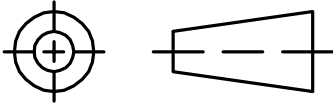

REVISIONS

REV	ECN No.	DESCRIPTION	DATE	DR	AUTH
OR	M165053	NEW RELEASE	12/17	DK	HH
OR	R92774	NEW RELEASE	12/17	DK	HH

SUGGESTED MOUNTING CONFIGURATION

FOR PQ2098 /2098-1/2098-2 CASE STYLES 04DC01 PIN CONNECTION, 50 OHM

TRACE TUNING
4 PL.
(SEE BELOW)

PACKAGE
OUTLINE

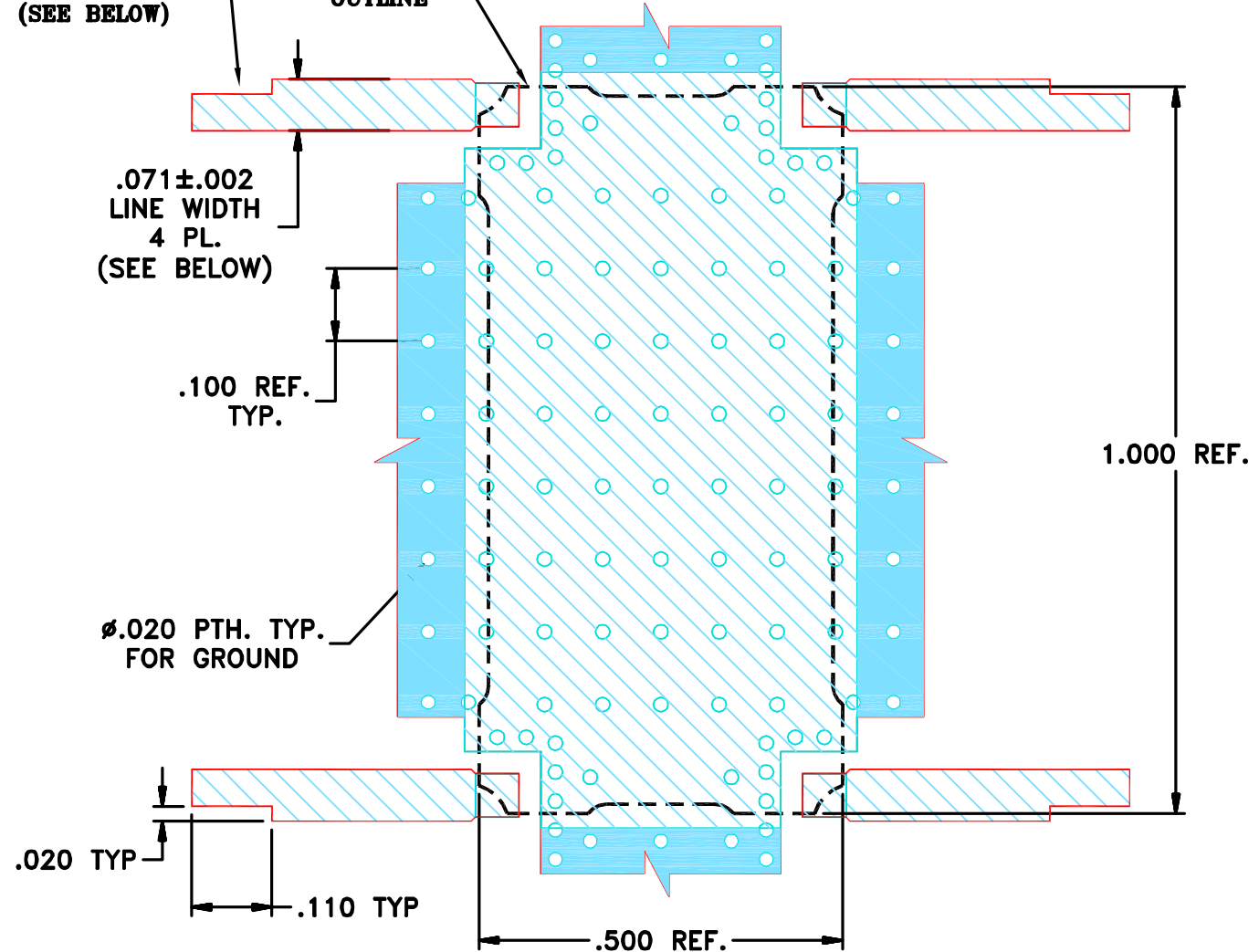

NOTES:

- TRACE WIDTH IS SHOWN FOR ROGERS R04003C WITH DIELECTRIC THICKNESS. 0.032"±.0015". COPPER: 1 OZ. EACH SIDE. FOR OTHER MATERIALS TRACE WIDTH MAY NEED TO BE MODIFIED.
- BOTTOM SIDE OF THE PCB IS CONTINUOUS GROUND PLANE.
- TRACE TUNING IN RF LINES MAY BE NEEDED TO ACHIEVE SPECIFIED PERFORMANCE.

DENOTES PCB COPPER LAYOUT WITH SMOBC (SOLDER MASK OVER BARE COPPER)

DENOTES COPPER LAND PATTERN FREE OF SOLDERMASK

UNLESS OTHERWISE SPECIFIED

INITIALS

DATE

DIMENSIONS ARE IN INCHES

DRAWN	DK (RAYON)	03 DEC 17
-------	------------	-----------

TOLERANCES ON:

CHECKED	RM (RAYON)	03 DEC 17
---------	------------	-----------

2 PL DECIMALS ±

APPROVED	HH (RAYON)	03 DEC 17
----------	------------	-----------

3 PL DECIMALS ± .005

ANGLES ± 1°

FRACTIONS ±



Mini-Circuits®

13 Neptune Avenue
Brooklyn NY 11235

PL FOR MBD PQ2098
TB-863-1 (50Ω)

Mini-Circuits®
THIS DOCUMENT AND ITS CONTENTS ARE THE PROPERTY OF MINI-CIRCUITS. EXCEPT FOR USE EXPRESSLY GRANTED, IN WRITING, TO ITS VENDORS, VENDEE AND THE UNITED STATES GOVERNMENT, MINI-CIRCUITS RESERVES ALL PROPRIETARY DESIGN, USE, MANUFACTURING AND REPRODUCTION RIGHTS THERE TO. THESE CONTENTS SHALL NOT BE USED, DUPLICATED OR DISCLOSED TO ANY OUTSIDE PARTY, IN WHOLE OR IN PART, WITHOUT WRITTEN PERMISSION OF MINI-CIRCUITS.

SIZE A	CODE IDENT 15542	DRAWING NO: 98-PL-538	REV: OR
-----------	---------------------	--------------------------	------------

ASHEETA1.DWG REV:A DATE:01/12/95

FILE:98PL538(OR) SCALE: 4:1 SHEET: 1 OF 1

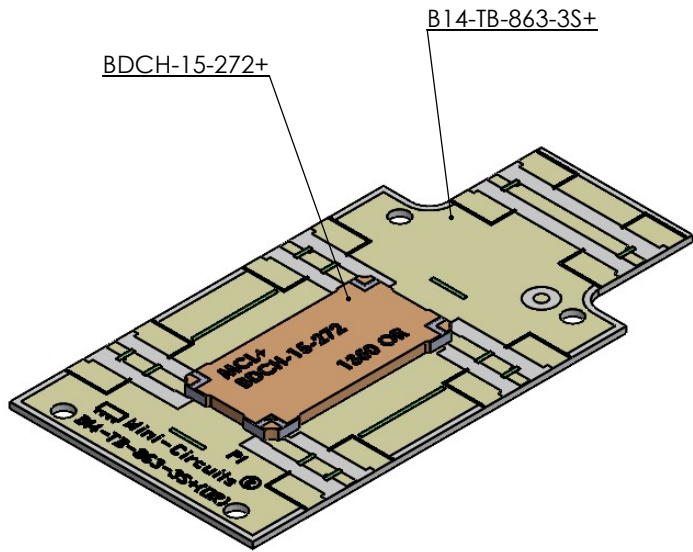

DISPENCE SOLDER PASTE
4 PLACES

MCP-104362

DISPENCE SOLDER PASTE
3 PLACES

MCP-104362

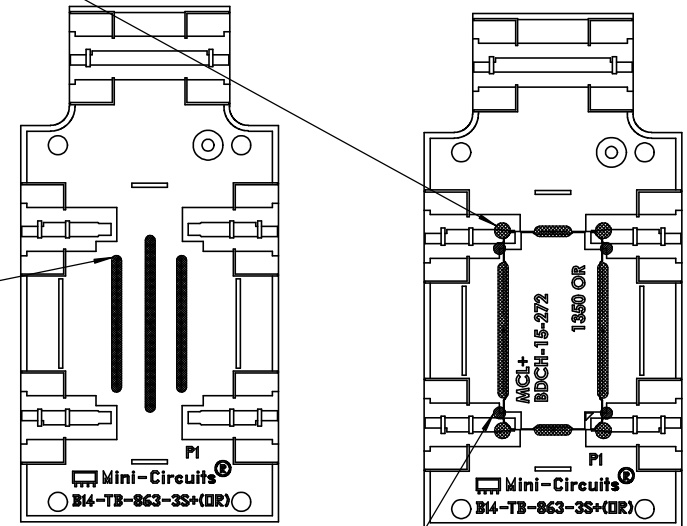

DISPENCE RTV
4 PLACES

MCP-7987

ASSEMBLY NOTES:

1. DISPENCE SOLDER PASTE ON PCB ACCORDING TO DRAWING.
2. REFLOW LdFr-245-UUH-ZXC PROGRAM WITH SMALL JIG FIXTURE.

ITEM NO.	PART NUMBER	DESCRIPTION	QTY.
1	BDCH-15-272+	BI DIR COUP / SURF MT / RoHS	1
2	B14-TB-863-3S+	PCB RO4003C 2.6X1.3X.032 GS266	1
3	B20-14-F34+	CONN SMA-F END LAUNCH A .089"	6
4	B18-JB-001+	WASHER SPLIT LOCK #2 ROHS	8
5	B18-HB-002+	WASHER FL#2 OD.187/ID.096 RoHS	8
6	B85-TS-537+	SPACER 2.60 X1.30 X.20 BRASS	1
7	B18-DB-038+	SCREW PAN HD #2-56 3/8"LG ROHS	8
8	B13-3902-1+	HTSK, BLK ANDZ 3.00X2.60X1.00	1
9	B16-10-53+	SIL THRM LBL .60X 1.10 RoHS	1

UNLESS OTHERWISE SPECIFIED		INITIALS	DATE	MODEL:									
DIMENSIONS ARE IN INCHES (MM)		DRAWN	13 Jan 2025	TB-BDCH-15-272+									
TOLERANCES ON:		CHECKED	13 Jan 2025										
2 PL DECIMALS ± .01	63	APPROVED	13 Jan 2025	ASSEMBLY DRAWING EVALUATION BOARD FOR TB-BDCH-15-272+									
3 PL DECIMALS ± .005													
ANGLES ± 1°					<table border="1"> <tr> <td>SIZE</td> <td>CODE IDENT</td> <td>DRAWING NO.</td> <td>REV.</td> </tr> <tr> <td>B</td> <td>15542</td> <td>IL-0433-20</td> <td>A0</td> </tr> </table>	SIZE	CODE IDENT	DRAWING NO.	REV.	B	15542	IL-0433-20	A0
SIZE	CODE IDENT	DRAWING NO.	REV.										
B	15542	IL-0433-20	A0										
FRACTIONS ± 1/32"		<p>THIS DOCUMENT AND ITS CONTENTS ARE THE PROPERTY OF MINI-CIRCUITS ISRAEL LTD. EXCEPT FOR USE EXPRESSLY GRANTED, IN WRITING, TO ITS VENDORS, VENDEE AND THE ISRAELI GOVERNMENT. MINI-CIRCUITS ISRAEL LTD RESERVES ALL PROPRIETARY DESIGN, USE, MANUFACTURING AND REPRODUCTION RIGHTS THERETO. THESE CONTENTS SHALL NOT BE USED, DUPLICATED OR DISCLOSED TO ANY OUTSIDE PARTY, IN WHOLE OR IN PART, WITHOUT WRITTEN PERMISSION OF MINI-CIRCUITS ISRAEL LTD.</p>			<table border="1"> <tr> <td>FILE:</td> <td>SCALE:</td> <td>SHEET:</td> </tr> <tr> <td>TB-BDCH-15-272 +(A0)</td> <td>1:1</td> <td>1 OF 4</td> </tr> </table>	FILE:	SCALE:	SHEET:	TB-BDCH-15-272 +(A0)	1:1	1 OF 4		
FILE:	SCALE:	SHEET:											
TB-BDCH-15-272 +(A0)	1:1	1 OF 4											

THIRD ANGLE PROJECTION

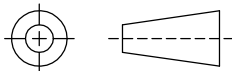

REV	ECO No.	DESCRIPTION	DATE	DR	AUTH
A0	ECO-024069	NEW RELEASE	13 JAN 2025	AL	PG
REVISIONS					

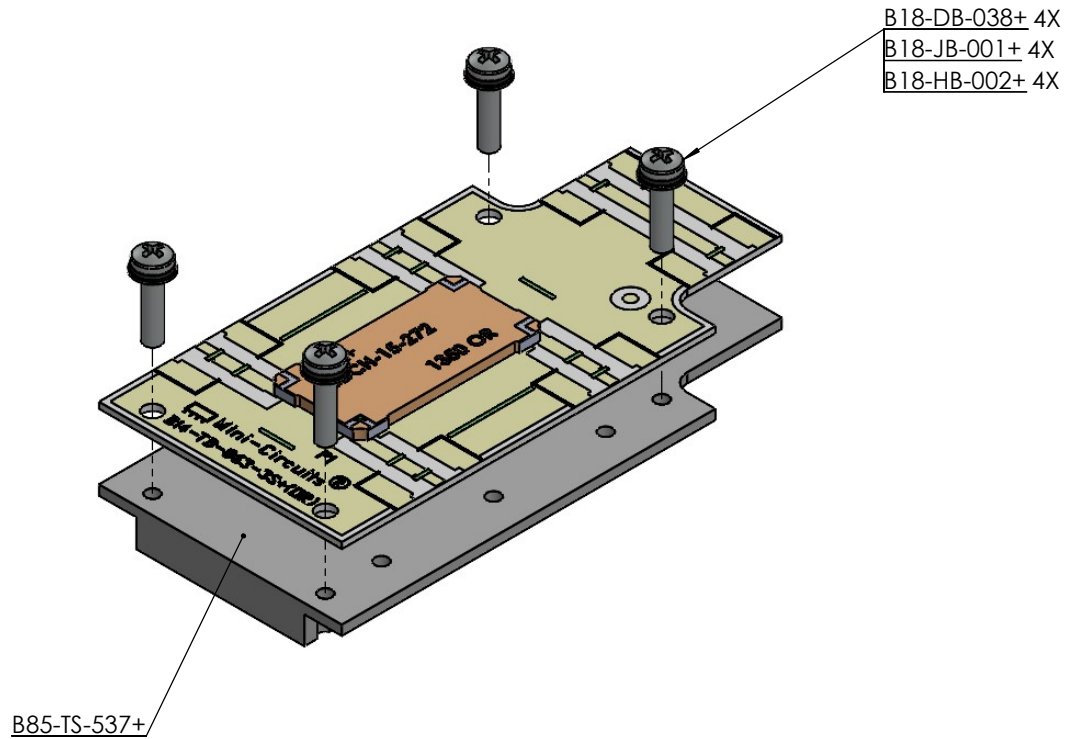

TOP VIEW SOLDER PASTE LOCATION ON PCB

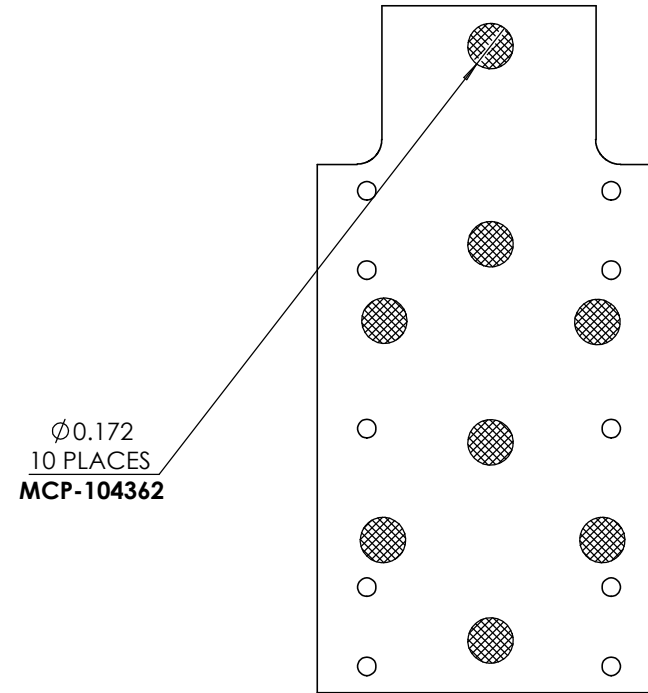

ASSEMBLY NOTES:

1. DISPENCE SOLDER DOTS AS SHOWN.
2. PUT PCB ON CARRIER.
3. IN ORER TO PREVENT MISALIGNMENT OF THE PCB USE SCREWS TO SECURE THE PCB.

Mini-Circuits Israel		ALL DIMENSIONS ARE IN INCHES EXCEPT OTHERWISE SPECIFIED		
THIS DOCUMENT AND ITS CONTENTS ARE THE PROPERTY OF MINI-CIRCUITS ISRAEL LTD. EXCEPT FOR USE EXPRESSLY GRANTED, IN WRITING, TO ITS VENDORS, VENDEE AND THE ISRAELI GOVERNMENT. MINI-CIRCUITS ISRAEL LTD RESERVES ALL PROPRIETARY DESIGN, USE, MANUFACTURING AND REPRODUCTION RIGHTS THERETO. THESE CONTENTS SHALL NOT BE USED, DUPLICATED OR DISCLOSED TO ANY OUTSIDE PARTY, IN WHOLE OR IN PART, WITHOUT WRITTEN PERMISSION OF MINI-CIRCUITS ISRAEL LTD.				
SIZE B	CODE IDENT 15542	DRAWING NO: IL-0433-20	REV: A0	
FILE: TB-BDCH-15-272 +(A0)		SCALE: 2:1	SHEET: 2 OF 4	

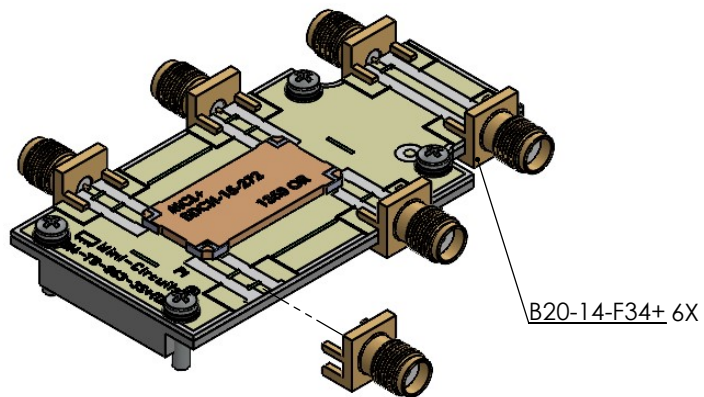

MANUALLY SOLDER PINS
TO PCB 6 PLACES
MCP-5063

CONNECTOR

DETAIL A
SCALE 4:1

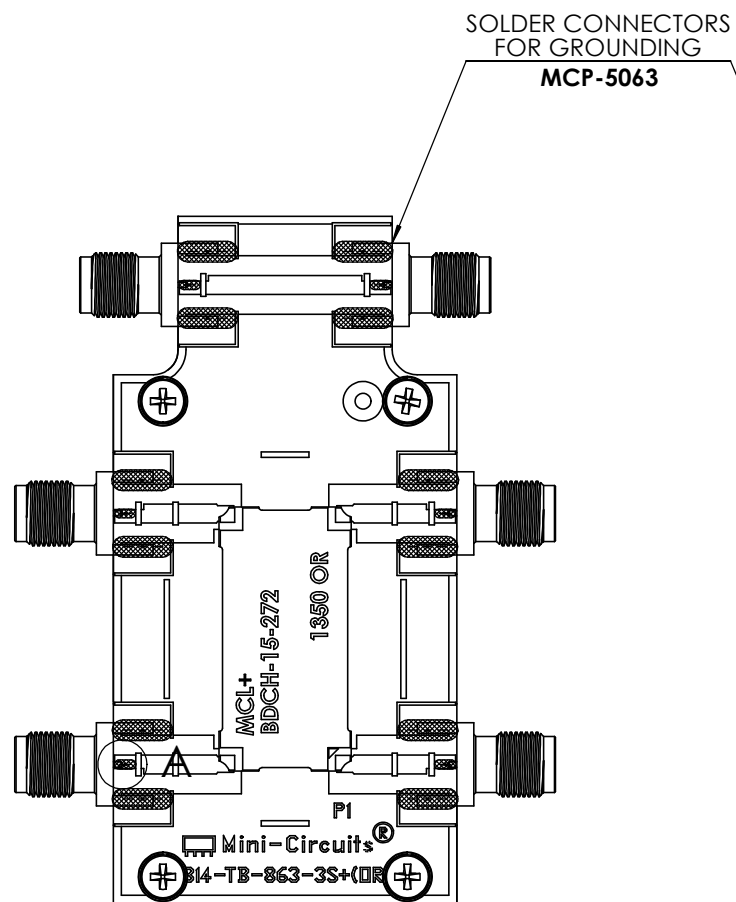
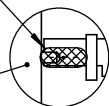

BOTTOM VIEW

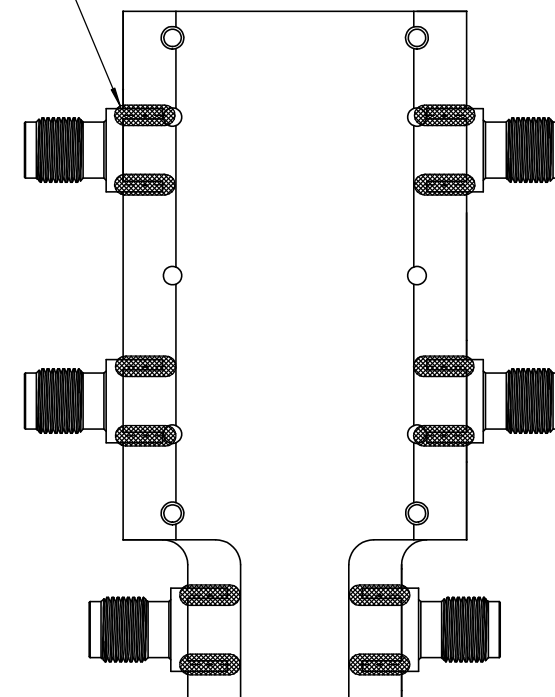

- ASSEMBLY NOTES:**
TO PREVENT GAP BETWEEN CONNECTOR FORK AND PCB,
FOLLOW THESE ASSEMBLY STEPS:
1. SOLDER CONNECTOR FORK ON TOP SIDE OF PCB.
 2. SOLDER CONNECTOR FORK ON BOTTOM SIDE OF ASSEMBLY.
 3. SOLDER CONNECTOR CENTER PIN ON TOP SIDE OF PCB.

Mini-Circuits Israel		ALL DIMENSIONS ARE IN INCHES EXCEPT OTHERWISE SPECIFIED		
THIS DOCUMENT AND ITS CONTENTS ARE THE PROPERTY OF MINI-CIRCUITS ISRAEL LTD. EXCEPT FOR USE EXPRESSLY GRANTED, IN WRITING, TO ITS VENDORS, VEEDEE AND THE ISRAELI GOVERNMENT. MINI-CIRCUITS ISRAEL LTD RESERVES ALL PROPRIETARY DESIGN, USE, MANUFACTURING AND REPRODUCTION RIGHTS THERETO. THESE CONTENTS SHALL NOT BE USED, DUPLICATED OR DISCLOSED TO ANY OUTSIDE PARTY, IN WHOLE OR IN PART, WITHOUT WRITTEN PERMISSION OF MINI-CIRCUITS ISRAEL LTD.				
SIZE B	CODE IDENT 15542	DRAWING NO: IL-0433-20	REV: A0	
FILE: TB-BDCH-15-272 +(A0)	SCALE: 1:1	SHEET: 3 OF 4		

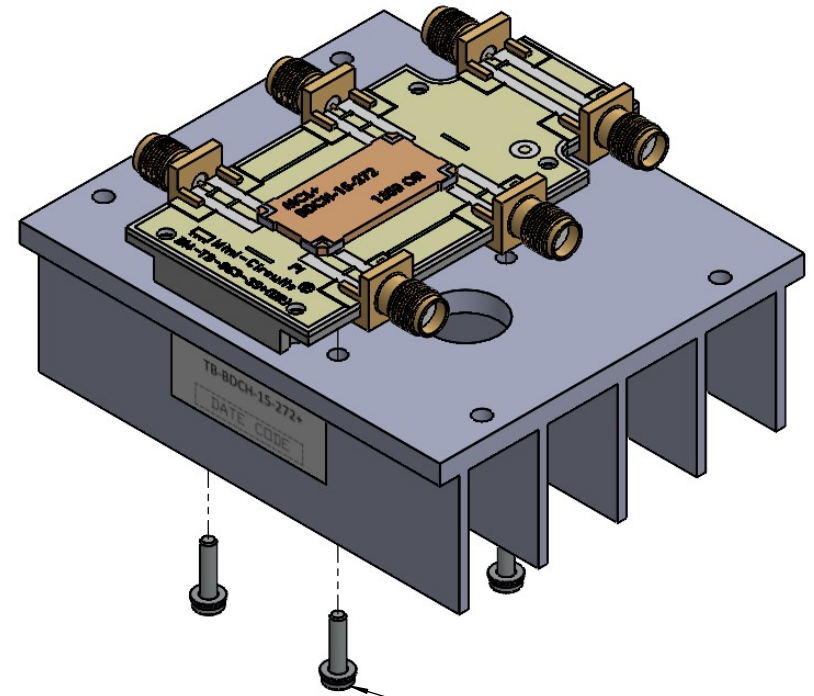
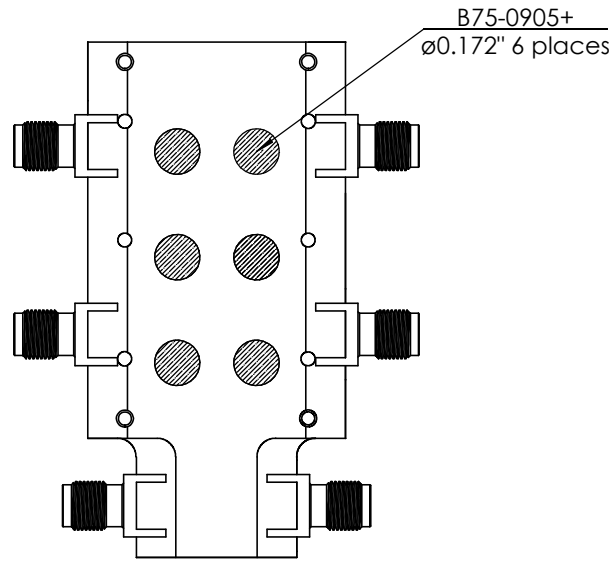

B18-DB-038+ 4X
 B18-JB-001+ 4X
 B18-HB-002+ 4X

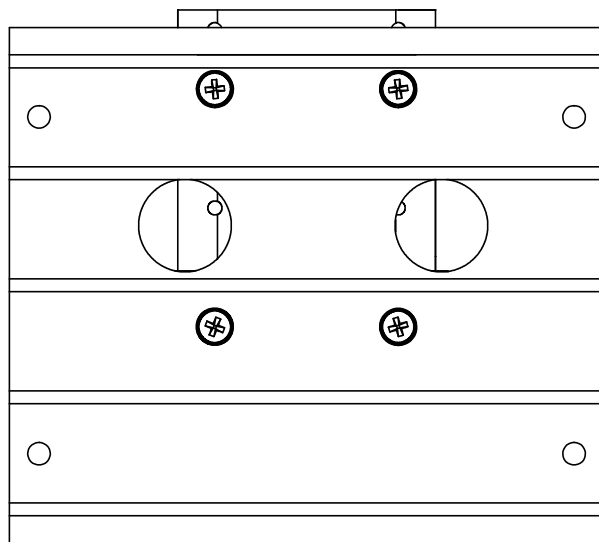

B16-10-53+

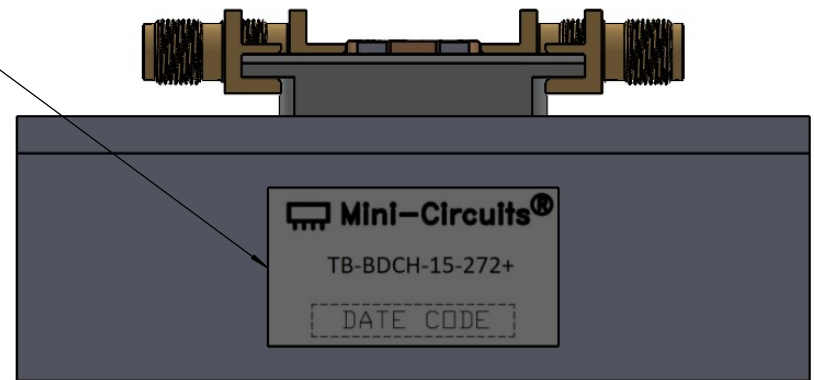

		ALL DIMENSIONS ARE IN INCHES EXCEPT OTHERWISE SPECIFIED			
<small>THIS DOCUMENT AND ITS CONTENTS ARE THE PROPERTY OF MINI-CIRCUITS ISRAEL LTD. EXCEPT FOR USE EXPRESSLY GRANTED, IN WRITING, TO ITS VENDORS, VEEDEE AND THE ISRAELI GOVERNMENT. MINI-CIRCUITS ISRAEL LTD RESERVES ALL PROPRIETARY DESIGN, USE, MANUFACTURING AND REPRODUCTION RIGHTS THERETO. THESE CONTENTS SHALL NOT BE USED, DUPLICATED OR DISCLOSED TO ANY OUTSIDE PARTY, IN WHOLE OR IN PART, WITHOUT WRITTEN PERMISSION OF MINI-CIRCUITS ISRAEL LTD.</small>		SIZE B	CODE IDENT 15542	DRAWING NO: IL-0433-20	REV: A0
FILE: TB-BDCH-15-272 +(A0)		SCALE: 2:1	SHEET: 4 OF 4		



All Mini-Circuits products are manufactured under exacting quality assurance and control standards, and are capable of meeting published specifications after being subjected to any or all of the following physical and environmental test.

Specification	Test/Inspection Condition	Reference/Spec
Operating Temperature	-55° to 105° C Case Environment	Individual Model Data Sheet
Storage Temperature	-55° to 105°C Ambient Environment	Individual Model Data Sheet
Humidity	90 to 95% RH, 240 hours, 50°C	MIL-STD-202, Method 103, Condition A, Except 50°C and end-point electrical test done within 12 hours
Thermal Shock	-55° to 100°C, 100 cycles	MIL-STD-202, Method 107, Condition A-3, except +100°C
Solder Reflow Heat	Sn-Pb Eutectic Process 225°C peak Pb-Free Process 245° - 250°C peak	J-STD-020C, Table 4-1, 4-2 and 5-2, Figure 5-1
Solderability	10X Magnification	J-STD-002, Para 4.2.5, Test S, 95% Coverage
Vibration (high Frequency)	20g peak, 10-2000 Hz, 12 times in each of three perpendicular directions (total 36)	MIL-STD-883, Method 2007.3, Condition A
Mechanical Shock	50g, 11 ms, 1/2-sine, 18 shocks: 3 each direction, each of 3 axes	MIL-STD-202, Method 213, Condition A
Marking Resistance to Solvents	Isopropyl alcohol + mineral spirits at 25°C; terpene defluxer at 25°C; distilled water + proylene glycol monomethyl ether + monoethanolamine at 63°C to 70°C	MIL-STD-202, Method 215