



STRIPLINE SURFACE MOUNT

Bi-Directional Coupler

BDCH-10-63+

50Ω 2000 to 6000 MHz 10 dB 180W

KEY FEATURES

- High power handling, up to 180W
- Ultra wideband, 2000 to 6000 MHz
- Low insertion loss, 0.10 dB

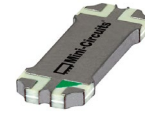

Generic photo used for illustration purposes only

APPLICATIONS

- Transmission signal monitoring
- Antenna reflection monitoring
- Distributed antenna systems (DAS)
- Wireless transmitters

FUNCTIONAL DIAGRAM

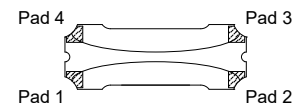

PRODUCT OVERVIEW

Mini-Circuits' BDCH-10-63+ is a high-power bi-directional coupler providing high power handling up to 180W and mainline loss of 0.1 dB. High directivity of 22 dB provides accurate sampling from the coupled port, and 25 dB return loss provides excellent matching over full frequency range. Covering frequencies from 2000 to 6000 MHz, the model supports a wide variety of applications from power amplifiers and antenna feeds to various digital communications and more. The coupler is designed into an open printed laminate (0.56" x 0.20" x 0.08") with wrap-around terminations for good solderability and easy visual inspection.

ELECTRICAL SPECIFICATIONS^{1,2} AT +25°C

Parameter	Frequency (MHz)	Min.	Typ.	Max.	Units
Frequency Range		2000		6000	MHz
Mainline Loss ³	2000 - 6000	-	0.10	0.25	dB
Coupling Nominal	2000 - 6000	-	10±1.0	-	dB
Coupling Flatness (±)	2000 - 6000	-	±1.50	-	dB
Directivity	2000 - 6000	18	22	-	dB
Return Loss (Input/Output)	2000 - 6000	18	25	-	dB
Return Loss (Coupled Forward/Reverse)	2000 - 6000	18	25	-	dB
Thermal Resistance ⁴	2000 - 6000	-	0.25	-	°C/W

1. Tested on Evaluation Board TB-864+. De-embedded to the device reference plane.

2. Model is symmetrical and all ports are interchangeable, see Port Function Description/Configuration table for details and S-Parameters for actual performance.

3. Does not include theoretical loss due to coupling. Nominal theoretical loss is 0.46 dB.

4. Thermal Resistance is defined as, example (θ_{jc})= (Hot Spot Temperature on DUT - Base Plate Temperature)/Input Power)

ABSOLUTE MAXIMUM RATINGS⁵

Operating Case Temperature ⁶	-55 °C to +105 °C	
Storage Temperature	-55 °C to +105 °C	
Power Input	+85 °C case	180 W
	+95 °C case	130 W
	+105 °C case	100 W
DC Current	2 A	

5. Permanent damage may occur if any of these limits are exceeded.

6. Case temperature is defined as temperature on base plate.





TYPICAL PERFORMANCE GRAPHS

* Data corresponds to Configuration A at +25°C unless specified otherwise.

BDCH-10-63+

Insertion Loss vs. Frequency

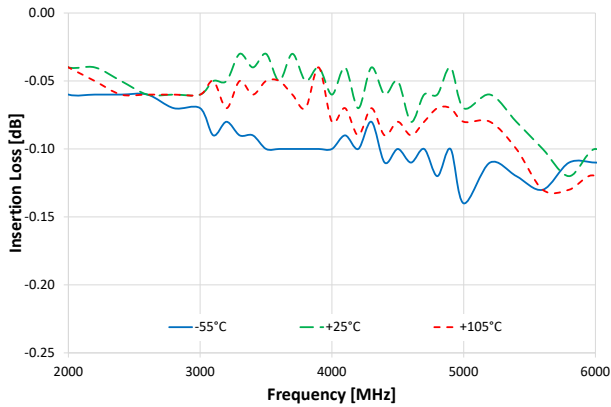

BDCH-10-63+

Coupling Loss vs. Frequency

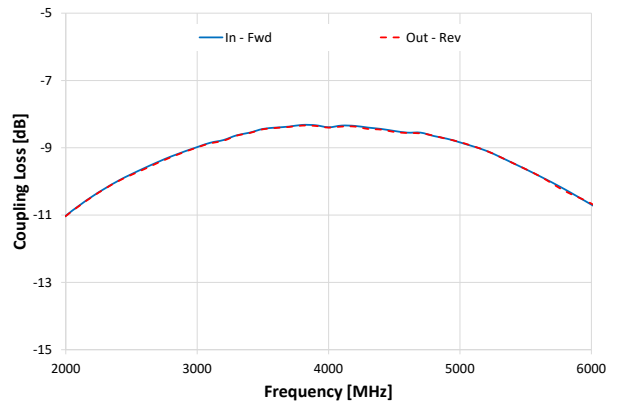

BDCH-10-63+

Directivity vs. Frequency

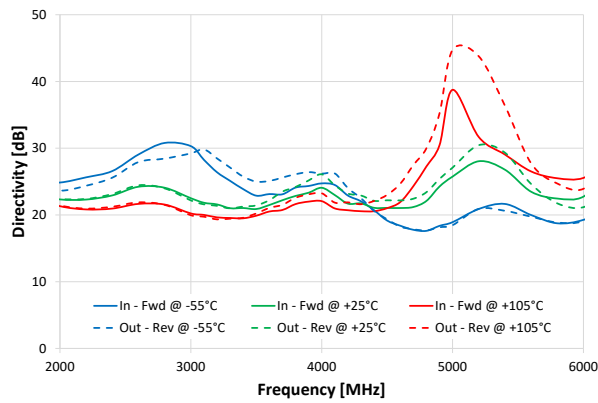

BDCH-10-63+

Return Loss vs. Frequency

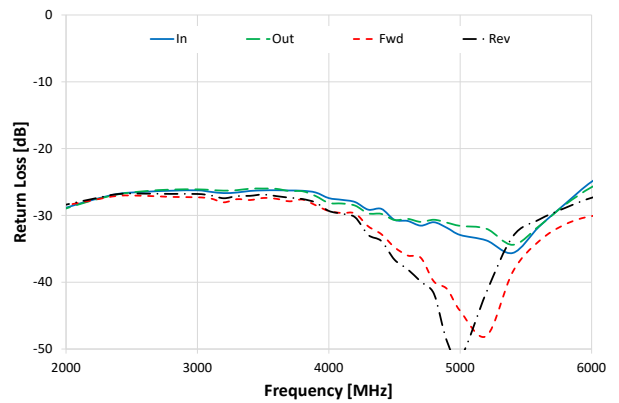



FUNCTIONAL DIAGRAM

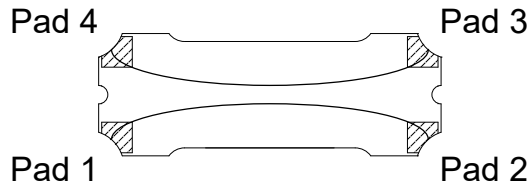

Figure 1. BDCH-10-63+ Functional Diagram

PAD DESCRIPTION/CONFIGURATION⁷

Function	Pad Number	Description
Input	1	Connects to RF Input Port
Output	2	Connects to RF Output Port
Coupled Forward	4	Connects to Coupled Forward Port
Coupled Reverse	3	Connects to Coupled Reverse Port
Ground	5	Connects to Ground

Configuration	Input	Output	Coupled Forward	Coupled Reverse
A	1	2	4	3
B	2	1	3	4
C	3	4	2	1
D	4	3	1	2

⁷ Model is symmetrical and all ports are interchangeable, see Port Function Description/Configuration table for details and S-Parameters for actual performance.

SUGGESTED PCB LAYOUT (PL-470)

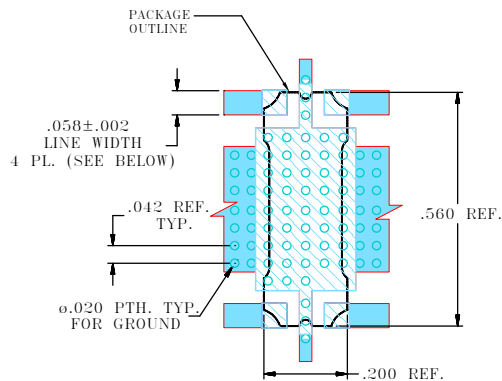

- NOTES:
- TRACE WIDTH IS SHOWN FOR ROGERS R05880 WITH DIELECTRIC THICKNESS, 0.020"±.0015". COPPER: 1 OZ. EACH SIDE. FOR OTHER MATERIALS TRACE WIDTH MAY NEED TO BE MODIFIED.
 - BOTTOM SIDE OF THE PCB IS CONTINUOUS GROUND PLANE.
- DENOTES PCB COPPER LAYOUT WITH SMOBC (SOLDER MASK OVER BARE COPPER)
 DENOTES COPPER LAND PATTERN FREE OF SOLDERMASK

Figure 2. Suggested PCB Layout PL-470

CASE STYLE DRAWING (PQ2099-1)

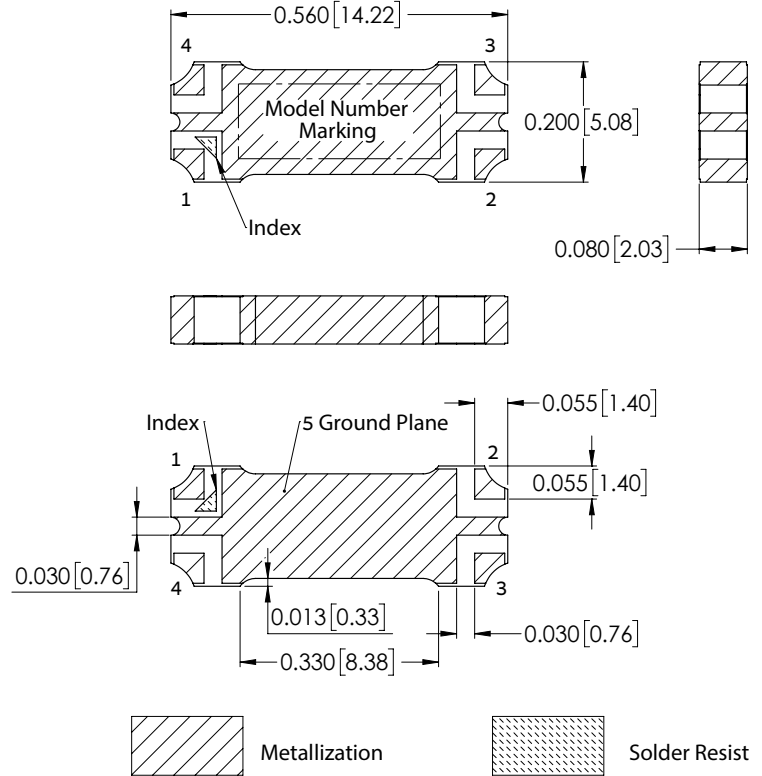

NOTES:

- Base material: Printed wiring laminate.
- Termination finish: 2-5 μinch (.05-.13 microns) Immersion Gold.
- Weight: 1.5 grams
- Marking may contain other features or characters for internal lot control.

PRODUCT MARKING*: BDCH-10-63+

*Marking may contain other features or characters for internal lot control.



STRIPLINE SURFACE MOUNT

Bi-Directional Coupler

BDCH-10-63+

50Ω 2000 to 6000 MHz 10 dB 180W

ADDITIONAL DETAILED INFORMATION IS AVAILABLE ON OUR DASH BOARD.

[CLICK HERE](#)

Performance Data & Graphs	Data Graphs S-Parameter (S4P Files) Data Set (.zip file) De-embedded to device pads
Case Style	PQ2099-1 Lead Finish: 2-5 inch (0.05-0.13 microns) Immersion Gold.
RoHS Status	Compliant
Tape and Reel	F48
Suggested Layout for PCB Design	PL-470
Evaluation Board	TB-864+
	Gerber File
Environmental Rating	ENV02T8

NOTES

- A. Performance and quality attributes and conditions not expressly stated in this specification document are intended to be excluded and do not form a part of this specification document.
- B. Electrical specifications and performance data contained in this specification document are based on Mini-Circuits' applicable established test performance criteria and measurement instructions.
- C. The parts covered by this specification document are subject to Mini-Circuits' standard limited warranty and terms and conditions (collectively, "Standard Terms"); Purchasers of this part are entitled to the rights and benefits contained therein. For a full statement of the standard terms and the exclusive rights and remedies thereunder, please visit Mini-Circuits' website at www.minicircuits.com/terms/viewterm.html



Bi-Directional Coupler

BDCH-10-63+

Typical Performance Data

Test Conditions: Input Power = +5 dbm, Temperature = -55°C, Configuration A.

Freq. (MHz)	I. Loss (dB) In - Out	Coupling (dB)		Directivity (dB) In - Fwd	Return Loss (dB)			
		In - Fwd	Out - Rev		In	Out	Fwd	Rev
1000	-0.03	-16.04	-16.04	21.31	-35.88	-35.46	-31.84	-31.92
1200	-0.03	-14.62	-14.61	22.49	-34.33	-33.95	-32.01	-31.91
1400	-0.03	-13.45	-13.45	24.15	-32.14	-32.08	-31.42	-31.25
1600	-0.04	-12.49	-12.49	24.95	-31.46	-31.68	-29.59	-29.57
1800	-0.05	-11.68	-11.68	24.92	-28.92	-30.51	-29.59	-29.73
2000	-0.06	-10.99	-10.98	24.86	-27.66	-29.50	-29.05	-28.97
2200	-0.06	-10.41	-10.40	25.64	-27.73	-29.18	-28.43	-29.21
2400	-0.06	-9.93	-9.93	26.58	-27.65	-28.34	-27.51	-27.92
2600	-0.06	-9.54	-9.54	29.06	-28.10	-28.03	-27.52	-27.56
2800	-0.07	-9.21	-9.21	30.79	-29.46	-27.94	-30.19	-29.10
3000	-0.07	-8.92	-8.92	30.31	-33.19	-29.01	-34.24	-32.12
3100	-0.09	-8.78	-8.77	28.26	-35.65	-29.85	-36.27	-34.21
3200	-0.08	-8.67	-8.67	26.40	-37.70	-30.16	-37.18	-35.07
3300	-0.09	-8.57	-8.57	25.11	-39.37	-31.83	-36.28	-36.32
3400	-0.09	-8.48	-8.48	23.87	-37.05	-31.27	-36.13	-36.06
3500	-0.10	-8.38	-8.38	22.89	-34.59	-31.02	-36.13	-36.60
3600	-0.10	-8.34	-8.34	23.13	-32.68	-30.77	-37.74	-37.47
3700	-0.10	-8.28	-8.27	23.10	-31.39	-30.58	-38.03	-37.92
3800	-0.10	-8.26	-8.27	24.10	-31.88	-31.66	-39.10	-39.94
3900	-0.10	-8.24	-8.23	24.34	-32.41	-33.75	-41.39	-40.17
4000	-0.10	-8.25	-8.26	24.73	-33.29	-36.47	-40.71	-38.51
4100	-0.09	-8.30	-8.30	24.49	-35.32	-39.59	-38.79	-37.25
4200	-0.10	-8.29	-8.29	22.91	-36.87	-42.10	-38.21	-38.64
4300	-0.08	-8.31	-8.32	22.05	-39.49	-43.19	-34.37	-35.73
4400	-0.11	-8.35	-8.35	20.71	-37.96	-40.77	-33.84	-33.76
4500	-0.10	-8.35	-8.35	19.16	-39.12	-43.19	-34.91	-34.43
4600	-0.11	-8.43	-8.41	18.39	-38.95	-43.18	-40.57	-38.28
4700	-0.10	-8.44	-8.42	17.78	-36.41	-36.54	-40.77	-42.37
4800	-0.12	-8.51	-8.48	17.62	-32.54	-32.80	-47.51	-41.72
4900	-0.10	-8.60	-8.57	18.37	-32.97	-32.76	-46.78	-40.63
5000	-0.14	-8.70	-8.65	18.92	-31.51	-31.01	-62.79	-40.93
5200	-0.11	-9.02	-8.95	20.90	-28.34	-27.68	-39.06	-44.72
5400	-0.12	-9.30	-9.28	21.65	-27.23	-27.69	-42.45	-39.42
5600	-0.13	-9.69	-9.70	19.99	-26.99	-28.09	-37.14	-36.84
5800	-0.11	-10.14	-10.15	18.75	-24.97	-25.72	-34.84	-31.67
6000	-0.11	-10.64	-10.60	19.27	-23.67	-23.91	-28.04	-29.41
6200	-0.11	-11.07	-11.08	21.12	-23.03	-21.76	-27.34	-26.65
6400	-0.08	-11.64	-11.69	24.88	-21.65	-20.76	-27.06	-25.22
6600	-0.09	-12.42	-12.44	22.01	-20.39	-19.63	-26.93	-24.87
6800	-0.07	-13.36	-13.56	18.47	-18.90	-17.72	-25.81	-23.22
7000	-0.01	-14.39	-14.55	16.06	-17.23	-16.16	-23.71	-20.90

Bi-Directional Coupler

BDCH-10-63+

Typical Performance Data

Test Conditions: Input Power = +5 dbm, Temperature = -55°C, Configuration B.

Freq. (MHz)	I. Loss (dB) In - Out	Coupling (dB)		Directivity (dB) In - Fwd	Return Loss (dB)			
		In - Fwd	Out - Rev		In	Out	Fwd	Rev
1000	-0.03	-16.04	-16.04	21.71	-35.46	-35.88	-31.92	-31.84
1200	-0.03	-14.61	-14.62	22.98	-33.95	-34.33	-31.91	-32.01
1400	-0.04	-13.45	-13.45	24.38	-32.08	-32.14	-31.25	-31.42
1600	-0.05	-12.49	-12.49	25.63	-31.68	-31.46	-29.57	-29.59
1800	-0.06	-11.68	-11.68	24.79	-30.51	-28.92	-29.73	-29.59
2000	-0.06	-10.98	-10.99	23.66	-29.50	-27.66	-28.97	-29.05
2200	-0.06	-10.40	-10.41	24.38	-29.18	-27.73	-29.21	-28.43
2400	-0.06	-9.93	-9.93	25.59	-28.34	-27.65	-27.92	-27.51
2600	-0.06	-9.54	-9.54	27.93	-28.03	-28.10	-27.56	-27.52
2800	-0.07	-9.21	-9.21	28.44	-27.94	-29.46	-29.10	-30.19
3000	-0.08	-8.92	-8.92	29.23	-29.01	-33.19	-32.12	-34.24
3100	-0.10	-8.77	-8.78	29.82	-29.85	-35.65	-34.21	-36.27
3200	-0.09	-8.67	-8.67	28.47	-30.16	-37.70	-35.07	-37.18
3300	-0.10	-8.57	-8.57	27.10	-31.83	-39.37	-36.32	-36.28
3400	-0.09	-8.48	-8.48	25.74	-31.27	-37.05	-36.06	-36.13
3500	-0.10	-8.38	-8.38	25.00	-31.02	-34.59	-36.60	-36.13
3600	-0.10	-8.34	-8.34	25.09	-30.77	-32.68	-37.47	-37.74
3700	-0.10	-8.27	-8.28	25.61	-30.58	-31.39	-37.92	-38.03
3800	-0.10	-8.27	-8.26	26.10	-31.66	-31.88	-39.94	-39.10
3900	-0.10	-8.23	-8.24	26.42	-33.75	-32.41	-40.17	-41.39
4000	-0.10	-8.26	-8.25	26.19	-36.47	-33.29	-38.51	-40.71
4100	-0.09	-8.30	-8.30	26.22	-39.59	-35.32	-37.25	-38.79
4200	-0.09	-8.29	-8.29	24.03	-42.10	-36.87	-38.64	-38.21
4300	-0.08	-8.32	-8.31	22.51	-43.19	-39.49	-35.73	-34.37
4400	-0.10	-8.35	-8.35	20.60	-40.77	-37.96	-33.76	-33.84
4500	-0.10	-8.35	-8.35	19.35	-43.19	-39.12	-34.43	-34.91
4600	-0.11	-8.41	-8.43	18.25	-43.18	-38.95	-38.28	-40.57
4700	-0.10	-8.42	-8.44	17.86	-36.54	-36.41	-42.37	-40.77
4800	-0.12	-8.48	-8.51	17.68	-32.80	-32.54	-41.72	-47.51
4900	-0.11	-8.57	-8.60	18.16	-32.76	-32.97	-40.63	-46.78
5000	-0.14	-8.65	-8.70	18.47	-31.01	-31.51	-40.93	-62.79
5200	-0.12	-8.95	-9.02	20.91	-27.68	-28.34	-44.72	-39.06
5400	-0.13	-9.28	-9.30	20.62	-27.69	-27.23	-39.42	-42.45
5600	-0.12	-9.70	-9.69	19.74	-28.09	-26.99	-36.84	-37.14
5800	-0.09	-10.15	-10.14	18.87	-25.72	-24.97	-31.67	-34.84
6000	-0.10	-10.60	-10.64	19.12	-23.91	-23.67	-29.41	-28.04
6200	-0.10	-11.08	-11.07	22.09	-21.76	-23.03	-26.65	-27.34
6400	-0.06	-11.69	-11.64	24.04	-20.76	-21.65	-25.22	-27.06
6600	-0.07	-12.44	-12.42	22.93	-19.63	-20.39	-24.87	-26.93
6800	-0.04	-13.56	-13.36	19.50	-17.72	-18.90	-23.22	-25.81
7000	0.00	-14.55	-14.39	15.69	-16.16	-17.23	-20.90	-23.71

Bi-Directional Coupler

BDCH-10-63+

Typical Performance Data

Test Conditions: Input Power = +5 dbm, Temperature = -55°C, Configuration C.

Freq. (MHz)	I. Loss (dB) In - Out	Coupling (dB)		Directivity (dB) In - Fwd	Return Loss (dB)			
		In - Fwd	Out - Rev		In	Out	Fwd	Rev
1000	-0.02	-16.04	-16.05	21.45	-31.92	-31.84	-35.46	-35.88
1200	-0.02	-14.62	-14.63	22.66	-31.91	-32.01	-33.95	-34.33
1400	-0.03	-13.46	-13.46	24.33	-31.25	-31.42	-32.08	-32.14
1600	-0.03	-12.50	-12.50	25.34	-29.57	-29.59	-31.68	-31.46
1800	-0.04	-11.68	-11.68	25.18	-29.73	-29.59	-30.51	-28.92
2000	-0.05	-10.98	-11.00	24.71	-28.97	-29.05	-29.50	-27.66
2200	-0.05	-10.41	-10.42	25.18	-29.21	-28.43	-29.18	-27.73
2400	-0.04	-9.93	-9.95	25.98	-27.92	-27.51	-28.34	-27.65
2600	-0.05	-9.54	-9.55	28.34	-27.56	-27.52	-28.03	-28.10
2800	-0.05	-9.22	-9.22	30.55	-29.10	-30.19	-27.94	-29.46
3000	-0.07	-8.93	-8.93	30.12	-32.12	-34.24	-29.01	-33.19
3100	-0.08	-8.78	-8.78	27.91	-34.21	-36.27	-29.85	-35.65
3200	-0.06	-8.68	-8.67	25.88	-35.07	-37.18	-30.16	-37.70
3300	-0.08	-8.58	-8.58	24.35	-36.32	-36.28	-31.83	-39.37
3400	-0.08	-8.49	-8.48	23.07	-36.06	-36.13	-31.27	-37.05
3500	-0.09	-8.40	-8.39	21.95	-36.60	-36.13	-31.02	-34.59
3600	-0.09	-8.34	-8.34	22.04	-37.47	-37.74	-30.77	-32.68
3700	-0.09	-8.29	-8.28	21.87	-37.92	-38.03	-30.58	-31.39
3800	-0.08	-8.27	-8.27	22.73	-39.94	-39.10	-31.66	-31.88
3900	-0.10	-8.25	-8.25	23.05	-40.17	-41.39	-33.75	-32.41
4000	-0.07	-8.27	-8.27	23.55	-38.51	-40.71	-36.47	-33.29
4100	-0.08	-8.32	-8.31	24.10	-37.25	-38.79	-39.59	-35.32
4200	-0.06	-8.30	-8.30	22.94	-38.64	-38.21	-42.10	-36.87
4300	-0.08	-8.33	-8.33	22.48	-35.73	-34.37	-43.19	-39.49
4400	-0.08	-8.35	-8.34	20.97	-33.76	-33.84	-40.77	-37.96
4500	-0.09	-8.35	-8.36	19.49	-34.43	-34.91	-43.19	-39.12
4600	-0.09	-8.41	-8.42	18.39	-38.28	-40.57	-43.18	-38.95
4700	-0.09	-8.43	-8.45	17.86	-42.37	-40.77	-36.54	-36.41
4800	-0.10	-8.47	-8.49	17.52	-41.72	-47.51	-32.80	-32.54
4900	-0.09	-8.58	-8.59	18.20	-40.63	-46.78	-32.76	-32.97
5000	-0.10	-8.65	-8.68	18.65	-40.93	-62.79	-31.01	-31.51
5200	-0.10	-8.96	-9.01	20.82	-44.72	-39.06	-27.68	-28.34
5400	-0.11	-9.29	-9.30	23.26	-39.42	-42.45	-27.69	-27.23
5600	-0.10	-9.69	-9.69	22.23	-36.84	-37.14	-28.09	-26.99
5800	-0.06	-10.13	-10.13	20.08	-31.67	-34.84	-25.72	-24.97
6000	-0.09	-10.57	-10.64	20.07	-29.41	-28.04	-23.91	-23.67
6200	-0.09	-11.06	-11.08	21.04	-26.65	-27.34	-21.76	-23.03
6400	-0.07	-11.71	-11.66	23.93	-25.22	-27.06	-20.76	-21.65
6600	-0.08	-12.48	-12.46	23.69	-24.87	-26.93	-19.63	-20.39
6800	-0.08	-13.59	-13.39	19.43	-23.22	-25.81	-17.72	-18.90
7000	-0.05	-14.51	-14.41	15.51	-20.90	-23.71	-16.16	-17.23

Bi-Directional Coupler

BDCH-10-63+

Typical Performance Data

Test Conditions: Input Power = +5 dbm, Temperature = -55°C, Configuration D.

Freq. (MHz)	I. Loss (dB) In - Out	Coupling (dB)		Directivity (dB) In - Fwd	Return Loss (dB)			
		In - Fwd	Out - Rev		In	Out	Fwd	Rev
1000	-0.02	-16.05	-16.04	21.72	-31.84	-31.92	-35.88	-35.46
1200	-0.02	-14.63	-14.62	22.88	-32.01	-31.91	-34.33	-33.95
1400	-0.02	-13.46	-13.46	24.14	-31.42	-31.25	-32.14	-32.08
1600	-0.03	-12.50	-12.50	25.60	-29.59	-29.57	-31.46	-31.68
1800	-0.04	-11.68	-11.68	25.09	-29.59	-29.73	-28.92	-30.51
2000	-0.04	-11.00	-10.98	23.87	-29.05	-28.97	-27.66	-29.50
2200	-0.04	-10.42	-10.41	24.33	-28.43	-29.21	-27.73	-29.18
2400	-0.04	-9.95	-9.93	25.13	-27.51	-27.92	-27.65	-28.34
2600	-0.05	-9.55	-9.54	27.32	-27.52	-27.56	-28.10	-28.03
2800	-0.05	-9.22	-9.22	28.68	-30.19	-29.10	-29.46	-27.94
3000	-0.06	-8.93	-8.93	30.14	-34.24	-32.12	-33.19	-29.01
3100	-0.08	-8.78	-8.78	30.63	-36.27	-34.21	-35.65	-29.85
3200	-0.06	-8.67	-8.68	29.02	-37.18	-35.07	-37.70	-30.16
3300	-0.08	-8.58	-8.58	27.55	-36.28	-36.32	-39.37	-31.83
3400	-0.07	-8.48	-8.49	26.12	-36.13	-36.06	-37.05	-31.27
3500	-0.08	-8.39	-8.40	24.97	-36.13	-36.60	-34.59	-31.02
3600	-0.08	-8.34	-8.34	24.94	-37.74	-37.47	-32.68	-30.77
3700	-0.09	-8.28	-8.29	25.09	-38.03	-37.92	-31.39	-30.58
3800	-0.08	-8.27	-8.27	25.19	-39.10	-39.94	-31.88	-31.66
3900	-0.09	-8.25	-8.25	25.20	-41.39	-40.17	-32.41	-33.75
4000	-0.07	-8.27	-8.27	24.83	-40.71	-38.51	-33.29	-36.47
4100	-0.08	-8.31	-8.32	25.12	-38.79	-37.25	-35.32	-39.59
4200	-0.07	-8.30	-8.30	23.52	-38.21	-38.64	-36.87	-42.10
4300	-0.09	-8.33	-8.33	22.67	-34.37	-35.73	-39.49	-43.19
4400	-0.09	-8.34	-8.35	21.10	-33.84	-33.76	-37.96	-40.77
4500	-0.10	-8.36	-8.35	20.00	-34.91	-34.43	-39.12	-43.19
4600	-0.10	-8.42	-8.41	18.98	-40.57	-38.28	-38.95	-43.18
4700	-0.10	-8.45	-8.43	18.35	-40.77	-42.37	-36.41	-36.54
4800	-0.11	-8.49	-8.47	18.07	-47.51	-41.72	-32.54	-32.80
4900	-0.10	-8.59	-8.58	18.40	-46.78	-40.63	-32.97	-32.76
5000	-0.11	-8.68	-8.65	18.40	-62.79	-40.93	-31.51	-31.01
5200	-0.11	-9.01	-8.96	20.34	-39.06	-44.72	-28.34	-27.68
5400	-0.13	-9.30	-9.29	20.69	-42.45	-39.42	-27.23	-27.69
5600	-0.12	-9.69	-9.69	20.92	-37.14	-36.84	-26.99	-28.09
5800	-0.09	-10.13	-10.13	20.08	-34.84	-31.67	-24.97	-25.72
6000	-0.11	-10.64	-10.57	19.55	-28.04	-29.41	-23.67	-23.91
6200	-0.12	-11.08	-11.06	21.56	-27.34	-26.65	-23.03	-21.76
6400	-0.10	-11.66	-11.71	22.66	-27.06	-25.22	-21.65	-20.76
6600	-0.11	-12.46	-12.48	22.61	-26.93	-24.87	-20.39	-19.63
6800	-0.12	-13.39	-13.59	20.59	-25.81	-23.22	-18.90	-17.72
7000	-0.08	-14.41	-14.51	16.33	-23.71	-20.90	-17.23	-16.16

Bi-Directional Coupler

BDCH-10-63+

Typical Performance Data

Test Conditions: Input Power = +5 dbm, Temperature = +25°C, Configuration A.

Freq. (MHz)	I. Loss (dB) In - Out	Coupling (dB)		Directivity (dB) In - Fwd	Return Loss (dB)			
		In - Fwd	Out - Rev		In	Out	Fwd	Rev
1000	-0.03	-16.05	-16.06	21.20	-42.69	-43.50	-37.18	-37.34
1200	-0.03	-14.63	-14.64	21.72	-37.26	-37.79	-34.04	-34.31
1400	-0.04	-13.48	-13.49	22.98	-34.00	-34.59	-31.78	-32.07
1600	-0.04	-12.52	-12.53	23.57	-31.75	-32.22	-30.39	-30.52
1800	-0.03	-11.71	-11.71	23.09	-30.13	-30.45	-29.34	-29.36
2000	-0.04	-11.02	-11.03	22.33	-28.85	-28.96	-28.50	-28.39
2200	-0.04	-10.45	-10.46	22.31	-27.69	-27.77	-27.73	-27.54
2400	-0.05	-9.98	-9.99	22.93	-26.76	-26.83	-27.06	-26.79
2600	-0.06	-9.60	-9.63	24.23	-26.47	-26.37	-27.07	-26.74
2800	-0.06	-9.26	-9.28	24.08	-26.30	-26.13	-27.23	-26.78
3000	-0.06	-8.98	-8.99	22.51	-26.24	-26.10	-27.29	-26.79
3100	-0.05	-8.85	-8.87	21.83	-26.47	-26.19	-27.46	-27.00
3200	-0.05	-8.77	-8.79	21.58	-26.66	-26.29	-28.04	-27.43
3300	-0.03	-8.63	-8.64	21.01	-26.57	-26.22	-27.57	-27.11
3400	-0.04	-8.55	-8.56	21.04	-26.34	-26.00	-27.70	-27.07
3500	-0.03	-8.44	-8.45	20.89	-26.25	-25.98	-27.39	-26.87
3600	-0.05	-8.40	-8.41	21.49	-26.23	-26.02	-27.51	-27.11
3700	-0.03	-8.37	-8.38	22.21	-26.27	-26.35	-27.89	-27.35
3800	-0.05	-8.32	-8.34	22.85	-26.31	-26.38	-27.63	-27.55
3900	-0.04	-8.33	-8.35	23.33	-26.57	-27.10	-28.48	-28.08
4000	-0.06	-8.39	-8.40	24.07	-27.41	-28.13	-29.35	-29.33
4100	-0.04	-8.34	-8.37	22.98	-27.67	-28.22	-29.64	-29.75
4200	-0.07	-8.35	-8.37	21.70	-28.00	-28.53	-29.71	-30.28
4300	-0.04	-8.40	-8.44	21.73	-29.14	-29.69	-31.64	-32.92
4400	-0.06	-8.44	-8.46	21.07	-29.02	-29.77	-32.81	-33.84
4500	-0.05	-8.50	-8.53	21.06	-30.66	-30.69	-34.76	-36.63
4600	-0.08	-8.55	-8.56	21.04	-30.83	-30.52	-36.00	-38.06
4700	-0.06	-8.55	-8.57	21.19	-31.53	-30.97	-36.34	-39.92
4800	-0.06	-8.65	-8.64	22.10	-31.02	-30.65	-39.90	-41.72
4900	-0.04	-8.73	-8.74	24.26	-31.87	-31.09	-41.02	-48.88
5000	-0.07	-8.84	-8.83	25.75	-32.93	-31.57	-44.30	-51.37
5200	-0.06	-9.09	-9.09	28.05	-33.75	-32.00	-48.04	-41.48
5400	-0.08	-9.45	-9.45	26.78	-35.62	-34.40	-38.44	-33.16
5600	-0.10	-9.83	-9.83	23.48	-31.69	-31.60	-33.85	-30.63
5800	-0.12	-10.24	-10.29	22.46	-28.25	-28.38	-31.33	-28.87
6000	-0.10	-10.69	-10.66	22.75	-24.96	-25.77	-30.10	-27.36
6200	-0.12	-11.14	-11.18	26.69	-22.84	-24.03	-30.00	-26.58
6400	-0.14	-11.71	-11.85	24.56	-20.92	-22.24	-29.92	-26.80
6600	-0.16	-12.53	-12.60	19.94	-19.34	-20.73	-30.46	-24.62
6800	-0.17	-13.55	-13.55	16.63	-17.85	-18.65	-26.68	-23.59
7000	-0.20	-14.41	-14.54	14.70	-16.55	-16.83	-24.27	-21.76

Bi-Directional Coupler

BDCH-10-63+

Typical Performance Data

Test Conditions: Input Power = +5 dbm, Temperature = +25°C, Configuration B.

Freq. (MHz)	I. Loss (dB) In - Out	Coupling (dB)		Directivity (dB) In - Fwd	Return Loss (dB)			
		In - Fwd	Out - Rev		In	Out	Fwd	Rev
1000	-0.02	-16.06	-16.05	21.25	-43.50	-42.69	-37.34	-37.18
1200	-0.03	-14.64	-14.63	21.89	-37.79	-37.26	-34.31	-34.04
1400	-0.03	-13.49	-13.48	23.14	-34.59	-34.00	-32.07	-31.78
1600	-0.03	-12.53	-12.52	23.91	-32.22	-31.75	-30.52	-30.39
1800	-0.03	-11.71	-11.71	23.28	-30.45	-30.13	-29.36	-29.34
2000	-0.04	-11.03	-11.02	22.43	-28.96	-28.85	-28.39	-28.50
2200	-0.05	-10.46	-10.45	22.41	-27.77	-27.69	-27.54	-27.73
2400	-0.06	-9.99	-9.98	23.14	-26.83	-26.76	-26.79	-27.06
2600	-0.06	-9.63	-9.60	24.45	-26.37	-26.47	-26.74	-27.07
2800	-0.06	-9.28	-9.26	23.98	-26.13	-26.30	-26.78	-27.23
3000	-0.06	-8.99	-8.98	22.18	-26.10	-26.24	-26.79	-27.29
3100	-0.05	-8.87	-8.85	21.59	-26.19	-26.47	-27.00	-27.46
3200	-0.05	-8.79	-8.77	21.37	-26.29	-26.66	-27.43	-28.04
3300	-0.04	-8.64	-8.63	20.99	-26.22	-26.57	-27.11	-27.57
3400	-0.04	-8.56	-8.55	21.26	-26.00	-26.34	-27.07	-27.70
3500	-0.04	-8.45	-8.44	21.43	-25.98	-26.25	-26.87	-27.39
3600	-0.05	-8.41	-8.40	22.22	-26.02	-26.23	-27.11	-27.51
3700	-0.05	-8.38	-8.37	23.50	-26.35	-26.27	-27.35	-27.89
3800	-0.05	-8.34	-8.32	24.19	-26.38	-26.31	-27.55	-27.63
3900	-0.05	-8.35	-8.33	25.17	-27.10	-26.57	-28.08	-28.48
4000	-0.06	-8.40	-8.39	26.09	-28.13	-27.41	-29.33	-29.35
4100	-0.06	-8.37	-8.34	24.45	-28.22	-27.67	-29.75	-29.64
4200	-0.07	-8.37	-8.35	23.21	-28.53	-28.00	-30.28	-29.71
4300	-0.06	-8.44	-8.40	22.92	-29.69	-29.14	-32.92	-31.64
4400	-0.07	-8.46	-8.44	22.12	-29.77	-29.02	-33.84	-32.81
4500	-0.07	-8.53	-8.50	22.20	-30.69	-30.66	-36.63	-34.76
4600	-0.09	-8.56	-8.55	22.18	-30.52	-30.83	-38.06	-36.00
4700	-0.07	-8.57	-8.55	22.43	-30.97	-31.53	-39.92	-36.34
4800	-0.07	-8.64	-8.65	23.41	-30.65	-31.02	-41.72	-39.90
4900	-0.05	-8.74	-8.73	25.40	-31.09	-31.87	-48.88	-41.02
5000	-0.07	-8.83	-8.84	27.09	-31.57	-32.93	-51.37	-44.30
5200	-0.07	-9.09	-9.09	30.46	-32.00	-33.75	-41.48	-48.04
5400	-0.08	-9.45	-9.45	29.33	-34.40	-35.62	-33.16	-38.44
5600	-0.10	-9.83	-9.83	24.64	-31.60	-31.69	-30.63	-33.85
5800	-0.12	-10.29	-10.24	21.74	-28.38	-28.25	-28.87	-31.33
6000	-0.10	-10.66	-10.69	21.17	-25.77	-24.96	-27.36	-30.10
6200	-0.12	-11.18	-11.14	23.87	-24.03	-22.84	-26.58	-30.00
6400	-0.15	-11.85	-11.71	24.70	-22.24	-20.92	-26.80	-29.92
6600	-0.18	-12.60	-12.53	19.07	-20.73	-19.34	-24.62	-30.46
6800	-0.21	-13.55	-13.55	16.01	-18.65	-17.85	-23.59	-26.68
7000	-0.24	-14.54	-14.41	13.49	-16.83	-16.55	-21.76	-24.27

Bi-Directional Coupler

BDCH-10-63+

Typical Performance Data

Test Conditions: Input Power = +5 dbm, Temperature = +25°C, Configuration C.

Freq. (MHz)	I. Loss (dB) In - Out	Coupling (dB)		Directivity (dB) In - Fwd	Return Loss (dB)			
		In - Fwd	Out - Rev		In	Out	Fwd	Rev
1000	-0.02	-16.06	-16.06	21.26	-37.34	-37.18	-43.50	-42.69
1200	-0.02	-14.63	-14.64	21.87	-34.31	-34.04	-37.79	-37.26
1400	-0.02	-13.48	-13.48	23.20	-32.07	-31.78	-34.59	-34.00
1600	-0.03	-12.53	-12.53	23.91	-30.52	-30.39	-32.22	-31.75
1800	-0.02	-11.71	-11.71	23.27	-29.36	-29.34	-30.45	-30.13
2000	-0.03	-11.03	-11.03	22.27	-28.39	-28.50	-28.96	-28.85
2200	-0.03	-10.46	-10.46	22.18	-27.54	-27.73	-27.77	-27.69
2400	-0.04	-9.98	-9.99	22.88	-26.79	-27.06	-26.83	-26.76
2600	-0.05	-9.63	-9.61	24.10	-26.74	-27.07	-26.37	-26.47
2800	-0.04	-9.28	-9.27	23.87	-26.78	-27.23	-26.13	-26.30
3000	-0.05	-9.00	-8.98	22.13	-26.79	-27.29	-26.10	-26.24
3100	-0.04	-8.87	-8.86	21.34	-27.00	-27.46	-26.19	-26.47
3200	-0.04	-8.79	-8.77	21.01	-27.43	-28.04	-26.29	-26.66
3300	-0.02	-8.65	-8.64	20.46	-27.11	-27.57	-26.22	-26.57
3400	-0.03	-8.55	-8.55	20.56	-27.07	-27.70	-26.00	-26.34
3500	-0.02	-8.45	-8.45	20.38	-26.87	-27.39	-25.98	-26.25
3600	-0.03	-8.42	-8.40	21.01	-27.11	-27.51	-26.02	-26.23
3700	-0.02	-8.38	-8.38	21.74	-27.35	-27.89	-26.35	-26.27
3800	-0.04	-8.35	-8.33	22.48	-27.55	-27.63	-26.38	-26.31
3900	-0.02	-8.35	-8.35	23.08	-28.08	-28.48	-27.10	-26.57
4000	-0.05	-8.42	-8.40	23.89	-29.33	-29.35	-28.13	-27.41
4100	-0.03	-8.37	-8.37	22.96	-29.75	-29.64	-28.22	-27.67
4200	-0.05	-8.38	-8.36	21.62	-30.28	-29.71	-28.53	-28.00
4300	-0.03	-8.43	-8.43	21.66	-32.92	-31.64	-29.69	-29.14
4400	-0.05	-8.46	-8.44	20.84	-33.84	-32.81	-29.77	-29.02
4500	-0.03	-8.52	-8.51	20.90	-36.63	-34.76	-30.69	-30.66
4600	-0.05	-8.55	-8.54	20.80	-38.06	-36.00	-30.52	-30.83
4700	-0.05	-8.56	-8.55	21.11	-39.92	-36.34	-30.97	-31.53
4800	-0.05	-8.64	-8.64	22.07	-41.72	-39.90	-30.65	-31.02
4900	-0.03	-8.74	-8.72	24.28	-48.88	-41.02	-31.09	-31.87
5000	-0.05	-8.83	-8.83	25.64	-51.37	-44.30	-31.57	-32.93
5200	-0.05	-9.09	-9.09	28.43	-41.48	-48.04	-32.00	-33.75
5400	-0.06	-9.45	-9.46	28.10	-33.16	-38.44	-34.40	-35.62
5600	-0.06	-9.83	-9.83	24.30	-30.63	-33.85	-31.60	-31.69
5800	-0.07	-10.28	-10.24	23.00	-28.87	-31.33	-28.38	-28.25
6000	-0.06	-10.68	-10.70	23.62	-27.36	-30.10	-25.77	-24.96
6200	-0.07	-11.20	-11.17	27.19	-26.58	-30.00	-24.03	-22.84
6400	-0.08	-11.87	-11.73	24.90	-26.80	-29.92	-22.24	-20.92
6600	-0.09	-12.60	-12.56	20.68	-24.62	-30.46	-20.73	-19.34
6800	-0.10	-13.51	-13.59	16.42	-23.59	-26.68	-18.65	-17.85
7000	-0.11	-14.47	-14.47	14.15	-21.76	-24.27	-16.83	-16.55

Bi-Directional Coupler

BDCH-10-63+

Typical Performance Data

Test Conditions: Input Power = +5 dbm, Temperature = +25°C, Configuration D.

Freq. (MHz)	I. Loss (dB) In - Out	Coupling (dB)		Directivity (dB) In - Fwd	Return Loss (dB)			
		In - Fwd	Out - Rev		In	Out	Fwd	Rev
1000	-0.02	-16.06	-16.06	21.25	-37.18	-37.34	-42.69	-43.50
1200	-0.03	-14.64	-14.63	21.81	-34.04	-34.31	-37.26	-37.79
1400	-0.03	-13.48	-13.48	22.95	-31.78	-32.07	-34.00	-34.59
1600	-0.03	-12.53	-12.53	23.90	-30.39	-30.52	-31.75	-32.22
1800	-0.03	-11.71	-11.71	23.51	-29.34	-29.36	-30.13	-30.45
2000	-0.03	-11.03	-11.03	22.64	-28.50	-28.39	-28.85	-28.96
2200	-0.04	-10.46	-10.46	22.43	-27.73	-27.54	-27.69	-27.77
2400	-0.05	-9.99	-9.98	22.86	-27.06	-26.79	-26.76	-26.83
2600	-0.05	-9.61	-9.63	24.07	-27.07	-26.74	-26.47	-26.37
2800	-0.05	-9.27	-9.28	23.93	-27.23	-26.78	-26.30	-26.13
3000	-0.05	-8.98	-9.00	22.43	-27.29	-26.79	-26.24	-26.10
3100	-0.04	-8.86	-8.87	21.85	-27.46	-27.00	-26.47	-26.19
3200	-0.04	-8.77	-8.79	21.60	-28.04	-27.43	-26.66	-26.29
3300	-0.01	-8.64	-8.65	21.16	-27.57	-27.11	-26.57	-26.22
3400	-0.03	-8.55	-8.55	21.40	-27.70	-27.07	-26.34	-26.00
3500	-0.02	-8.45	-8.45	21.30	-27.39	-26.87	-26.25	-25.98
3600	-0.04	-8.40	-8.42	21.92	-27.51	-27.11	-26.23	-26.02
3700	-0.02	-8.38	-8.38	23.03	-27.89	-27.35	-26.27	-26.35
3800	-0.04	-8.33	-8.35	23.60	-27.63	-27.55	-26.31	-26.38
3900	-0.02	-8.35	-8.35	24.74	-28.48	-28.08	-26.57	-27.10
4000	-0.05	-8.40	-8.42	25.99	-29.35	-29.33	-27.41	-28.13
4100	-0.02	-8.37	-8.37	24.89	-29.64	-29.75	-27.67	-28.22
4200	-0.05	-8.36	-8.38	24.04	-29.71	-30.28	-28.00	-28.53
4300	-0.02	-8.43	-8.43	23.94	-31.64	-32.92	-29.14	-29.69
4400	-0.04	-8.44	-8.46	23.25	-32.81	-33.84	-29.02	-29.77
4500	-0.03	-8.51	-8.52	23.24	-34.76	-36.63	-30.66	-30.69
4600	-0.04	-8.54	-8.55	23.12	-36.00	-38.06	-30.83	-30.52
4700	-0.04	-8.55	-8.56	22.99	-36.34	-39.92	-31.53	-30.97
4800	-0.04	-8.64	-8.64	23.82	-39.90	-41.72	-31.02	-30.65
4900	-0.02	-8.72	-8.74	25.68	-41.02	-48.88	-31.87	-31.09
5000	-0.03	-8.83	-8.83	26.71	-44.30	-51.37	-32.93	-31.57
5200	-0.03	-9.09	-9.09	29.10	-48.04	-41.48	-33.75	-32.00
5400	-0.04	-9.46	-9.45	30.26	-38.44	-33.16	-35.62	-34.40
5600	-0.04	-9.83	-9.83	26.44	-33.85	-30.63	-31.69	-31.60
5800	-0.04	-10.24	-10.28	23.00	-31.33	-28.87	-28.25	-28.38
6000	-0.05	-10.70	-10.68	21.44	-30.10	-27.36	-24.96	-25.77
6200	-0.06	-11.17	-11.20	22.94	-30.00	-26.58	-22.84	-24.03
6400	-0.06	-11.73	-11.87	23.25	-29.92	-26.80	-20.92	-22.24
6600	-0.08	-12.56	-12.60	19.16	-30.46	-24.62	-19.34	-20.73
6800	-0.09	-13.59	-13.51	16.48	-26.68	-23.59	-17.85	-18.65
7000	-0.10	-14.47	-14.47	13.58	-24.27	-21.76	-16.55	-16.83

Bi-Directional Coupler

BDCH-10-63+

Typical Performance Data

Test Conditions: Input Power = +5 dbm, Temperature = +105°C, Configuration A.

Freq. (MHz)	I. Loss (dB) In - Out	Coupling (dB)		Directivity (dB) In - Fwd	Return Loss (dB)			
		In - Fwd	Out - Rev		In	Out	Fwd	Rev
1000	-0.03	-16.06	-16.06	21.73	-42.45	-43.01	-37.40	-37.23
1200	-0.04	-14.64	-14.64	22.38	-40.09	-40.56	-36.78	-36.61
1400	-0.04	-13.48	-13.49	23.47	-36.91	-38.17	-34.99	-35.18
1600	-0.04	-12.53	-12.54	23.73	-35.15	-36.11	-33.43	-33.65
1800	-0.03	-11.71	-11.72	22.67	-32.99	-33.52	-31.55	-31.55
2000	-0.04	-11.03	-11.04	21.32	-30.61	-30.72	-29.69	-29.55
2200	-0.05	-10.47	-10.49	20.83	-28.53	-28.56	-27.94	-27.60
2400	-0.06	-10.00	-10.01	20.96	-26.55	-26.49	-26.62	-26.25
2600	-0.06	-9.61	-9.62	21.66	-25.37	-25.29	-26.09	-25.63
2800	-0.06	-9.30	-9.31	21.56	-24.81	-24.78	-25.99	-25.55
3000	-0.06	-9.02	-9.03	20.23	-24.41	-24.23	-25.90	-25.41
3100	-0.05	-8.91	-8.93	20.01	-24.71	-24.48	-25.87	-25.55
3200	-0.07	-8.80	-8.83	19.64	-24.46	-24.22	-26.33	-25.82
3300	-0.05	-8.68	-8.69	19.55	-24.33	-24.05	-26.10	-25.77
3400	-0.06	-8.59	-8.60	19.50	-24.04	-23.80	-26.15	-25.66
3500	-0.05	-8.50	-8.52	19.89	-24.16	-23.97	-26.00	-25.53
3600	-0.05	-8.44	-8.45	20.52	-24.06	-23.80	-25.69	-25.40
3700	-0.06	-8.39	-8.40	20.75	-24.02	-23.81	-25.73	-25.31
3800	-0.07	-8.38	-8.39	21.63	-24.36	-24.01	-25.41	-25.49
3900	-0.04	-8.37	-8.39	22.00	-24.63	-24.54	-25.89	-25.68
4000	-0.08	-8.42	-8.44	22.07	-25.18	-24.95	-25.96	-26.20
4100	-0.07	-8.43	-8.47	20.98	-25.84	-25.41	-26.81	-26.96
4200	-0.09	-8.47	-8.49	20.71	-26.04	-25.58	-26.38	-26.95
4300	-0.07	-8.49	-8.53	20.56	-27.07	-26.16	-27.22	-28.08
4400	-0.09	-8.54	-8.56	20.56	-26.67	-26.06	-27.39	-28.29
4500	-0.08	-8.57	-8.60	21.02	-28.28	-26.84	-27.71	-28.96
4600	-0.09	-8.63	-8.63	21.93	-28.52	-27.22	-28.12	-29.11
4700	-0.08	-8.68	-8.70	24.31	-29.87	-28.20	-29.24	-30.88
4800	-0.07	-8.76	-8.75	27.27	-29.94	-28.75	-30.86	-32.26
4900	-0.07	-8.78	-8.79	30.45	-30.72	-29.36	-31.15	-33.25
5000	-0.08	-8.98	-8.95	38.75	-32.41	-30.91	-33.95	-36.65
5200	-0.08	-9.19	-9.20	31.68	-32.54	-31.90	-41.00	-40.85
5400	-0.10	-9.51	-9.52	29.05	-35.57	-36.56	-40.61	-32.28
5600	-0.13	-9.89	-9.90	26.52	-31.05	-32.99	-33.00	-29.37
5800	-0.13	-10.42	-10.40	25.50	-28.85	-29.84	-31.59	-28.12
6000	-0.12	-10.78	-10.78	25.55	-26.00	-27.14	-30.96	-27.83
6200	-0.15	-11.27	-11.35	28.17	-23.96	-25.44	-31.68	-28.21
6400	-0.15	-11.92	-11.91	22.71	-21.57	-23.25	-34.20	-29.16
6600	-0.17	-12.61	-12.72	17.90	-20.24	-21.58	-35.99	-28.76
6800	-0.22	-13.68	-13.57	16.29	-18.31	-19.18	-32.03	-26.53
7000	-0.25	-14.68	-14.65	15.17	-17.03	-17.22	-27.02	-24.63

NOTES:

- A. Performance and quality attributes and conditions not expressly stated in this specification document are intended to be excluded and do not form a part of this specification document.
 B. Electrical specifications and performance data contained in this specification document are based on Mini-Circuit's applicable established test performance criteria and measurement instructions.
 C. The parts covered by this specification document are subject to Mini-Circuits standard limited warranty and terms and conditions (collectively, "Standard Terms"); Purchasers of this part are entitled to the rights and benefits contained therein. For a full statement of the Standard Terms and the exclusive rights and remedies thereunder, please visit Mini-Circuits' website at <https://www.minicircuits.com/terms/viewterm.html>



Bi-Directional Coupler

BDCH-10-63+

Typical Performance Data

Test Conditions: Input Power = +5 dbm, Temperature = +105°C, Configuration B.

Freq. (MHz)	I. Loss (dB) In - Out	Coupling (dB)		Directivity (dB) In - Fwd	Return Loss (dB)			
		In - Fwd	Out - Rev		In	Out	Fwd	Rev
1000	-0.03	-16.06	-16.06	21.77	-43.01	-42.45	-37.23	-37.40
1200	-0.03	-14.64	-14.64	22.51	-40.56	-40.09	-36.61	-36.78
1400	-0.03	-13.49	-13.48	23.57	-38.17	-36.91	-35.18	-34.99
1600	-0.03	-12.54	-12.53	24.03	-36.11	-35.15	-33.65	-33.43
1800	-0.03	-11.72	-11.71	22.83	-33.52	-32.99	-31.55	-31.55
2000	-0.04	-11.04	-11.03	21.43	-30.72	-30.61	-29.55	-29.69
2200	-0.05	-10.49	-10.47	20.96	-28.56	-28.53	-27.60	-27.94
2400	-0.06	-10.01	-10.00	21.23	-26.49	-26.55	-26.25	-26.62
2600	-0.06	-9.62	-9.61	21.89	-25.29	-25.37	-25.63	-26.09
2800	-0.06	-9.31	-9.30	21.51	-24.78	-24.81	-25.55	-25.99
3000	-0.06	-9.03	-9.02	19.96	-24.23	-24.41	-25.41	-25.90
3100	-0.06	-8.93	-8.91	19.74	-24.48	-24.71	-25.55	-25.87
3200	-0.06	-8.83	-8.80	19.34	-24.22	-24.46	-25.82	-26.33
3300	-0.05	-8.69	-8.68	19.44	-24.05	-24.33	-25.77	-26.10
3400	-0.06	-8.60	-8.59	19.58	-23.80	-24.04	-25.66	-26.15
3500	-0.06	-8.52	-8.50	20.23	-23.97	-24.16	-25.53	-26.00
3600	-0.05	-8.45	-8.44	21.05	-23.80	-24.06	-25.40	-25.69
3700	-0.07	-8.40	-8.39	21.53	-23.81	-24.02	-25.31	-25.73
3800	-0.07	-8.39	-8.38	22.57	-24.01	-24.36	-25.49	-25.41
3900	-0.05	-8.39	-8.37	23.09	-24.54	-24.63	-25.68	-25.89
4000	-0.07	-8.44	-8.42	23.25	-24.95	-25.18	-26.20	-25.96
4100	-0.09	-8.47	-8.43	21.85	-25.41	-25.84	-26.96	-26.81
4200	-0.09	-8.49	-8.47	21.89	-25.58	-26.04	-26.95	-26.38
4300	-0.09	-8.53	-8.49	21.61	-26.16	-27.07	-28.08	-27.22
4400	-0.10	-8.56	-8.54	22.10	-26.06	-26.67	-28.29	-27.39
4500	-0.09	-8.60	-8.57	23.01	-26.84	-28.28	-28.96	-27.71
4600	-0.10	-8.63	-8.63	24.67	-27.22	-28.52	-29.11	-28.12
4700	-0.08	-8.70	-8.68	27.47	-28.20	-29.87	-30.88	-29.24
4800	-0.07	-8.75	-8.76	29.99	-28.75	-29.94	-32.26	-30.86
4900	-0.08	-8.79	-8.78	35.21	-29.36	-30.72	-33.25	-31.15
5000	-0.07	-8.95	-8.98	44.72	-30.91	-32.41	-36.65	-33.95
5200	-0.08	-9.20	-9.19	43.77	-31.90	-32.54	-40.85	-41.00
5400	-0.09	-9.52	-9.51	36.36	-36.56	-35.57	-32.28	-40.61
5600	-0.11	-9.90	-9.89	27.74	-32.99	-31.05	-29.37	-33.00
5800	-0.12	-10.40	-10.42	24.71	-29.84	-28.85	-28.12	-31.59
6000	-0.11	-10.78	-10.78	23.92	-27.14	-26.00	-27.83	-30.96
6200	-0.14	-11.35	-11.27	28.23	-25.44	-23.96	-28.21	-31.68
6400	-0.15	-11.91	-11.92	23.80	-23.25	-21.57	-29.16	-34.20
6600	-0.18	-12.72	-12.61	18.51	-21.58	-20.24	-28.76	-35.99
6800	-0.23	-13.57	-13.68	15.60	-19.18	-18.31	-26.53	-32.03
7000	-0.26	-14.65	-14.68	14.48	-17.22	-17.03	-24.63	-27.02

NOTES:

- A. Performance and quality attributes and conditions not expressly stated in this specification document are intended to be excluded and do not form a part of this specification document.
- B. Electrical specifications and performance data contained in this specification document are based on Mini-Circuit's applicable established test performance criteria and measurement instructions.
- C. The parts covered by this specification document are subject to Mini-Circuits standard limited warranty and terms and conditions (collectively, "Standard Terms"); Purchasers of this part are entitled to the rights and benefits contained therein. For a full statement of the Standard Terms and the exclusive rights and remedies thereunder, please visit Mini-Circuits' website at <https://www.minicircuits.com/terms/viewterm.html>



Typical Performance Data

Test Conditions: Input Power = +5 dbm, Temperature = +105°C, Configuration C.

Freq. (MHz)	I. Loss (dB) In - Out	Coupling (dB)		Directivity (dB) In - Fwd	Return Loss (dB)			
		In - Fwd	Out - Rev		In	Out	Fwd	Rev
1000	-0.03	-16.07	-16.07	21.79	-37.23	-37.40	-43.01	-42.45
1200	-0.04	-14.65	-14.65	22.56	-36.61	-36.78	-40.56	-40.09
1400	-0.03	-13.49	-13.49	23.75	-35.18	-34.99	-38.17	-36.91
1600	-0.04	-12.54	-12.54	24.09	-33.65	-33.43	-36.11	-35.15
1800	-0.03	-11.72	-11.72	22.84	-31.55	-31.55	-33.52	-32.99
2000	-0.04	-11.04	-11.04	21.29	-29.55	-29.69	-30.72	-30.61
2200	-0.05	-10.49	-10.48	20.79	-27.60	-27.94	-28.56	-28.53
2400	-0.06	-10.01	-10.01	21.04	-26.25	-26.62	-26.49	-26.55
2600	-0.06	-9.63	-9.62	21.64	-25.63	-26.09	-25.29	-25.37
2800	-0.06	-9.32	-9.31	21.29	-25.55	-25.99	-24.78	-24.81
3000	-0.06	-9.03	-9.02	19.76	-25.41	-25.90	-24.23	-24.41
3100	-0.05	-8.94	-8.92	19.47	-25.55	-25.87	-24.48	-24.71
3200	-0.06	-8.83	-8.81	19.08	-25.82	-26.33	-24.22	-24.46
3300	-0.05	-8.70	-8.69	19.07	-25.77	-26.10	-24.05	-24.33
3400	-0.06	-8.61	-8.59	19.18	-25.66	-26.15	-23.80	-24.04
3500	-0.04	-8.52	-8.51	19.56	-25.53	-26.00	-23.97	-24.16
3600	-0.05	-8.46	-8.44	20.27	-25.40	-25.69	-23.80	-24.06
3700	-0.06	-8.40	-8.40	20.53	-25.31	-25.73	-23.81	-24.02
3800	-0.06	-8.40	-8.38	21.43	-25.49	-25.41	-24.01	-24.36
3900	-0.04	-8.39	-8.39	21.72	-25.68	-25.89	-24.54	-24.63
4000	-0.08	-8.45	-8.43	21.71	-26.20	-25.96	-24.95	-25.18
4100	-0.09	-8.47	-8.47	20.60	-26.96	-26.81	-25.41	-25.84
4200	-0.09	-8.50	-8.47	20.35	-26.95	-26.38	-25.58	-26.04
4300	-0.08	-8.52	-8.52	20.21	-28.08	-27.22	-26.16	-27.07
4400	-0.09	-8.56	-8.54	20.26	-28.29	-27.39	-26.06	-26.67
4500	-0.08	-8.59	-8.58	20.84	-28.96	-27.71	-26.84	-28.28
4600	-0.10	-8.63	-8.63	21.99	-29.11	-28.12	-27.22	-28.52
4700	-0.08	-8.69	-8.68	24.67	-30.88	-29.24	-28.20	-29.87
4800	-0.07	-8.75	-8.75	28.07	-32.26	-30.86	-28.75	-29.94
4900	-0.08	-8.78	-8.77	31.39	-33.25	-31.15	-29.36	-30.72
5000	-0.08	-8.97	-8.97	39.43	-36.65	-33.95	-30.91	-32.41
5200	-0.07	-9.21	-9.18	33.05	-40.85	-41.00	-31.90	-32.54
5400	-0.09	-9.52	-9.51	30.01	-32.28	-40.61	-36.56	-35.57
5600	-0.09	-9.91	-9.88	27.34	-29.37	-33.00	-32.99	-31.05
5800	-0.11	-10.42	-10.42	26.67	-28.12	-31.59	-29.84	-28.85
6000	-0.09	-10.82	-10.81	27.92	-27.83	-30.96	-27.14	-26.00
6200	-0.11	-11.38	-11.30	29.71	-28.21	-31.68	-25.44	-23.96
6400	-0.11	-11.92	-11.93	23.21	-29.16	-34.20	-23.25	-21.57
6600	-0.12	-12.71	-12.62	18.12	-28.76	-35.99	-21.58	-20.24
6800	-0.13	-13.54	-13.70	16.15	-26.53	-32.03	-19.18	-18.31
7000	-0.16	-14.63	-14.70	15.17	-24.63	-27.02	-17.22	-17.03

NOTES:

- A. Performance and quality attributes and conditions not expressly stated in this specification document are intended to be excluded and do not form a part of this specification document.
 B. Electrical specifications and performance data contained in this specification document are based on Mini-Circuit's applicable established test performance criteria and measurement instructions.
 C. The parts covered by this specification document are subject to Mini-Circuits standard limited warranty and terms and conditions (collectively, "Standard Terms"); Purchasers of this part are entitled to the rights and benefits contained therein. For a full statement of the Standard Terms and the exclusive rights and remedies thereunder, please visit Mini-Circuits' website at <https://www.minicircuits.com/terms/viewterm.html>

Bi-Directional Coupler

BDCH-10-63+

Typical Performance Data

Test Conditions: Input Power = +5 dbm, Temperature = +105°C, Configuration D.

Freq. (MHz)	I. Loss (dB) In - Out	Coupling (dB)		Directivity (dB) In - Fwd	Return Loss (dB)			
		In - Fwd	Out - Rev		In	Out	Fwd	Rev
1000	-0.03	-16.07	-16.07	21.76	-37.40	-37.23	-42.45	-43.01
1200	-0.04	-14.65	-14.65	22.45	-36.78	-36.61	-40.09	-40.56
1400	-0.04	-13.49	-13.49	23.40	-34.99	-35.18	-36.91	-38.17
1600	-0.04	-12.54	-12.54	24.01	-33.43	-33.65	-35.15	-36.11
1800	-0.04	-11.72	-11.72	23.04	-31.55	-31.55	-32.99	-33.52
2000	-0.05	-11.04	-11.04	21.62	-29.69	-29.55	-30.61	-30.72
2200	-0.06	-10.48	-10.49	21.00	-27.94	-27.60	-28.53	-28.56
2400	-0.06	-10.01	-10.01	21.03	-26.62	-26.25	-26.55	-26.49
2600	-0.06	-9.62	-9.63	21.63	-26.09	-25.63	-25.37	-25.29
2800	-0.06	-9.31	-9.32	21.46	-25.99	-25.55	-24.81	-24.78
3000	-0.06	-9.02	-9.03	20.11	-25.90	-25.41	-24.41	-24.23
3100	-0.05	-8.92	-8.94	19.89	-25.87	-25.55	-24.71	-24.48
3200	-0.06	-8.81	-8.83	19.48	-26.33	-25.82	-24.46	-24.22
3300	-0.05	-8.69	-8.70	19.53	-26.10	-25.77	-24.33	-24.05
3400	-0.06	-8.59	-8.61	19.65	-26.15	-25.66	-24.04	-23.80
3500	-0.05	-8.51	-8.52	20.09	-26.00	-25.53	-24.16	-23.97
3600	-0.05	-8.44	-8.46	20.76	-25.69	-25.40	-24.06	-23.80
3700	-0.06	-8.40	-8.40	21.17	-25.73	-25.31	-24.02	-23.81
3800	-0.06	-8.38	-8.40	22.22	-25.41	-25.49	-24.36	-24.01
3900	-0.05	-8.39	-8.39	22.94	-25.89	-25.68	-24.63	-24.54
4000	-0.08	-8.43	-8.45	23.44	-25.96	-26.20	-25.18	-24.95
4100	-0.08	-8.47	-8.47	22.39	-26.81	-26.96	-25.84	-25.41
4200	-0.09	-8.47	-8.50	22.73	-26.38	-26.95	-26.04	-25.58
4300	-0.07	-8.52	-8.52	22.39	-27.22	-28.08	-27.07	-26.16
4400	-0.08	-8.54	-8.56	22.98	-27.39	-28.29	-26.67	-26.06
4500	-0.08	-8.58	-8.59	23.76	-27.71	-28.96	-28.28	-26.84
4600	-0.08	-8.63	-8.63	25.27	-28.12	-29.11	-28.52	-27.22
4700	-0.07	-8.68	-8.69	27.84	-29.24	-30.88	-29.87	-28.20
4800	-0.05	-8.75	-8.75	30.16	-30.86	-32.26	-29.94	-28.75
4900	-0.07	-8.77	-8.78	35.40	-31.15	-33.25	-30.72	-29.36
5000	-0.06	-8.97	-8.97	50.03	-33.95	-36.65	-32.41	-30.91
5200	-0.05	-9.18	-9.21	54.99	-41.00	-40.85	-32.54	-31.90
5400	-0.07	-9.51	-9.52	39.84	-40.61	-32.28	-35.57	-36.56
5600	-0.07	-9.88	-9.91	29.91	-33.00	-29.37	-31.05	-32.99
5800	-0.09	-10.42	-10.42	26.11	-31.59	-28.12	-28.85	-29.84
6000	-0.08	-10.81	-10.82	24.02	-30.96	-27.83	-26.00	-27.14
6200	-0.10	-11.30	-11.38	26.28	-31.68	-28.21	-23.96	-25.44
6400	-0.11	-11.93	-11.92	22.99	-34.20	-29.16	-21.57	-23.25
6600	-0.11	-12.62	-12.71	18.97	-35.99	-28.76	-20.24	-21.58
6800	-0.13	-13.70	-13.54	15.90	-32.03	-26.53	-18.31	-19.18
7000	-0.16	-14.70	-14.63	14.27	-27.02	-24.63	-17.03	-17.22

NOTES:

- A. Performance and quality attributes and conditions not expressly stated in this specification document are intended to be excluded and do not form a part of this specification document.
- B. Electrical specifications and performance data contained in this specification document are based on Mini-Circuit's applicable established test performance criteria and measurement instructions.
- C. The parts covered by this specification document are subject to Mini-Circuits standard limited warranty and terms and conditions (collectively, "Standard Terms"); Purchasers of this part are entitled to the rights and benefits contained therein. For a full statement of the Standard Terms and the exclusive rights and remedies thereunder, please visit Mini-Circuits' website at <https://www.minicircuits.com/terms/viewterm.html>



Typical Performance Graphs

Test Conditions: Input Power = +5 dbm, Configuration A.

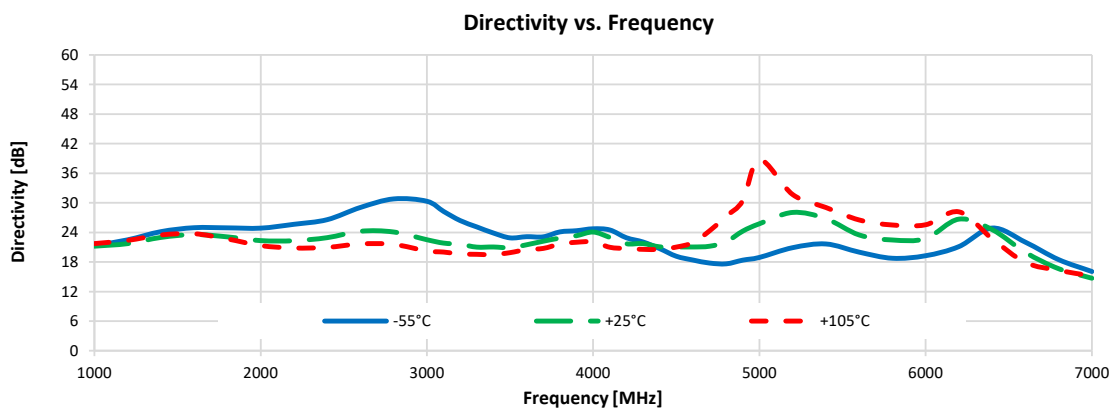
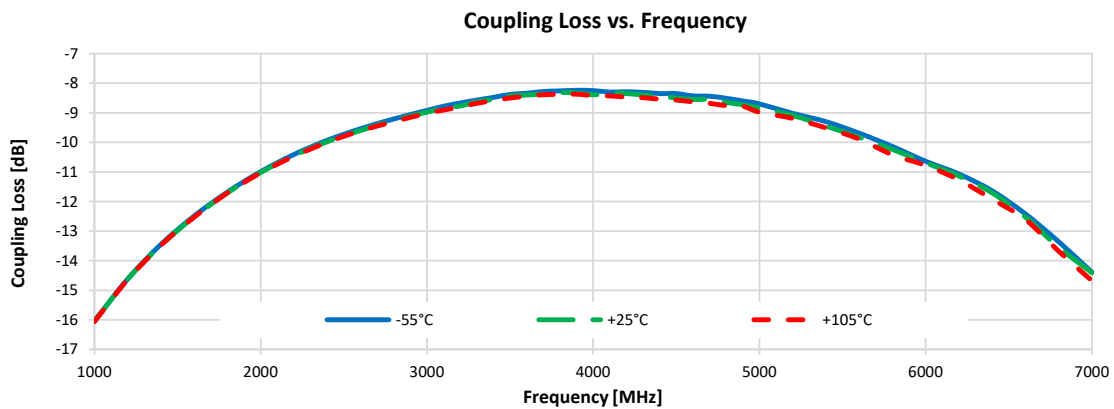
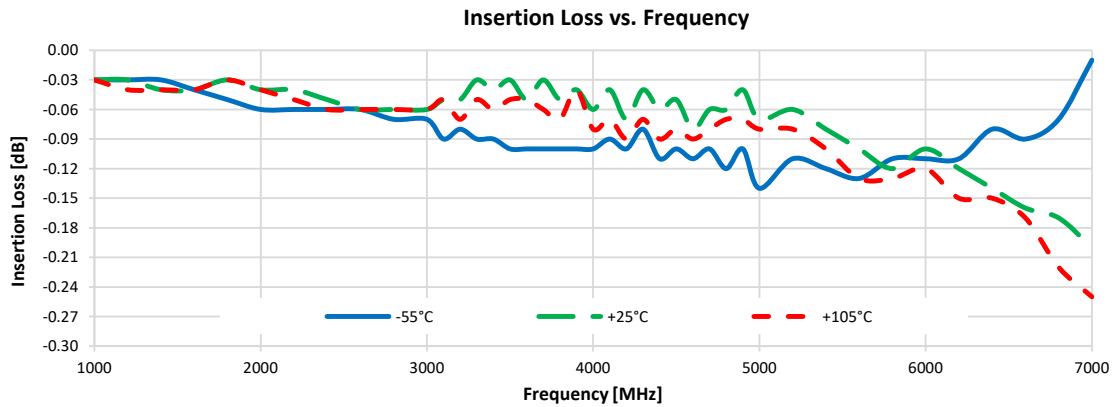

Typical Performance Graphs

Test Conditions: Input Power = +5 dbm, Configuration B.

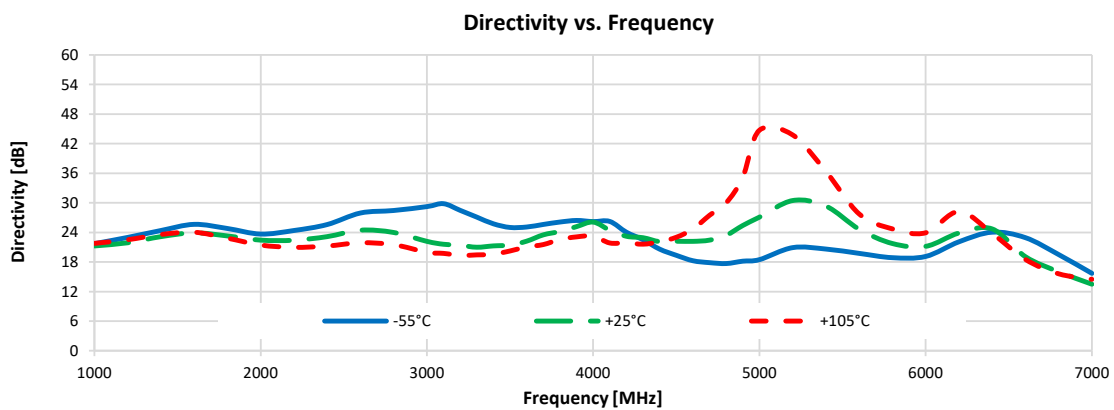
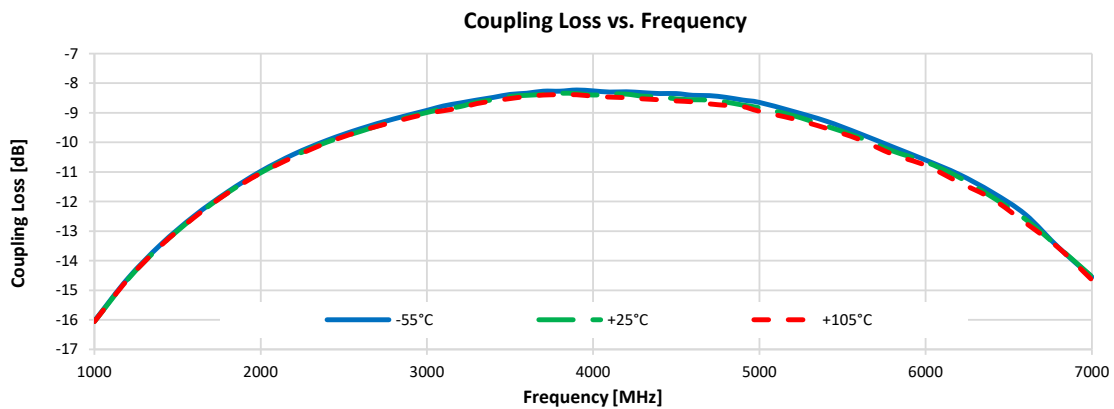
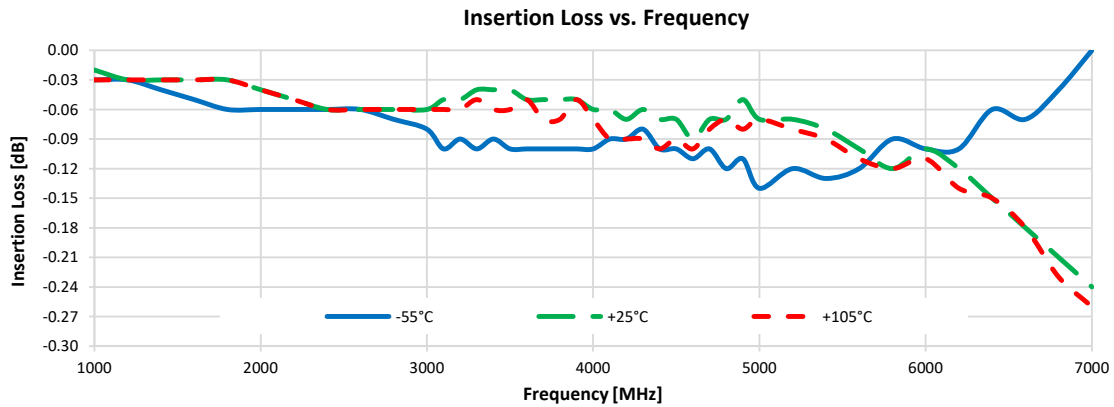

Typical Performance Graphs

Test Conditions: Input Power = +5 dbm, Configuration C.

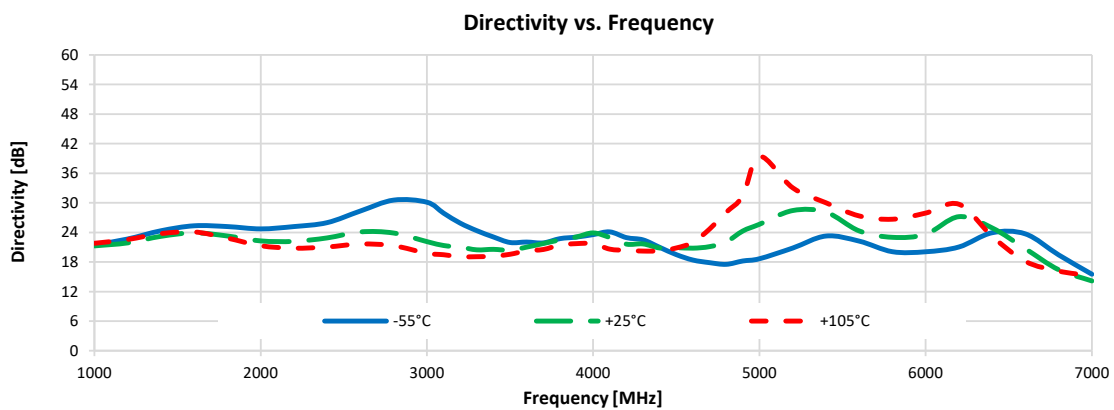
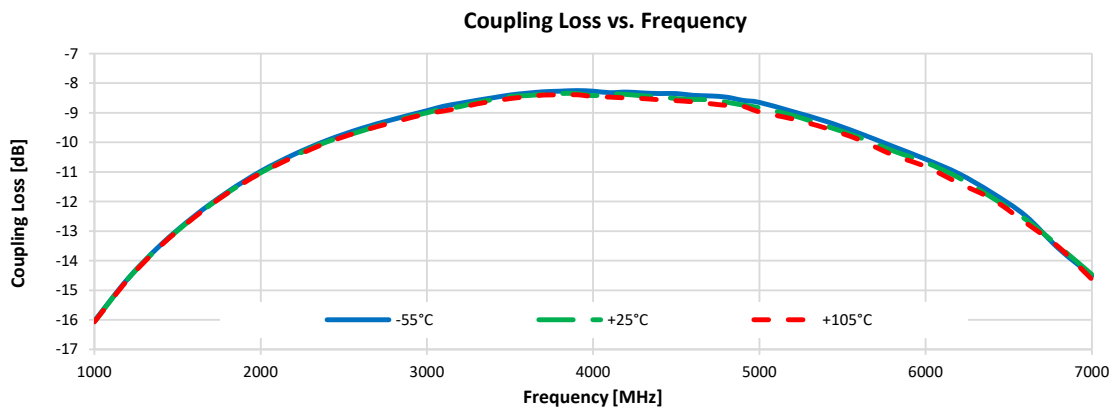
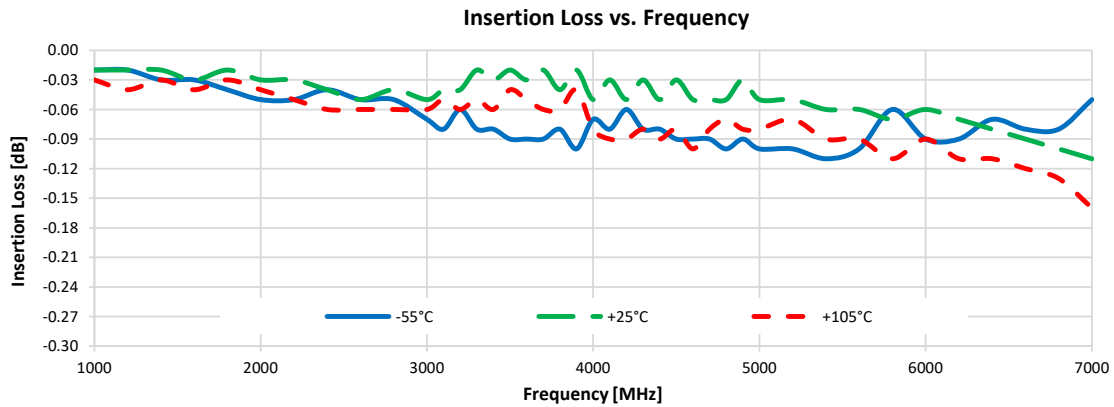

Typical Performance Graphs

Test Conditions: Input Power = +5 dbm, Configuration D.

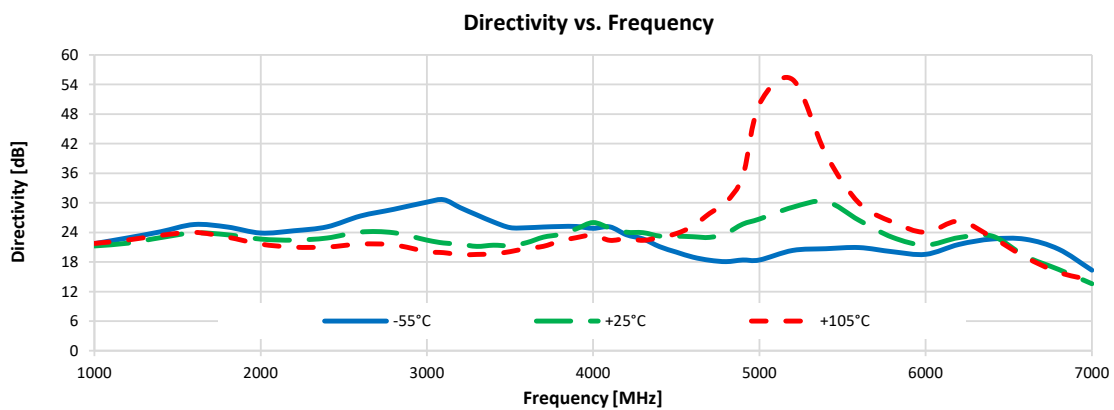
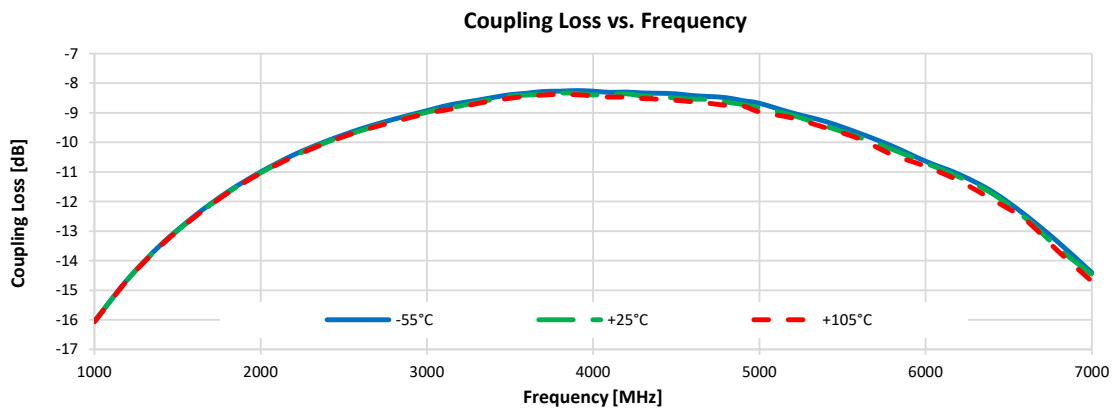
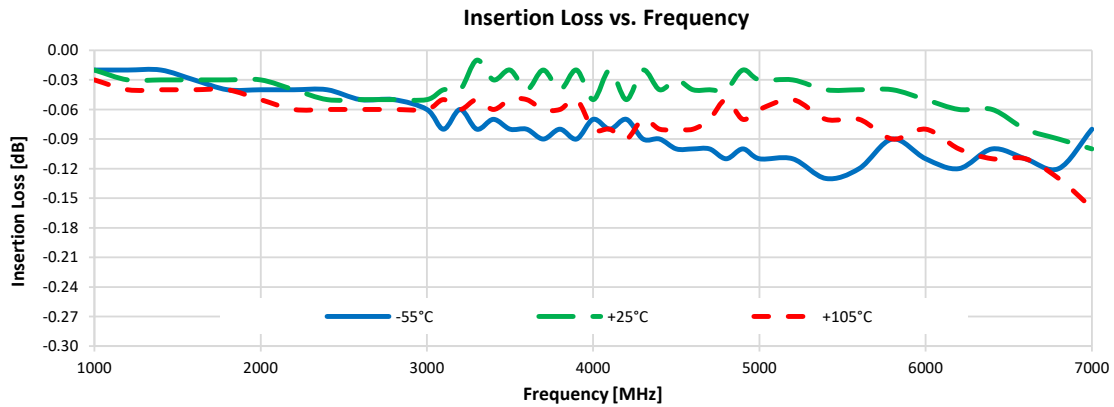

Typical Performance Graphs

Test Conditions: Input Power = +5 dbm, Configuration A.

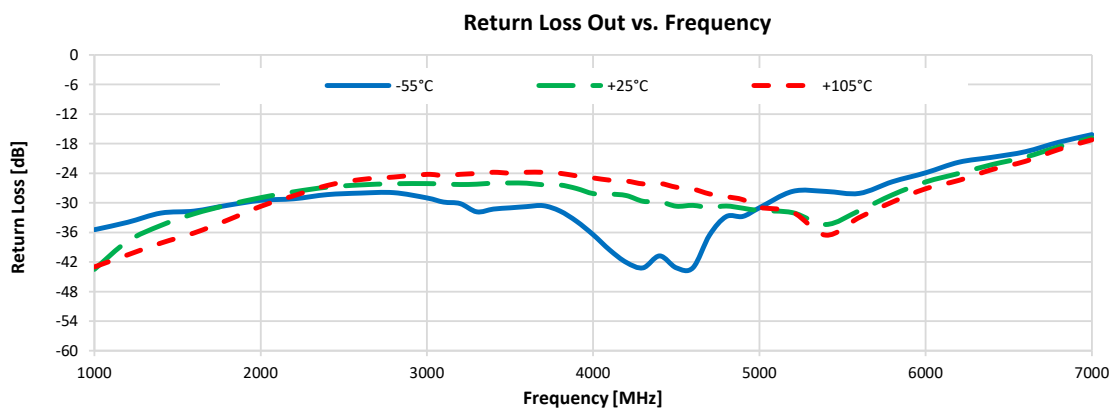
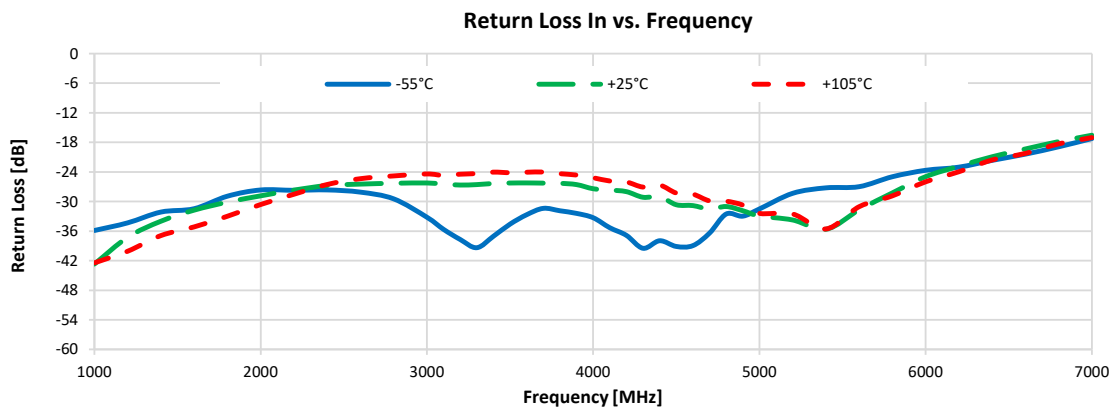
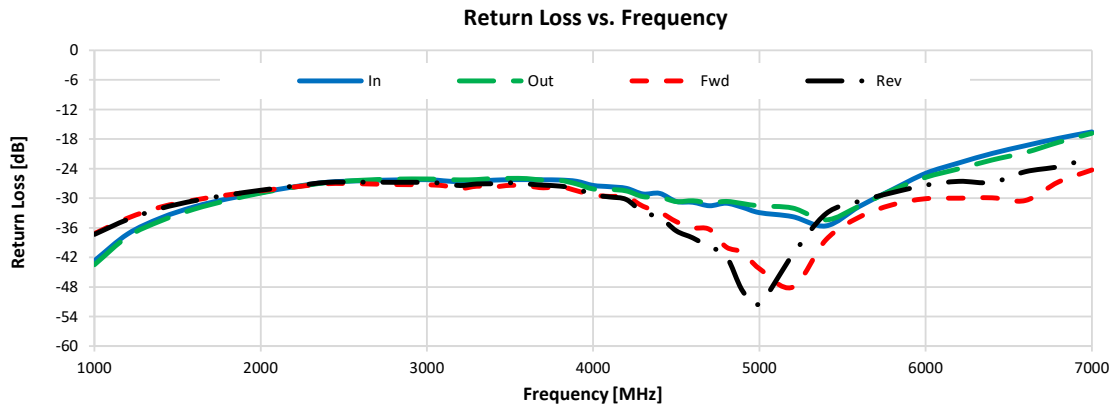

Return Loss Forward vs. Frequency

NOTES:

- A. Performance and quality attributes and conditions not expressly stated in this specification document are intended to be excluded and do not form a part of this specification document.
- B. Electrical specifications and performance data contained in this specification document are based on Mini-Circuit's applicable established test performance criteria and measurement instructions.
- C. The parts covered by this specification document are subject to Mini-Circuits standard limited warranty and terms and conditions (collectively, "Standard Terms"); Purchasers of this part are entitled to the rights and benefits contained therein. For a full statement of the Standard Terms and the exclusive rights and remedies thereunder, please visit Mini-Circuits' website at <https://www.minicircuits.com/terms/viewterm.html>



Typical Performance Graphs

Test Conditions: Input Power = +5 dbm, Configuration A.

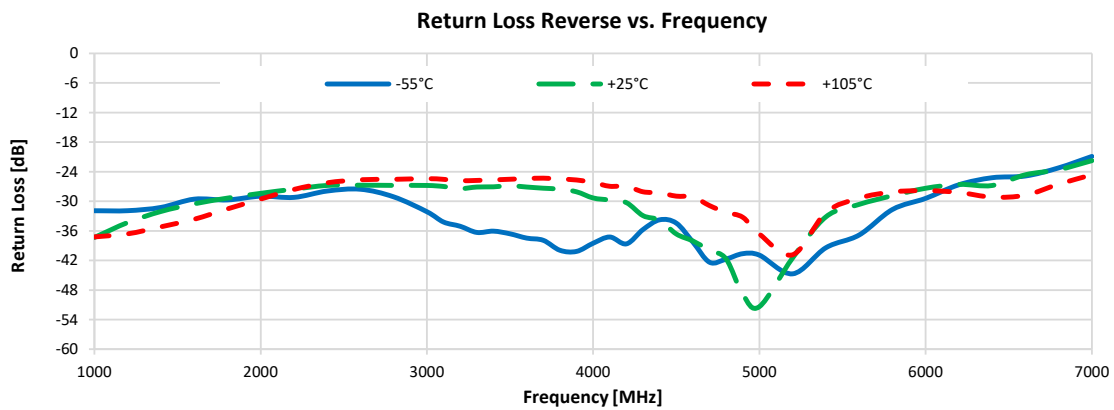
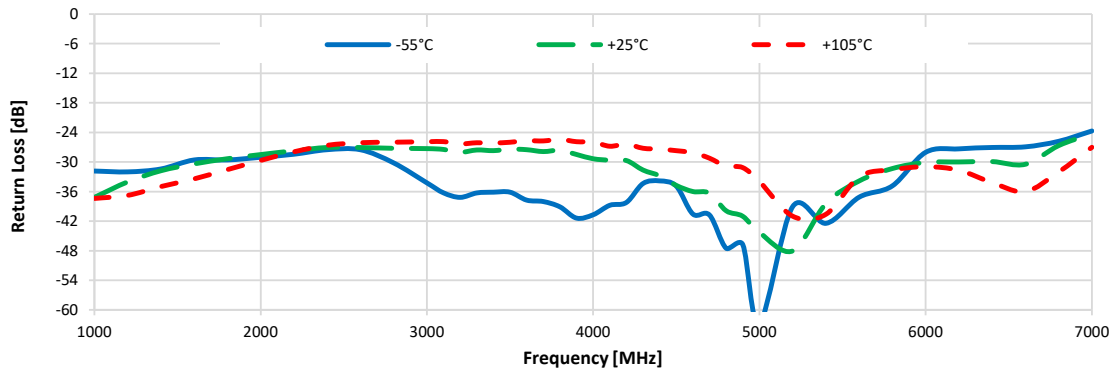

NOTES:

- A. Performance and quality attributes and conditions not expressly stated in this specification document are intended to be excluded and do not form a part of this specification document.
- B. Electrical specifications and performance data contained in this specification document are based on Mini-Circuit's applicable established test performance criteria and measurement instructions.
- C. The parts covered by this specification document are subject to Mini-Circuits standard limited warranty and terms and conditions (collectively, "Standard Terms"); Purchasers of this part are entitled to the rights and benefits contained therein. For a full statement of the Standard Terms and the exclusive rights and remedies thereunder, please visit Mini-Circuits' website at <https://www.minicircuits.com/terms/viewterm.html>



Outline Dimensions

PQ2099-1

TOP SIDE

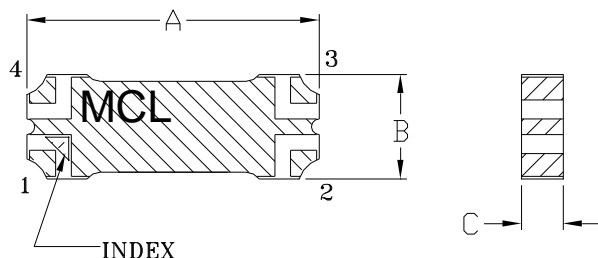

BOTTOM SIDE

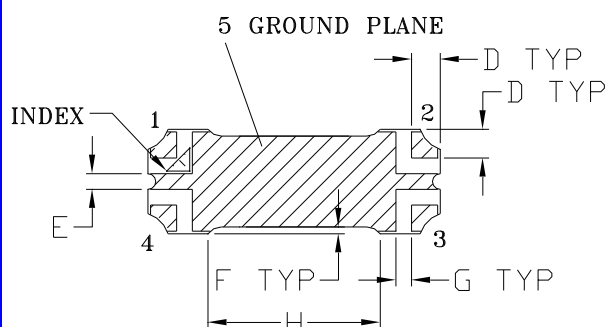

PCB LAND PATTERN

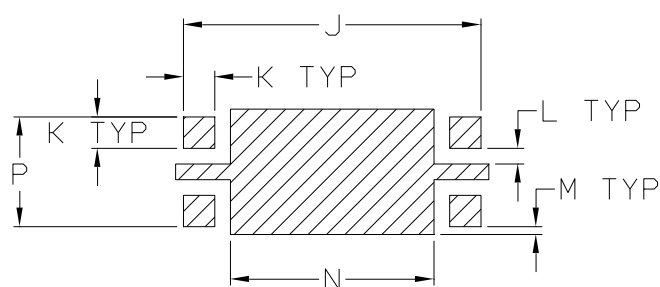

 METALLIZATION  SOLDER RESIST

CASE#	A	B	C	D	E	F	G	H	J	K	L	M	N	P	WT. GRAMS
PQ2099-1	.560 (14.22)	.200 (5.08)	.080 (2.03)	.055 (1.40)	.030 (0.76)	.013 (0.33)	.030 (0.76)	.330 (8.38)	.570 (14.48)	.060 (1.52)	.030 (0.76)	.015 (0.38)	.390 (9.91)	.210 (5.33)	1.5

Dimensions are in inches (mm). Tolerances: 2PL. +/- .03; 3PL. +/- .010

Notes:

1. Base material: Printed wiring laminate.
2. Termination finish:
For RoHS Cases, all models (+) suffix: 2-5 µinch (.05-.13 microns) Immersion Gold.
For RoHS-5 Cases, all models no (+) suffix: Tin-Lead plate.



INTERNET <http://www.minicircuits.com>

P.O. Box 350166, Brooklyn, New York 11235-0003 (718) 934-4500 Fax (718) 332-4661

Distribution Centers NORTH AMERICA 800-654-7949 • 417-335-5935 • Fax 417-335-5945 • EUROPE 44-1252-832600 • Fax 44-1252-837010

Mini-Circuits ISO 9001 & ISO 14001 Certified

Tape & Reel Packaging TR-F48

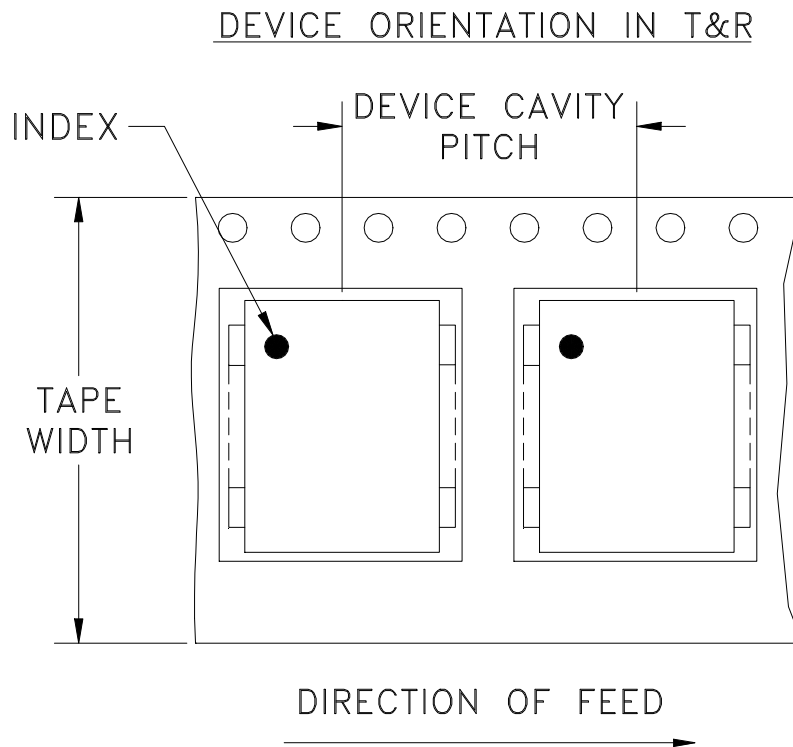

Tape Width, mm	Device Cavity Pitch, mm	Reel Size, inches	Devices per Reel
24	12	13	1000

Mini-Circuits carrier tape materials provide protection from ESD (Electro-Static Discharge) during handling and transportation. Tapes are static dissipative and comply with industry standards EIA-481/EIA-541.

Go to: www.minicircuits.com/pages/pdfs/tape.pdf



INTERNET <http://www.minicircuits.com>

P.O. Box 350166, Brooklyn, New York 11235-0003 (718) 934-4500 Fax (718) 332-4661

Distribution Centers NORTH AMERICA 800-654-7949 • 417-335-5935 • Fax 417-335-5945 • EUROPE 44-1252-832600 • Fax 44-1252-837010

Mini-Circuits ISO 9001 & ISO 14001 Certified

THIRD ANGLE PROJECTION

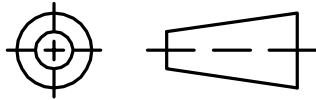

REVISIONS

REV	ECN No.	DESCRIPTION	DATE	DR	AUTH
OR	M153641	NEW RELEASE	12/15	DK	YB
A	M156950	CHANGE PIN CONNECTION CODE	06/16	DK	YB
B	M159071	CH. MATERIAL, DIELECT.THK&COP. WEIGHT	12/16	DK	YB
B	R91223	CH. MATERIAL, DIELECT.THK&COP. WEIGHT	12/16	DK	YB

SUGGESTED MOUNTING CONFIGURATION

FOR PQ2099/2099-1 CASE STYLE 04DC01 PIN CONNECTION, 50 OHM

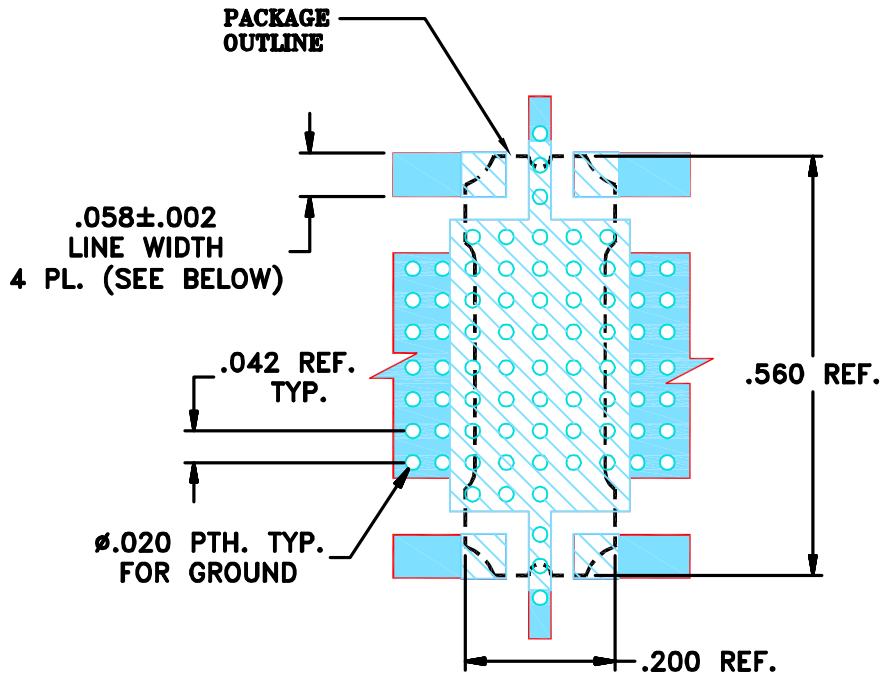

NOTES:

- TRACE WIDTH IS SHOWN FOR ROGERS R05880 WITH DIELECTRIC THICKNESS. $.020^{\circ} \pm .0015^{\circ}$. COPPER: 1 OZ. EACH SIDE. FOR OTHER MATERIALS TRACE WIDTH MAY NEED TO BE MODIFIED.
- BOTTOM SIDE OF THE PCB IS CONTINUOUS GROUND PLANE.

DENOTES PCB COPPER LAYOUT WITH SMOBC (SOLDER MASK OVER BARE COPPER)

DENOTES COPPER LAND PATTERN FREE OF SOLDERMASK

UNLESS OTHERWISE SPECIFIED	INITIALS	DATE
DIMENSIONS ARE IN INCHES	DRAWN DK (RAVON)	20 DEC 15
TOLERANCES ON:	CHECKED HH (RAVON)	20 DEC 15
2 PL. DECIMALS ±	APPROVED YB (RAVON)	20 DEC 15
3 PL. DECIMALS ± .005		
ANGLES ±		
FRACTIONS ±		



Mini-Circuits®

13 Neptune Avenue
Brooklyn NY 11235

PL FOR MBD PQ2099
TB-864+ (50 Ω)

SIZE A	CODE IDENT 15542	DRAWING NO: 98-PL-470	REV: B
FILE: 98PL470(B)		SCALE: 4:1	SHEET: 1 OF 1

THIS DOCUMENT AND ITS CONTENTS ARE THE PROPERTY OF MINI-CIRCUITS. EXCEPT FOR USE EXPRESSLY GRANTED, IN WRITING, TO ITS VENDORS, VENDEE AND THE UNITED STATES GOVERNMENT, MINI-CIRCUITS RESERVES ALL PROPRIETARY DESIGN, USE, MANUFACTURING AND REPRODUCTION RIGHTS THERE TO. THESE CONTENTS SHALL NOT BE USED, DUPLICATED OR DISCLOSED TO ANY OUTSIDE PARTY, IN WHOLE OR IN PART, WITHOUT WRITTEN PERMISSION OF MINI-CIRCUITS.

Evaluation Board and Circuit

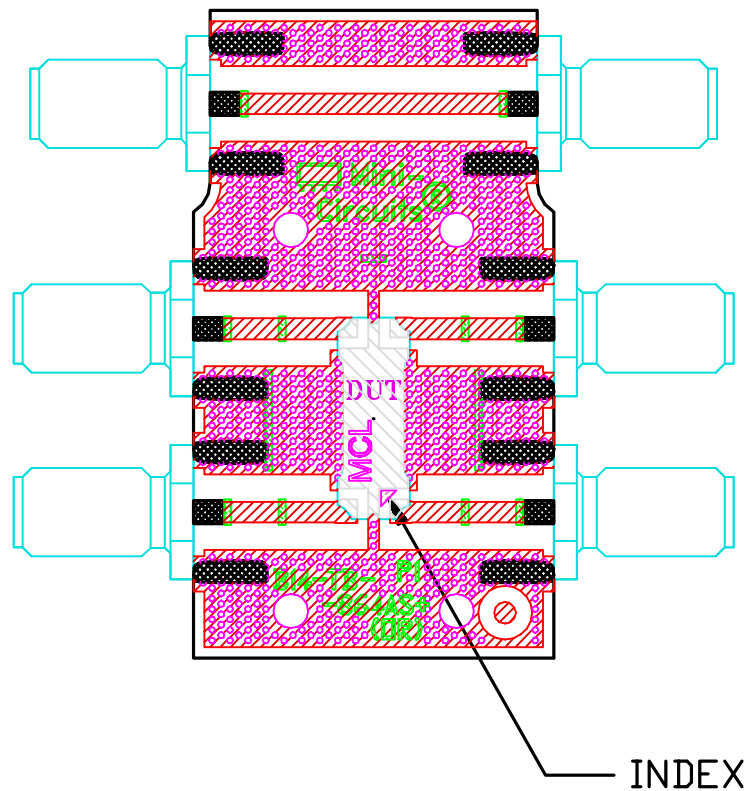

TB-864+

NOTES:

1. SMA FEMALE CONNECTORS.
2. PCB MATERIAL: ROGERS RT/DUROID 5880 OR EQUIVALENT,
DIELECTRIC CONSTANT=2.2, DIELECTRIC THICKNESS=.020 INCH.

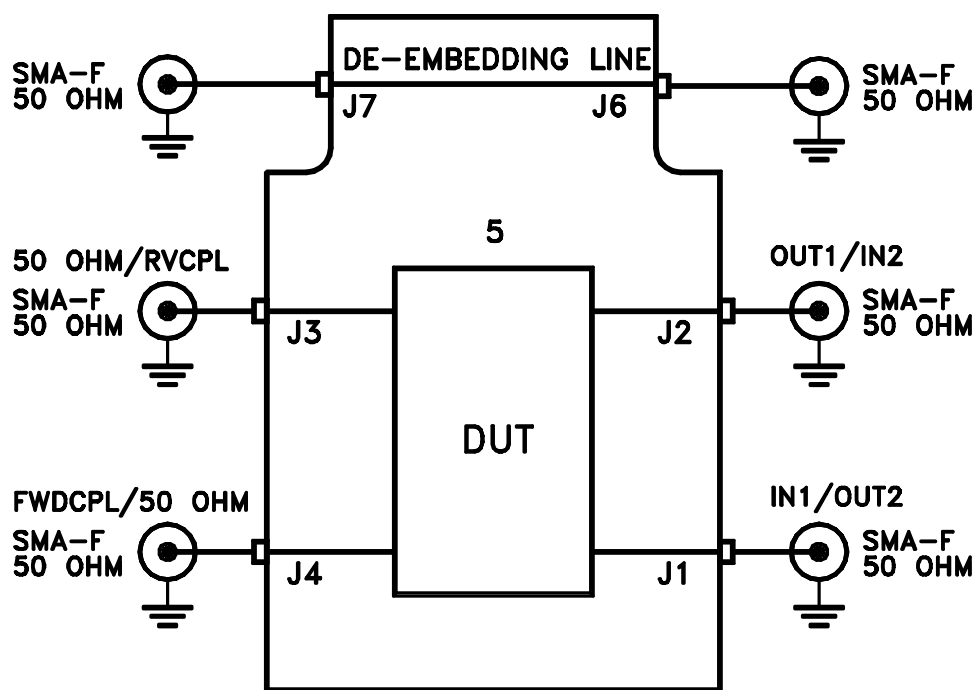

TB-864+
Schematic Diagram



All Mini-Circuits products are manufactured under exacting quality assurance and control standards, and are capable of meeting published specifications after being subjected to any or all of the following physical and environmental test.

Specification	Test/Inspection Condition	Reference/Spec
Operating Temperature	-55° to 105° C Case Environment	Individual Model Data Sheet
Storage Temperature	-55° to 105°C Ambient Environment	Individual Model Data Sheet
Humidity	90 to 95% RH, 240 hours, 50°C	MIL-STD-202, Method 103, Condition A, Except 50°C and end-point electrical test done within 12 hours
Thermal Shock	-55° to 100°C, 100 cycles	MIL-STD-202, Method 107, Condition A-3, except +100°C
Solder Reflow Heat	Sn-Pb Eutectic Process 225°C peak Pb-Free Process 245° - 250°C peak	J-STD-020C, Table 4-1, 4-2 and 5-2, Figure 5-1
Solderability	10X Magnification	J-STD-002, Para 4.2.5, Test S, 95% Coverage
Vibration (high Frequency)	20g peak, 10-2000 Hz, 12 times in each of three perpendicular directions (total 36)	MIL-STD-883, Method 2007.3, Condition A
Mechanical Shock	50g, 11 ms, 1/2-sine, 18 shocks: 3 each direction, each of 3 axes	MIL-STD-202, Method 213, Condition A
Marking Resistance to Solvents	Isopropyl alcohol + mineral spirits at 25°C; terpene defluxer at 25°C; distilled water + proylene glycol monomethyl ether + monoethanolamine at 63°C to 70°C	MIL-STD-202, Method 215