



CERAMIC

Bandpass Filter & Balun **BBFCG2-3650+**

50Ω 3150 to 4150 MHz

THE BIG DEAL

- Tiny size, (0805)
- Compact design includes Balun & Filter in one package
- Low cost
- Temperature stable
- Hermetically sealed



Generic photo used for illustration purposes only

CASE STYLE: GE0805C-15

+RoHS Compliant

The +Suffix identifies RoHS Compliance. See our website for methodologies and qualifications

APPLICATIONS

- Telecommunications
- 5G sub 6GHz

PRODUCT OVERVIEW

Mini-Circuits' BBFCG2-3650+ is a tiny ceramic RF balun filter with an impedance ratio of 1:2, covering a variety of wireless communications applications from 3150 to 4150 MHz. This model provides low insertion loss, low phase unbalance (relative to 180°), low amplitude unbalance. Fabricated using LTCC technology, the unit comes housed in a tiny, rugged ceramic package (0.079" x 0.049" x 0.037") suitable for harsh operating environments.

KEY FEATURES

Feature	Advantages
Compact Design	Integrates filter and balun in one tiny package
Tiny size, 0805	Accommodates tight space requirements for dense PCB layouts.
LTCC construction	LTCC process enables tiny size and low cost, suitable for high-volume production. Rugged ceramic package provides excellent reliability in harsh operating environments.



CERAMIC

Bandpass Filter & Balun **BBFCG2-3650+**

Mini-Circuits

ELECTRICAL SPECIFICATIONS AT 25°C

Parameter	F#	Frequency (MHz)	Min.	Typ.	Max.	Units
Impedance Ratio	—	—	2			
Insertion Loss*	F1-F2	3150 - 4150	—	3.2	4	dB
Return Loss	Unbalanced Port	F1-F2	8.5	11	—	dB
	Balanced Port*	F1-F2	8.5	11	—	
Stopband Rejection	DC-F3	DC - 2598	15	25	—	dB
		2598 - 2698	12	23	—	
	F4-F5	4847 - 5547	20	—	—	
		6099 - 10048	27	35	—	
Amplitude Unbalance ±	F1-F2	3150 - 4150	-1.5	—	1.5	dB
Phase Unbalance	F1-F2	3150 - 4150	-13	—	13	Degree
CMRR	F1-F2	3150 - 4150	—	20	—	dB

* Single ended - Differential (2-port) measurement.

MAXIMUM RATINGS

Parameter	Ratings
Operating Temperature	-55°C to 125°C
Storage Temperature	-55°C to 125°C
RF Power Input	0.5W at 25°C

TYPICAL FREQUENCY RESPONSE

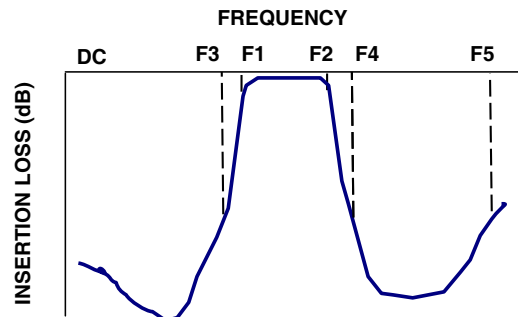

DC INTERFACE TABLE

Unbalance Port - GND	DC short
Unbalance Port - Balance Ports	DC open
Balance port - GND	DC open
Balance port-Balance Port	DC short

FUNCTIONAL SCHEMATIC

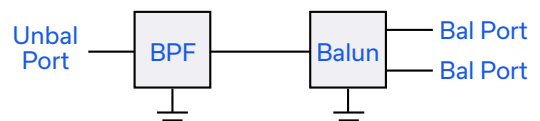



CERAMIC

Bandpass Filter & Balun **BBFCG2-3650+**

PAD CONNECTIONS

UNBALANCED PORT	1
BALANCED PORT	4,6
GROUND	2,3,7,8
NOT CONNECT OR GND	5

PRODUCT MARKING: N/A

DEMO BOARD MCL P/N: TB-BBFCG2-3650+
SUGGESTED PCB LAYOUT (PL-724)

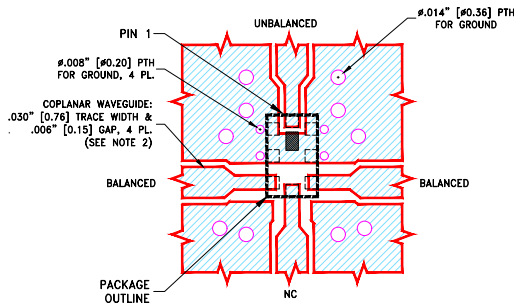

STACK-UP DIAGRAM

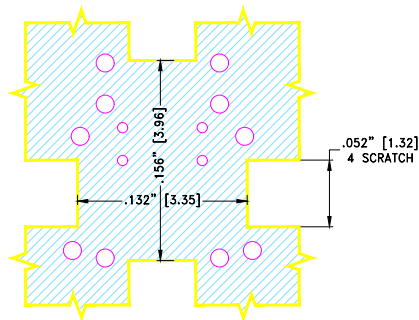
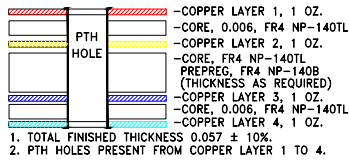

TOP VIEW TO LAYER 2

NOTES:

- PCB IS MULTILAYER PCB, SEE STACK-UP DIAGRAM.
- TRACE WIDTH & GAP PARAMETERS ARE SHOWN FOR FR4 NP-140TL WITH DIELECTRIC THICKNESS .006" ± .0005"; COPPER: 1 OZ. FOR OTHER MATERIALS TRACE WIDTH AND GAP MAY NEED TO BE MODIFIED.
- COPPER LAYERS 3,4 OF THE PCB IS CONTINUOUS GROUND PLANES.

DENOTES COPPER LAND PATTERN FREE OF SOLDER MASK.

OUTLINE DRAWING

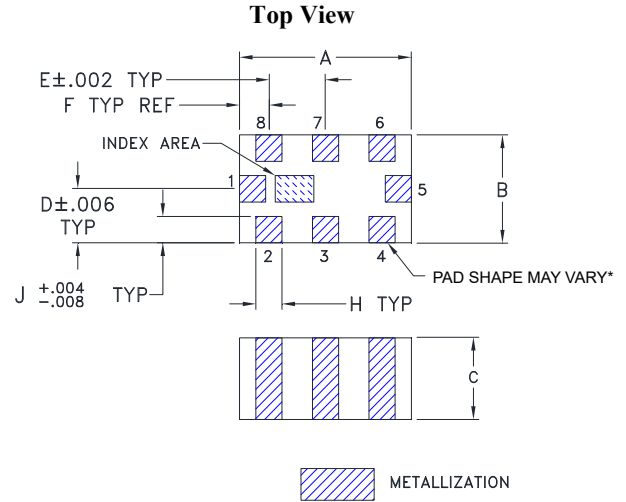

*During the manufacturing process, the pad shape may not be rectangular and may take on a more semi-circle shape. However, the pad dimensions reflect this, with the pad shape being within the specified lengths. The metallization compensates accordingly and so performance will not be affected. In addition, solderability will not be influenced by the pad shape.

OUTLINE DIMENSIONS (Inches mm)

A	B	C	D	E	F	G	H	J	wt
.079	.049	.037	.025	.026	.014	.110	.012	.010	grams
2.00	1.25	0.95	0.63	0.65	0.35	2.80	0.30	0.25	.008



CERAMIC

Bandpass Filter & Balun **BBFCG2-3650+**

Mini-Circuits

TYPICAL PERFORMANCE DATA

Frequency (MHz)	Insertion Loss (dB)	Return Loss (dB)	Amplitude Unbalance (dB)	Phase Unbalance (Deg.)
10	69.43	0.71	4.09	169.46
1000	37.28	0.64	6.21	24.04
2598	30.78	0.43	2.65	2.98
2698	26.96	0.76	2.32	16.12
3150	1.66	16.73	1.32	4.48
4150	1.78	16.01	1.01	8.32
4847	22.80	0.93	2.78	20.91
5547	46.74	0.26	3.13	67.08
6099	41.95	0.02	3.16	15.29
7000	48.75	0.04	1.48	173.95
8000	50.68	0.71	3.63	179.67
10048	52.70	0.34	0.99	176.46

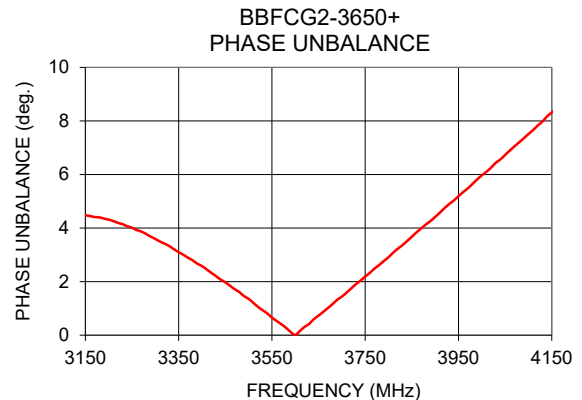
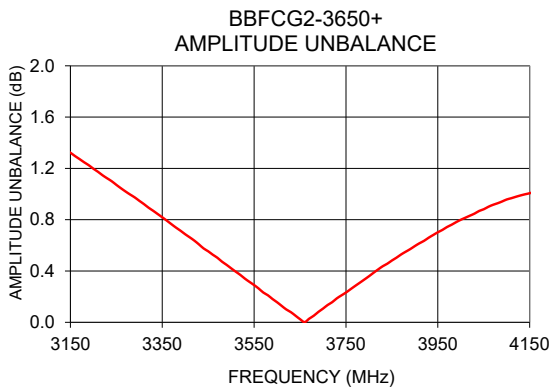
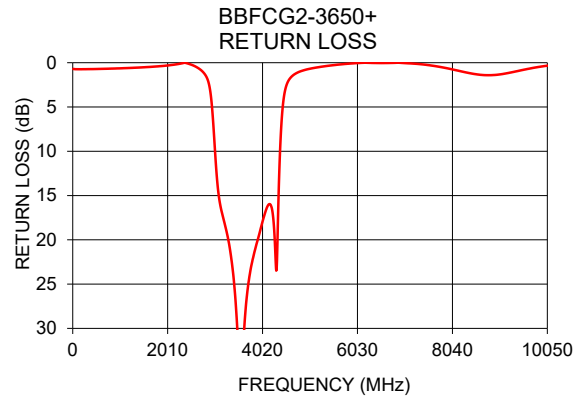
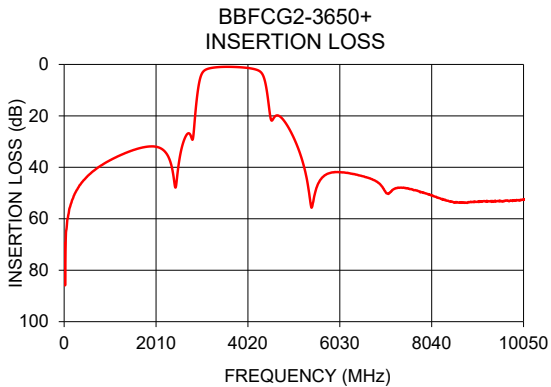

- NOTES**
- A. Performance and quality attributes and conditions not expressly stated in this specification document are intended to be excluded and do not form a part of this specification document.
 - B. Electrical specifications and performance data contained in this specification document are based on Mini-Circuit's applicable established test performance criteria and measurement instructions.
 - C. The parts covered by this specification document are subject to Mini-Circuits standard limited warranty and terms and conditions (collectively, "Standard Terms"); Purchasers of this part are entitled to the rights and benefits contained therein. For a full statement of the standard. Terms and the exclusive rights and remedies thereunder, please visit Mini-Circuits' website at www.minicircuits.com/MCLStore/terms.jsp



Ceramic Bandpass Filter & Balun BBFCG2-3650+

Typical Performance Data

FREQUENCY (MHz)	INSERTION LOSS (dB)	RETURN LOSS (dB)	AMPLITUDE UNBALANCE (dB)	PHASE UNBALANCE (deg.)
10	69.43	0.71	4.09	169.46
100	57.84	0.73	1.21	6.51
500	43.67	0.71	4.58	27.60
1000	37.28	0.64	6.21	24.04
1500	33.36	0.52	5.55	19.98
2000	31.98	0.32	4.30	18.06
2200	33.79	0.18	3.50	17.23
2400	44.46	0.04	1.57	37.66
2598	30.78	0.43	2.65	2.98
2800	29.18	1.32	6.43	25.56
3000	4.09	8.88	1.72	3.18
3100	2.01	15.31	1.44	4.43
3150	1.66	16.73	1.32	4.48
3200	1.44	17.81	1.20	4.31
3250	1.28	18.89	1.07	4.01
3300	1.17	20.16	0.95	3.59
3350	1.08	21.81	0.82	3.10
3400	1.01	23.97	0.69	2.58
3450	0.97	27.08	0.55	1.98
3500	0.94	31.71	0.42	1.36
3550	0.93	36.75	0.29	0.66
3600	0.93	32.95	0.16	0.00
3650	0.94	28.57	0.02	0.73
3700	0.97	25.75	0.11	1.44
3750	1.00	23.87	0.23	2.19
3800	1.05	22.48	0.36	2.91
3850	1.10	21.33	0.48	3.68
3900	1.16	20.32	0.59	4.41
3950	1.24	19.36	0.70	5.19
4000	1.34	18.32	0.80	5.97
4050	1.45	17.37	0.88	6.73
4100	1.60	16.53	0.96	7.51
4150	1.78	16.01	1.01	8.32
4210	2.07	16.32	1.04	9.28
4400	7.06	8.77	0.51	13.97
4600	20.45	1.78	3.65	26.84
4800	21.66	1.02	2.90	20.78
5000	27.66	0.71	2.41	20.89
5200	36.79	0.51	1.24	16.62
5400	54.98	0.35	11.38	94.29
5600	44.98	0.23	3.22	58.99
5800	42.27	0.13	2.13	39.43
6000	41.87	0.05	0.73	22.68
6200	42.12	0.00	6.91	7.26
6400	42.84	0.03	24.16	58.44
6600	43.84	0.04	9.94	169.84
6800	45.15	0.02	4.56	179.35
7000	48.75	0.04	1.48	173.95
7200	48.59	0.10	0.99	164.21
7400	47.96	0.19	2.64	136.14
7600	48.51	0.32	6.06	106.37
7800	49.48	0.50	6.90	173.09
8000	50.68	0.71	3.63	179.67
8200	51.93	0.95	2.22	179.77
8400	52.99	1.18	1.52	179.23
8600	53.62	1.35	1.14	178.27
8800	53.78	1.41	1.01	177.78
9000	53.34	1.35	0.95	177.79
9200	53.17	1.19	0.98	178.29
9400	53.25	0.97	1.02	179.38
9600	53.14	0.74	1.02	179.60
9800	52.93	0.54	1.04	178.07
10000	52.62	0.37	0.96	176.70



Typical Performance Data

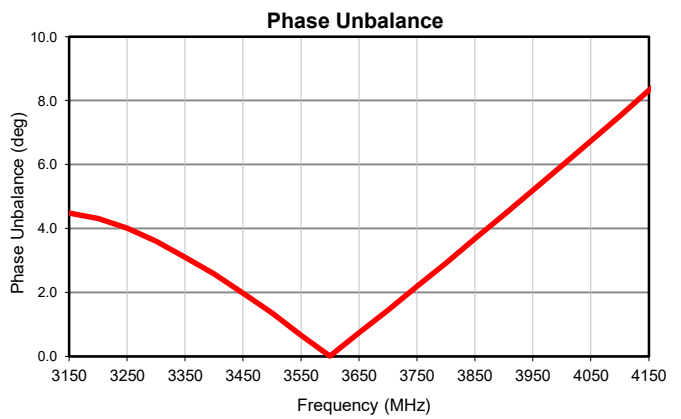
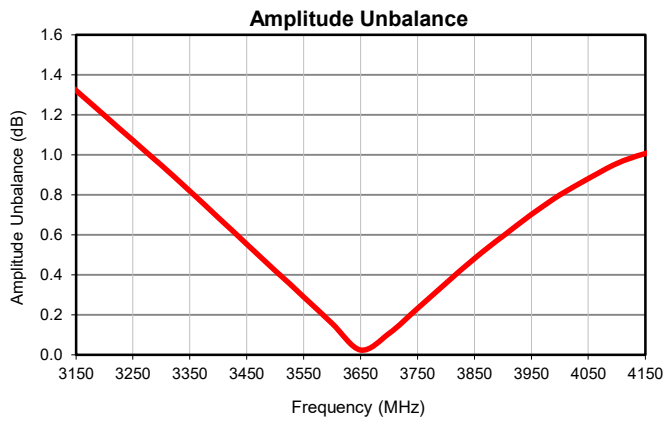
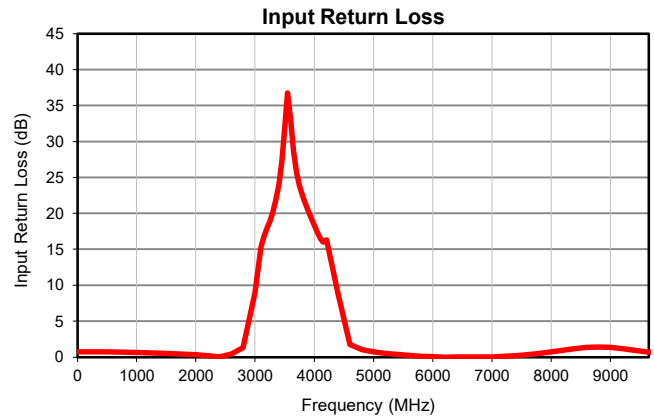
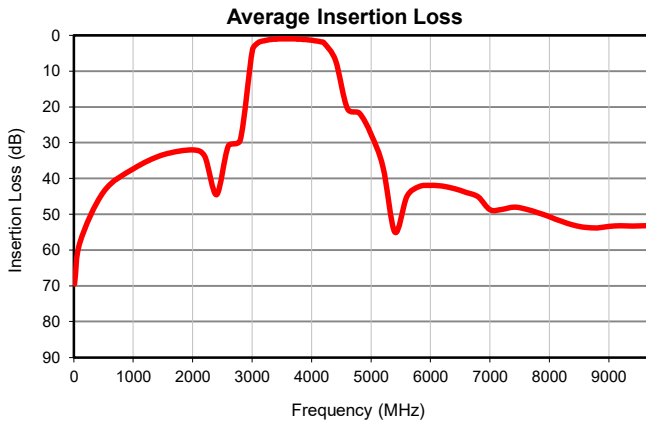

Outline Dimensions

Top View

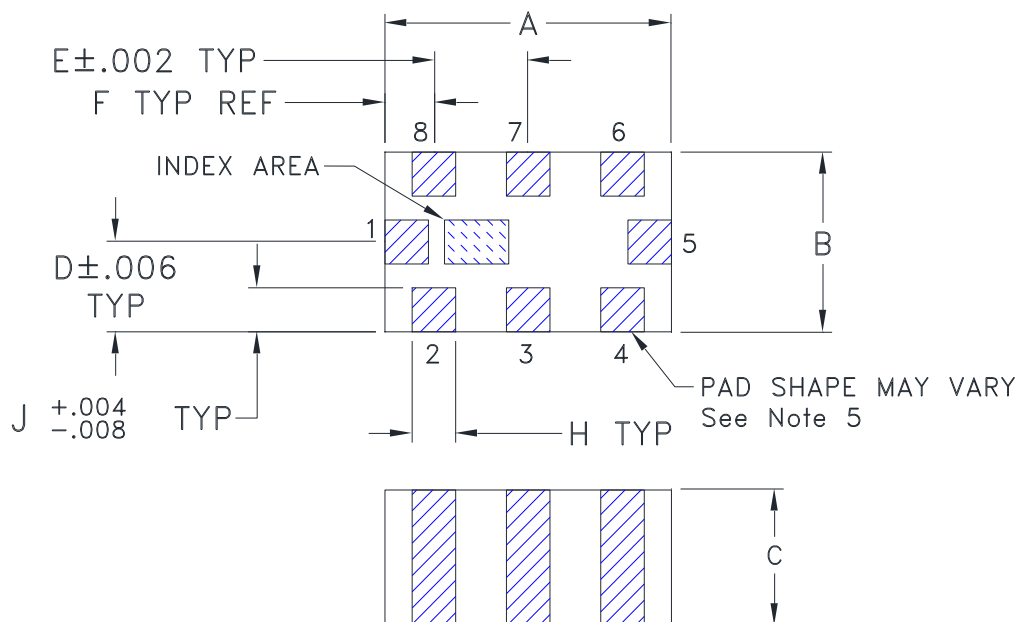

CASE#	A	B	C	D	E	F	G	H	J	WT, GRAM
GE0805C-15	.079 (2.00)	.049 (1.25)	.037 (0.95)	.025 (0.63)	.026 (0.65)	.014 (0.35)	.110 (2.80)	.012 (0.30)	.010 (0.25)	.008

Dimensions are in inches (mm). Tolerances: 2 Pl. $\pm .01(.25)$; 3 Pl. $\pm .005(.100)$

Notes:

- Open style, ceramic base
- Termination finish: For RoHS Case Styles: Tin plate over Nickel plate. All model , (+) suffix.
For RoHS-5 Case Styles: Tin-lead plate over Nickel plate. All model ,no (+) suffix.
- Pad tolerance to be non-cumulative. Minimum spacing between each pad is .004(0.1).
- Pin numbers do not appear on unit. For reference only.
- During the manufacturing process, the pad shape may not be rectangular and may take on a more semi-circle shape. However, the pad dimensions reflect this, with the pad shape being within the specified lengths. The metallization compensates accordingly and so performance will not be affected. In addition, solderability will not be influenced by the pad shape



INTERNET <http://www.minicircuits.com>

P.O. Box 350166, Brooklyn, New York 11235-0003 (718) 934-4500 Fax (718) 332-4661

Distribution Centers NORTH AMERICA 800-654-7949 • 417-335-5935 • Fax 417-335-5945 • EUROPE 44-1252-832600 • Fax 44-1252-837010

Mini-Circuits ISO 9001 & ISO 14001 Certified

**SUGGESTED MOUNTING CONFIGURATION
FOR GE0805C-15 CASE STYLE**

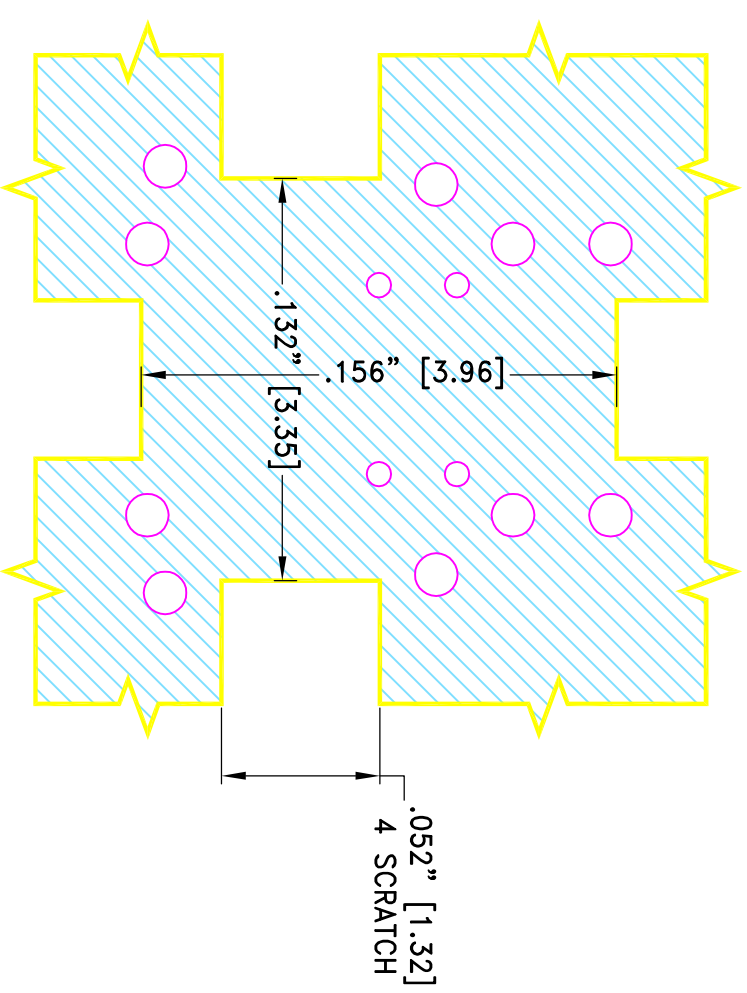
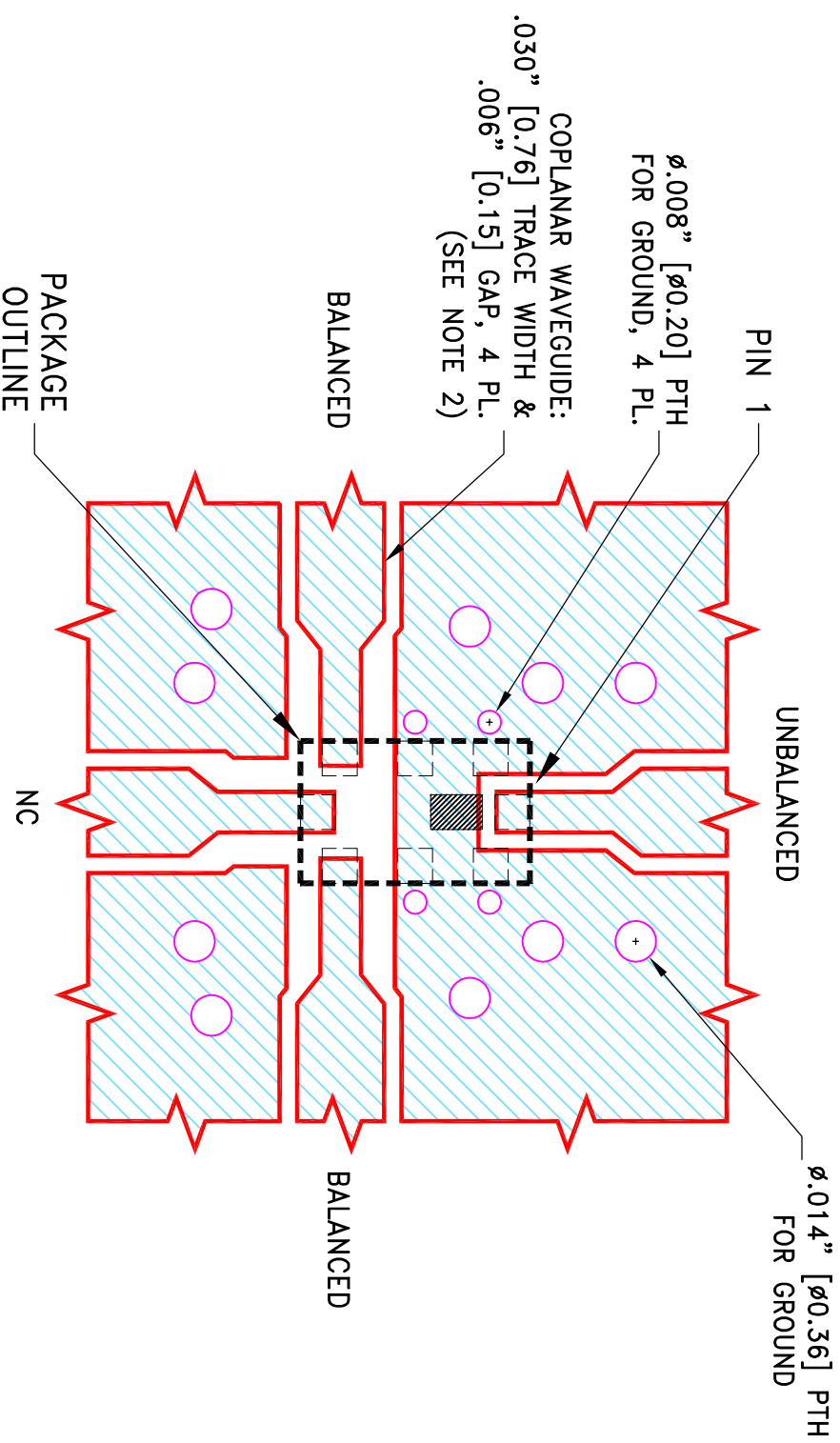

TOP VIEW TO LAYER 2

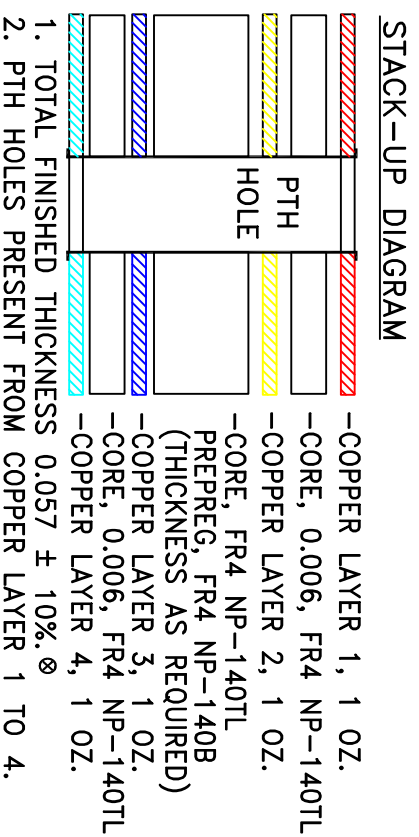

- NOTES:**
- PCB IS MULTILAYER PCB, SEE STACK-UP DIAGRAM.
 - TRACE WIDTH & GAP PARAMETERS ARE SHOWN FOR FR4 NP-140TL WITH DIELECTRIC THICKNESS .006"±.0005"; COPPER: 1 OZ. FOR OTHER MATERIALS TRACE WIDTH AND GAP MAY NEED TO BE MODIFIED.
 - COPPER LAYERS 3,4 OF THE PCB IS CONTINUOUS GROUND PLANES.
-  DENOTES COPPER LAND PATTERN FREE OF SOLDER MASK.

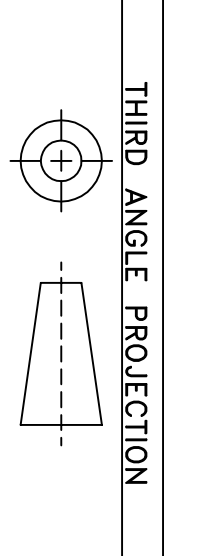

OR	ECN	NO.	DESCRIPTION	DATE	DR	AUTH
ECO-010908			NEW RELEASE	12/02/21	ITG	IL
REV	ECN	No.	DESCRIPTION	DATE	DR	AUTH

UNLESS OTHERWISE SPECIFIED		INITIALS		DATE	
DIMENSIONS ARE IN INCHES					
TOLERANCES ON:					
2 PL DECIMALS ±	.005	DRAWN	ITG	12/02/21	
3 PL DECIMALS ±		CHECKED	GF	12/02/21	
ANGLES ±	1°	APPROVED	IL	12/02/21	
FRACTIONS ±					

Mini-Circuits®
13 Neptune Avenue
Brooklyn NY 11235

PL, GE0805C-15, TB-1233+

SIZE	CODE IDENT	DRAWING NO:	REV:
B	15542	98-PL-724	OR
FILE:	98PL724	SCALE:	15:1
		SHEET:	1 OF 1

Mini-Circuits®
THIS DOCUMENT AND ITS CONTENTS ARE THE PROPERTY OF MINI-CIRCUITS. EXCEPT FOR USE EXPRESSLY GRANTED, IN WRITING, TO ITS VENDORS, VENDORS AND THE UNITED STATES GOVERNMENT, MINI-CIRCUITS RESERVES ALL PROPRIETARY DESIGN, USE, MANUFACTURING AND REPRODUCTION RIGHTS THERETO. THESE CONTENTS SHALL NOT BE USED, DUPLICATED OR DISCLOSED TO ANY OUTSIDE PARTY, IN WHOLE OR IN PART, WITHOUT WRITTEN PERMISSION OF MINI-CIRCUITS.

BSHEETA1.DWG REV:A DATE:01/12/94

Evaluation Board and Circuit

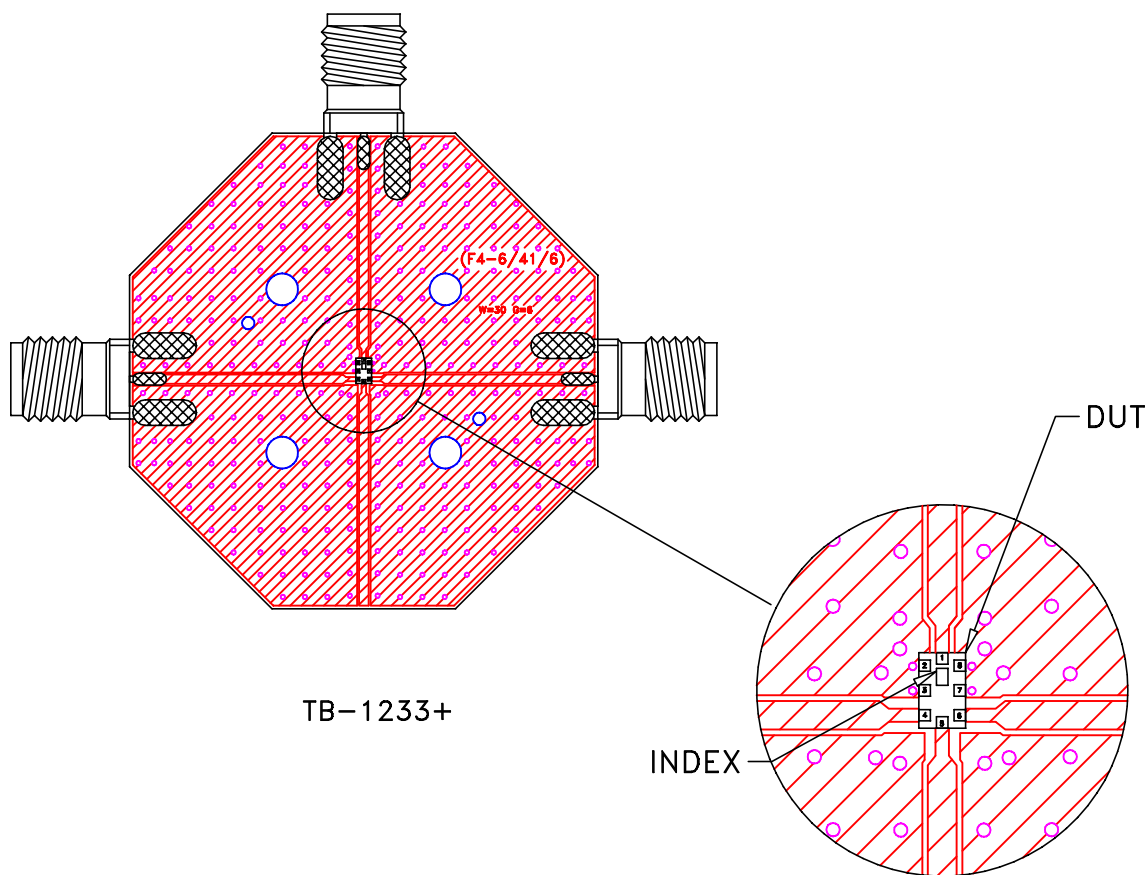

TB-1233+

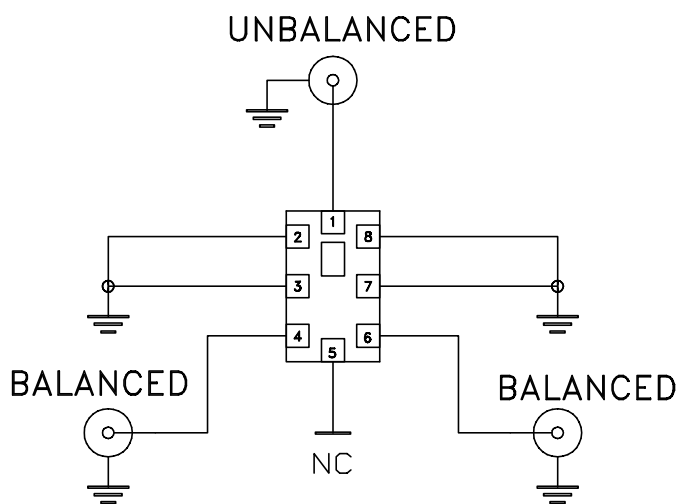

Schematic Diagram

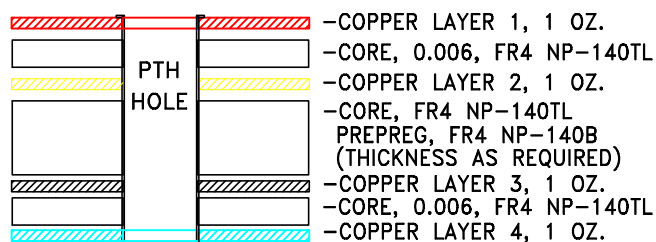

Stack-up Diagram

Notes:

1. 50 Ohm SMA Female connectors.
2. PCB Material: FR4 or equivalent, Dielectric Constant=4.5, Total finished Thickness = .057 inch.

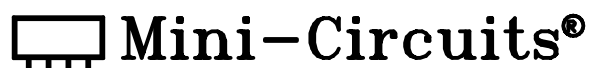



All Mini-Circuits products are manufactured under exacting quality assurance and control standards, and are capable of meeting published specifications after being subjected to any or all of the following physical and environmental test.

Specification	Test/Inspection Condition	Reference/Spec
Operating Temperature	-55° to 125° C Ambient Environment	Individual Model Data Sheet
Storage Temperature	-55° to 125° C Ambient Environment	Individual Model Data Sheet
Humidity	90 to 95% RH, 240 hours, 50°C	MIL-STD-202, Method 103, Condition A, Except 50°C and end-point electrical test done within 12 hours
Solder Reflow Heat	Sn-Pb Eutectic Process: 225°C peak Pb-Free Process: 250°C peak	J-STD-020C, Table 4-1, 4-2 and 5-2; Figure 5-1
Solderability	10X Magnification	J-STD-002, Para 4.2.5, Test S, 95% Coverage
Vibration (High Frequency)	20g peak, 10-2000 Hz, 12 times in each of three perpendicular directions (total 36)	MIL-STD-202, Method 204, Condition D
Mechanical Shock	50g, 11 ms, 1/2-sine, 18 shocks: 3 each direction, each of 3 axes	MIL-STD-202, Method 213, Condition A