

# Surface Mount Directional Coupler

## ADC-6-13+

50Ω 200 to 1300 MHz

### Maximum Ratings

|                       |                |
|-----------------------|----------------|
| Operating Temperature | -40°C to 85°C  |
| Storage Temperature   | -55°C to 100°C |

Permanent damage may occur if any of these limits are exceeded.

### Pin Connections

|                         |   |
|-------------------------|---|
| INPUT                   | 1 |
| OUTPUT                  | 6 |
| COUPLED                 | 3 |
| GROUND                  | 2 |
| 50Ω TERM EXTERNAL       | 4 |
| GROUND or NO CONNECTION | 5 |

### Outline Drawing

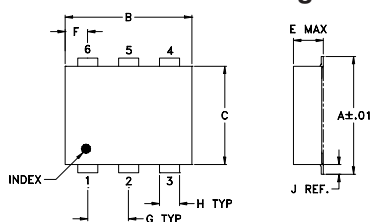

### PCB Land Pattern

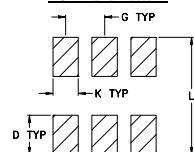

Suggested Layout,  
Tolerance to be within ±.002

### Outline Dimensions (inch/mm)

|      |      |      |      |      |       |      |
|------|------|------|------|------|-------|------|
| A    | B    | C    | D    | E    | F     | G    |
| .272 | .310 | .220 | .100 | .112 | .055  | .100 |
| 6.91 | 7.87 | 5.59 | 2.54 | 2.84 | 1.40  | 2.54 |
| H    | J    | K    | L    |      | wt    |      |
| .030 | .026 | .065 | .300 |      | grams |      |
| 0.76 | 0.66 | 1.65 | 7.62 |      | 0.20  |      |

### Demo Board MCL P/N: TB-05 Suggested PCB Layout (PL-041)

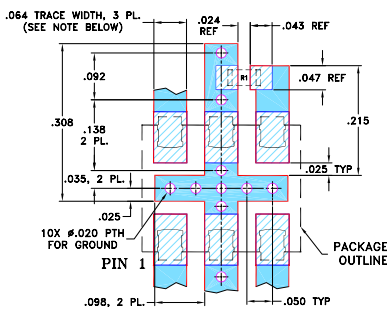

RESISTOR R1: 49.9 Ohm, 0603 SIZE.

- NOTES:
- TRACE WIDTH IS SHOWN FOR ROGERS RO4350B WITH DIELECTRIC THICKNESS .030" ± .002"; COPPER: 1/2 OZ. EACH SIDE. FOR OTHER MATERIALS TRACE WIDTH MAY NEED TO BE MODIFIED.
  - BOTTOM SIDE OF THE PCB IS CONTINUOUS GROUND PLANE.
  - DENOTES PCB COPPER LAYOUT WITH SMOBC (SOLDER MASK OVER BARE COPPER)
  - DENOTES COPPER LAND PATTERN FREE OF SOLDER MASK

### Notes

- A. Performance and quality attributes and conditions not expressly stated in this specification document are intended to be excluded and do not form a part of this specification document.  
 B. Electrical specifications and performance data contained in this specification document are based on Mini-Circuit's applicable established test performance criteria and measurement instructions.  
 C. The parts covered by this specification document are subject to Mini-Circuit's standard limited warranty and terms and conditions (collectively, "Standard Terms"); Purchasers of this part are entitled to the rights and benefits contained therein. For a full statement of the Standard Terms and the exclusive rights and remedies thereunder, please visit Mini-Circuit's website at [www.minicircuits.com/MCLStore/terms.jsp](http://www.minicircuits.com/MCLStore/terms.jsp)

### Features

- wideband, 200-1300 MHz
- excellent VSWR: 1.3:1 typ.
- excellent coupling flatness, ±0.5 typ.
- aqueous washable
- protected by U.S. Patents 6,133,525 & 6,140,887

### Applications

- cellular
- VHF/UHF receivers

Generic photo used for illustration purposes only  
CASE STYLE: CD542

### +RoHS Compliant

The +Suffix identifies RoHS Compliance. See our web site for RoHS Compliance methodologies and qualifications

Available Tape and Reel at no extra cost

| Reel Size | Devices/Reel     |
|-----------|------------------|
| 7"        | 20, 50, 100, 200 |
| 13"       | 500, 1000        |

### Directional Coupler Electrical Specifications

| FREQ.<br>(MHz)                 | COUPLING<br>(dB) |          | MAINLINE LOSS <sup>1</sup><br>(dB) |      | DIRECTIVITY<br>(dB) |      | VSWR<br>(:1) | POWER<br>INPUT, W |           |
|--------------------------------|------------------|----------|------------------------------------|------|---------------------|------|--------------|-------------------|-----------|
|                                | Nom.             | Flatness | Typ.                               | Max. | Typ.                | Min. |              | Typ.              | L<br>Max. |
| f <sub>c</sub> -f <sub>u</sub> |                  |          |                                    |      |                     |      |              |                   |           |
| 200-1300                       | 6.2±0.5          | ±0.9     | 1.8                                | 2.5  | 17                  | 10   | 1.3          | 0.5               | 0.5       |

1. Mainline loss includes theoretical power loss at coupled port.

### Typical Performance Data

| Frequency<br>(MHz) | Mainline Loss<br>(dB)<br>In-Out | Coupling<br>(dB)<br>In-Cpl | Directivity<br>(dB) | Return Loss<br>(dB) |       |       |
|--------------------|---------------------------------|----------------------------|---------------------|---------------------|-------|-------|
|                    |                                 |                            |                     | In                  | Out   | Cpl   |
| 200.00             | 1.63                            | 6.78                       | 15.32               | 16.16               | 16.80 | 16.37 |
| 400.00             | 1.57                            | 6.77                       | 16.43               | 19.27               | 20.03 | 18.22 |
| 500.00             | 1.56                            | 6.70                       | 16.81               | 20.80               | 20.81 | 18.74 |
| 600.00             | 1.59                            | 6.61                       | 17.19               | 22.02               | 21.37 | 18.95 |
| 700.00             | 1.64                            | 6.52                       | 17.56               | 22.08               | 21.46 | 19.14 |
| 900.00             | 1.76                            | 6.29                       | 18.16               | 20.57               | 20.96 | 20.03 |
| 1000.00            | 1.85                            | 6.20                       | 18.24               | 19.80               | 21.45 | 20.54 |
| 1100.00            | 1.95                            | 6.11                       | 18.05               | 18.83               | 19.86 | 21.08 |
| 1200.00            | 2.05                            | 6.04                       | 17.55               | 17.57               | 19.28 | 21.80 |
| 1300.00            | 2.16                            | 5.98                       | 16.79               | 16.32               | 18.80 | 22.81 |

### ADC-6-13+ MAINLINE LOSS

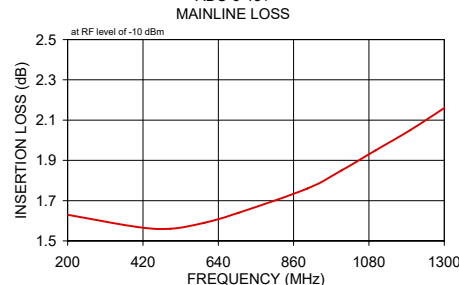

### ADC-6-13+ COUPLING & DIRECTIVITY

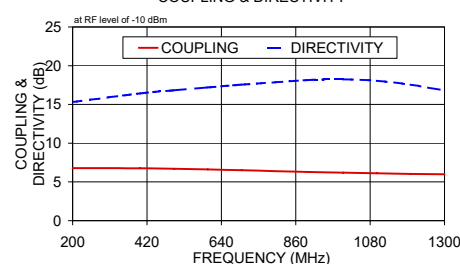

### ADC-6-13+ RETURN LOSS

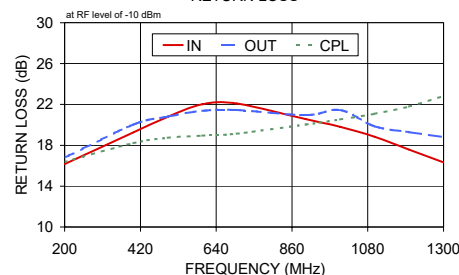

### Electrical Schematic

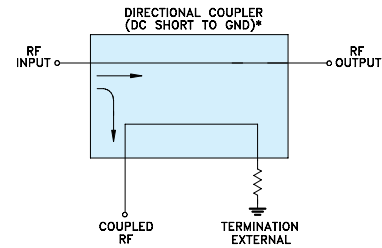

\* ELECTRICAL SCHEMATIC IS FOR DIRECTIONAL COUPLER WITH INTERNAL TRANSFORMER(S) AND EXTERNAL TERMINATION.



# Directional Coupler

# ADC-6-13+

## Typical Performance Data

TEST CONDITIONS: INPUT POWER =0 dBm @Temperature = +25°C

| FREQUENCY<br>(MHz) | INSERTION<br>LOSS<br>(dB) | COUPLING<br>LOSS<br>(dB) | DIRECTIVITY<br>(dB) | RETURN LOSS<br>(dB) |       |       |
|--------------------|---------------------------|--------------------------|---------------------|---------------------|-------|-------|
|                    |                           |                          |                     | IN                  | OUT   | CPL   |
| 10                 | 8.00                      | 9.27                     | 6.79                | 1.77                | 1.06  | 1.82  |
| 25                 | 3.84                      | 6.60                     | 8.01                | 5.50                | 3.63  | 5.65  |
| 50                 | 2.35                      | 6.48                     | 10.37               | 9.71                | 7.46  | 9.89  |
| 75                 | 1.95                      | 6.59                     | 12.05               | 12.31               | 10.33 | 12.45 |
| 100                | 1.80                      | 6.66                     | 13.09               | 14.03               | 12.45 | 14.11 |
| 125                | 1.72                      | 6.69                     | 13.74               | 15.24               | 14.09 | 15.28 |
| 150                | 1.67                      | 6.72                     | 14.17               | 16.20               | 15.42 | 16.17 |
| 175                | 1.64                      | 6.73                     | 14.45               | 16.96               | 16.53 | 16.88 |
| 200                | 1.62                      | 6.74                     | 14.64               | 17.61               | 17.48 | 17.48 |
| 225                | 1.61                      | 6.74                     | 14.78               | 18.15               | 18.30 | 17.99 |
| 250                | 1.60                      | 6.74                     | 14.88               | 18.64               | 19.03 | 18.45 |
| 275                | 1.59                      | 6.75                     | 14.93               | 19.08               | 19.69 | 18.87 |
| 300                | 1.58                      | 6.73                     | 14.97               | 19.47               | 20.28 | 19.27 |
| 350                | 1.58                      | 6.71                     | 15.01               | 20.15               | 21.35 | 19.98 |
| 400                | 1.58                      | 6.68                     | 15.01               | 20.76               | 22.35 | 20.67 |
| 450                | 1.59                      | 6.64                     | 14.99               | 21.25               | 23.26 | 21.29 |
| 500                | 1.60                      | 6.60                     | 15.01               | 21.62               | 24.25 | 21.88 |
| 550                | 1.62                      | 6.55                     | 15.00               | 21.95               | 25.28 | 22.47 |
| 600                | 1.65                      | 6.50                     | 15.00               | 22.21               | 26.45 | 23.06 |
| 650                | 1.68                      | 6.45                     | 15.01               | 22.49               | 27.68 | 23.69 |
| 700                | 1.71                      | 6.39                     | 15.08               | 22.70               | 29.29 | 24.34 |
| 750                | 1.74                      | 6.33                     | 15.24               | 23.03               | 31.29 | 25.09 |
| 800                | 1.77                      | 6.27                     | 15.36               | 23.37               | 33.78 | 26.00 |
| 850                | 1.80                      | 6.21                     | 15.52               | 23.82               | 37.93 | 27.09 |
| 900                | 1.84                      | 6.15                     | 15.76               | 24.42               | 45.03 | 28.48 |
| 950                | 1.87                      | 6.09                     | 16.10               | 25.18               | 47.44 | 30.23 |
| 1000               | 1.90                      | 6.05                     | 16.51               | 26.19               | 38.38 | 32.36 |
| 1050               | 1.94                      | 6.01                     | 17.09               | 27.24               | 33.54 | 34.26 |
| 1100               | 1.98                      | 5.97                     | 17.65               | 28.53               | 30.52 | 32.83 |
| 1150               | 2.01                      | 5.94                     | 18.54               | 28.98               | 27.92 | 29.58 |
| 1200               | 2.04                      | 5.93                     | 19.62               | 27.66               | 25.85 | 26.12 |
| 1250               | 2.08                      | 5.94                     | 21.05               | 25.35               | 24.12 | 23.15 |
| 1300               | 2.12                      | 5.98                     | 22.87               | 22.71               | 22.53 | 20.60 |
| 1350               | 2.16                      | 6.03                     | 24.85               | 20.10               | 21.13 | 18.34 |
| 1400               | 2.21                      | 6.15                     | 25.95               | 17.85               | 19.89 | 16.28 |
| 1450               | 2.27                      | 6.30                     | 24.08               | 15.72               | 18.72 | 14.46 |
| 1500               | 2.35                      | 6.51                     | 20.59               | 13.85               | 17.64 | 12.81 |
| 1600               | 2.58                      | 7.18                     | 14.42               | 10.65               | 15.73 | 9.95  |
| 1700               | 2.96                      | 8.32                     | 9.36                | 8.14                | 14.20 | 7.65  |
| 1800               | 3.50                      | 10.06                    | 4.84                | 6.25                | 13.01 | 5.91  |
| 1900               | 4.16                      | 12.49                    | 0.48                | 4.97                | 12.09 | 4.74  |
| 2000               | 4.82                      | 15.63                    | 4.04                | 4.22                | 11.43 | 4.08  |
| 2100               | 5.35                      | 18.09                    | 7.35                | 3.94                | 10.76 | 3.88  |
| 2200               | 5.59                      | 17.49                    | 7.19                | 4.03                | 10.03 | 4.06  |
| 2300               | 5.57                      | 14.38                    | 3.90                | 4.50                | 9.24  | 4.62  |
| 2400               | 5.63                      | 11.27                    | 0.89                | 4.98                | 8.68  | 5.17  |
| 2500               | 6.36                      | 9.21                     | 7.73                | 4.65                | 9.10  | 4.67  |
| 2600               | 7.80                      | 8.55                     | 13.24               | 3.89                | 10.41 | 3.73  |
| 2700               | 9.02                      | 8.57                     | 8.09                | 3.48                | 11.70 | 3.24  |
| 2800               | 9.72                      | 8.88                     | 4.53                | 3.45                | 12.41 | 3.19  |
| 2900               | 9.87                      | 9.03                     | 2.47                | 3.59                | 12.37 | 3.28  |
| 3000               | 9.79                      | 9.47                     | 0.74                | 3.84                | 11.82 | 3.46  |

REV. X1  
ADC-6-13+  
081007  
Page 1 of 3



IF/RF MICROWAVE COMPONENTS • ISO 9001 ISO 14001 AS 9100 CERTIFIED • RoHS compliant  
P.O. Box 350166, Brooklyn, New York 11235-0003 (718) 934-4500 Fax (718) 332-4661



The Design Engineers Search Engine finds the model you need, Instantly • For detailed performance specs & shopping online see



# Directional Coupler

# ADC-6-13+

## Typical Performance Data

TEST CONDITIONS: INPUT POWER =0 dBm @Temperature = -40°C

| FREQUENCY<br>(MHz) | INSERTION<br>LOSS<br>(dB) | COUPLING<br>LOSS<br>(dB) | DIRECTIVITY<br>(dB) | RETURN LOSS<br>(dB) |       |       |
|--------------------|---------------------------|--------------------------|---------------------|---------------------|-------|-------|
|                    |                           |                          |                     | IN                  | OUT   | CPL   |
| 10                 | 8.08                      | 9.36                     | 6.78                | 1.74                | 1.05  | 1.78  |
| 25                 | 3.91                      | 6.66                     | 7.98                | 5.44                | 3.62  | 5.56  |
| 50                 | 2.39                      | 6.50                     | 10.31               | 9.60                | 7.41  | 9.70  |
| 75                 | 1.98                      | 6.61                     | 12.02               | 12.08               | 10.18 | 12.23 |
| 100                | 1.82                      | 6.67                     | 13.08               | 13.67               | 12.16 | 13.91 |
| 125                | 1.73                      | 6.70                     | 13.69               | 14.84               | 13.75 | 15.12 |
| 150                | 1.67                      | 6.72                     | 14.11               | 15.84               | 15.16 | 16.03 |
| 175                | 1.63                      | 6.72                     | 14.45               | 16.66               | 16.33 | 16.73 |
| 200                | 1.60                      | 6.73                     | 14.69               | 17.28               | 17.23 | 17.30 |
| 225                | 1.58                      | 6.73                     | 14.87               | 17.76               | 17.93 | 17.79 |
| 250                | 1.57                      | 6.73                     | 14.95               | 18.18               | 18.57 | 18.24 |
| 275                | 1.56                      | 6.73                     | 14.99               | 18.65               | 19.26 | 18.65 |
| 300                | 1.54                      | 6.71                     | 15.04               | 19.11               | 19.91 | 19.03 |
| 350                | 1.53                      | 6.69                     | 15.12               | 19.76               | 20.86 | 19.76 |
| 400                | 1.53                      | 6.66                     | 15.06               | 20.29               | 21.72 | 20.52 |
| 450                | 1.53                      | 6.62                     | 15.04               | 20.92               | 22.72 | 21.21 |
| 500                | 1.53                      | 6.57                     | 15.09               | 21.49               | 23.58 | 21.86 |
| 550                | 1.54                      | 6.53                     | 15.06               | 21.95               | 24.53 | 22.52 |
| 600                | 1.56                      | 6.47                     | 15.06               | 22.34               | 25.60 | 23.18 |
| 650                | 1.58                      | 6.41                     | 15.05               | 22.70               | 26.66 | 23.95 |
| 700                | 1.61                      | 6.35                     | 15.11               | 23.03               | 28.20 | 24.74 |
| 750                | 1.63                      | 6.29                     | 15.24               | 23.49               | 29.90 | 25.67 |
| 800                | 1.66                      | 6.23                     | 15.36               | 24.03               | 32.07 | 26.79 |
| 850                | 1.68                      | 6.16                     | 15.58               | 24.82               | 34.92 | 28.19 |
| 900                | 1.71                      | 6.10                     | 15.81               | 25.56               | 37.11 | 30.03 |
| 950                | 1.74                      | 6.04                     | 16.05               | 26.27               | 40.35 | 32.27 |
| 1000               | 1.76                      | 6.00                     | 16.42               | 27.42               | 38.30 | 35.31 |
| 1050               | 1.80                      | 5.95                     | 16.93               | 28.69               | 34.03 | 37.44 |
| 1100               | 1.83                      | 5.91                     | 17.50               | 30.24               | 30.55 | 34.15 |
| 1150               | 1.85                      | 5.87                     | 18.43               | 30.84               | 27.88 | 29.73 |
| 1200               | 1.88                      | 5.86                     | 19.40               | 29.11               | 26.02 | 26.05 |
| 1250               | 1.91                      | 5.86                     | 20.60               | 25.88               | 24.07 | 23.22 |
| 1300               | 1.95                      | 5.89                     | 22.29               | 22.45               | 22.01 | 20.71 |
| 1350               | 1.98                      | 5.94                     | 24.52               | 19.65               | 20.44 | 18.36 |
| 1400               | 2.03                      | 6.05                     | 26.16               | 17.48               | 19.27 | 16.27 |
| 1450               | 2.09                      | 6.18                     | 24.90               | 15.46               | 18.17 | 14.41 |
| 1500               | 2.15                      | 6.38                     | 21.42               | 13.69               | 17.11 | 12.77 |
| 1600               | 2.37                      | 7.02                     | 15.01               | 10.58               | 15.29 | 9.90  |
| 1700               | 2.73                      | 8.11                     | 9.81                | 8.03                | 13.73 | 7.58  |
| 1800               | 3.28                      | 9.83                     | 5.14                | 6.01                | 12.43 | 5.78  |
| 1900               | 3.92                      | 12.21                    | 0.80                | 4.73                | 11.56 | 4.56  |
| 2000               | 4.65                      | 15.47                    | 3.94                | 3.86                | 10.75 | 3.85  |
| 2100               | 5.20                      | 18.28                    | 7.61                | 3.52                | 10.09 | 3.56  |
| 2200               | 5.47                      | 18.02                    | 7.88                | 3.54                | 9.39  | 3.64  |
| 2300               | 5.49                      | 14.97                    | 4.85                | 3.90                | 8.55  | 4.08  |
| 2400               | 5.44                      | 11.68                    | 0.41                | 4.44                | 7.76  | 4.67  |
| 2500               | 6.02                      | 9.36                     | 5.84                | 4.24                | 7.82  | 4.46  |
| 2600               | 7.45                      | 8.41                     | 14.48               | 3.54                | 9.04  | 3.53  |
| 2700               | 8.84                      | 8.30                     | 10.24               | 3.07                | 10.49 | 2.97  |
| 2800               | 9.75                      | 8.57                     | 5.78                | 2.95                | 11.47 | 2.87  |
| 2900               | 10.03                     | 8.63                     | 3.48                | 3.08                | 11.87 | 2.94  |
| 3000               | 9.98                      | 8.99                     | 1.60                | 3.24                | 11.57 | 3.11  |

REV. X1  
ADC-6-13+  
081007  
Page 2 of 3



IF/RF MICROWAVE COMPONENTS • ISO 9001 ISO 14001 AS 9100 CERTIFIED • RoHS compliant  
P.O. Box 350166, Brooklyn, New York 11235-0003 (718) 934-4500 Fax (718) 332-4661



The Design Engineers Search Engine finds the model you need, Instantly • For detailed performance specs & shopping online see



# Directional Coupler

# ADC-6-13+

## Typical Performance Data

TEST CONDITIONS: INPUT POWER =0 dBm @Temperature = +85°C

| FREQUENCY<br>(MHz) | INSERTION<br>LOSS<br>(dB) | COUPLING<br>LOSS<br>(dB) | DIRECTIVITY<br>(dB) | RETURN LOSS<br>(dB) |       |       |
|--------------------|---------------------------|--------------------------|---------------------|---------------------|-------|-------|
|                    |                           |                          |                     | IN                  | OUT   | CPL   |
| 10                 | 7.90                      | 9.20                     | 6.80                | 1.81                | 1.09  | 1.86  |
| 25                 | 3.78                      | 6.59                     | 8.05                | 5.57                | 3.67  | 5.74  |
| 50                 | 2.32                      | 6.50                     | 10.42               | 9.81                | 7.54  | 10.05 |
| 75                 | 1.93                      | 6.62                     | 12.04               | 12.48               | 10.49 | 12.60 |
| 100                | 1.78                      | 6.68                     | 13.10               | 14.30               | 12.69 | 14.24 |
| 125                | 1.71                      | 6.72                     | 13.78               | 15.52               | 14.33 | 15.38 |
| 150                | 1.67                      | 6.75                     | 14.21               | 16.42               | 15.61 | 16.26 |
| 175                | 1.64                      | 6.76                     | 14.46               | 17.15               | 16.67 | 16.99 |
| 200                | 1.62                      | 6.77                     | 14.62               | 17.84               | 17.70 | 17.62 |
| 225                | 1.61                      | 6.78                     | 14.76               | 18.45               | 18.64 | 18.15 |
| 250                | 1.60                      | 6.78                     | 14.87               | 18.95               | 19.38 | 18.62 |
| 275                | 1.60                      | 6.79                     | 14.95               | 19.34               | 20.01 | 19.06 |
| 300                | 1.60                      | 6.77                     | 14.99               | 19.69               | 20.51 | 19.48 |
| 350                | 1.60                      | 6.76                     | 14.99               | 20.34               | 21.69 | 20.20 |
| 400                | 1.60                      | 6.73                     | 15.02               | 20.91               | 22.74 | 20.84 |
| 450                | 1.62                      | 6.70                     | 15.02               | 21.28               | 23.59 | 21.41 |
| 500                | 1.64                      | 6.66                     | 15.04               | 21.62               | 24.59 | 21.95 |
| 550                | 1.67                      | 6.62                     | 15.04               | 21.85               | 25.63 | 22.48 |
| 600                | 1.69                      | 6.56                     | 15.06               | 22.00               | 26.74 | 23.05 |
| 650                | 1.73                      | 6.51                     | 15.07               | 22.21               | 28.03 | 23.67 |
| 700                | 1.76                      | 6.46                     | 15.17               | 22.41               | 29.72 | 24.28 |
| 750                | 1.80                      | 6.40                     | 15.34               | 22.71               | 31.75 | 25.06 |
| 800                | 1.84                      | 6.34                     | 15.47               | 23.12               | 34.55 | 25.89 |
| 850                | 1.87                      | 6.28                     | 15.67               | 23.56               | 39.54 | 26.93 |
| 900                | 1.91                      | 6.23                     | 15.95               | 24.17               | 49.30 | 28.27 |
| 950                | 1.95                      | 6.17                     | 16.32               | 24.87               | 48.37 | 29.98 |
| 1000               | 1.99                      | 6.14                     | 16.72               | 25.91               | 39.45 | 31.90 |
| 1050               | 2.02                      | 6.10                     | 17.34               | 27.10               | 34.77 | 33.45 |
| 1100               | 2.06                      | 6.06                     | 17.99               | 28.68               | 31.62 | 32.09 |
| 1150               | 2.10                      | 6.03                     | 18.92               | 29.73               | 29.04 | 28.90 |
| 1200               | 2.14                      | 6.03                     | 20.06               | 28.36               | 26.73 | 25.68 |
| 1250               | 2.18                      | 6.05                     | 21.61               | 25.77               | 24.82 | 22.87 |
| 1300               | 2.22                      | 6.08                     | 23.60               | 22.95               | 23.26 | 20.37 |
| 1350               | 2.27                      | 6.15                     | 25.74               | 20.29               | 21.81 | 18.20 |
| 1400               | 2.32                      | 6.26                     | 26.49               | 18.00               | 20.52 | 16.22 |
| 1450               | 2.39                      | 6.42                     | 23.94               | 15.89               | 19.36 | 14.48 |
| 1500               | 2.47                      | 6.65                     | 20.24               | 14.01               | 18.25 | 12.86 |
| 1600               | 2.72                      | 7.35                     | 14.11               | 10.83               | 16.28 | 10.04 |
| 1700               | 3.11                      | 8.52                     | 9.10                | 8.32                | 14.69 | 7.79  |
| 1800               | 3.64                      | 10.26                    | 4.66                | 6.48                | 13.48 | 6.08  |
| 1900               | 4.32                      | 12.71                    | 0.32                | 5.20                | 12.44 | 4.94  |
| 2000               | 4.97                      | 15.87                    | 4.19                | 4.48                | 11.72 | 4.31  |
| 2100               | 5.48                      | 18.20                    | 7.35                | 4.23                | 11.12 | 4.13  |
| 2200               | 5.71                      | 17.31                    | 6.84                | 4.39                | 10.39 | 4.36  |
| 2300               | 5.71                      | 14.17                    | 3.36                | 4.90                | 9.70  | 4.95  |
| 2400               | 5.86                      | 11.18                    | 1.59                | 5.31                | 9.32  | 5.40  |
| 2500               | 6.69                      | 9.36                     | 8.52                | 4.88                | 10.02 | 4.74  |
| 2600               | 8.10                      | 8.82                     | 11.65               | 4.11                | 11.43 | 3.84  |
| 2700               | 9.18                      | 8.92                     | 6.98                | 3.75                | 12.62 | 3.40  |
| 2800               | 9.78                      | 9.27                     | 3.83                | 3.77                | 13.10 | 3.37  |
| 2900               | 9.97                      | 9.49                     | 1.81                | 3.87                | 12.65 | 3.47  |
| 3000               | 9.87                      | 9.92                     | 0.19                | 4.14                | 11.88 | 3.68  |

REV. X1  
ADC-6-13+  
081007  
Page 3 of 3



IF/RF MICROWAVE COMPONENTS • ISO 9001 ISO 14001 AS 9100 CERTIFIED • RoHS compliant  
P.O. Box 350166, Brooklyn, New York 11235-0003 (718) 934-4500 Fax (718) 332-4661



The Design Engineers Search Engine finds the model you need, Instantly • For detailed performance specs & shopping online see



## Typical Performance Curves

### Insertion Loss

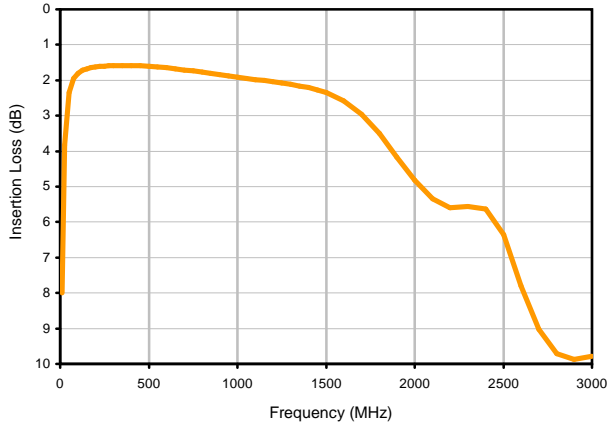

### Insertion Loss vs. TEMPERATURE

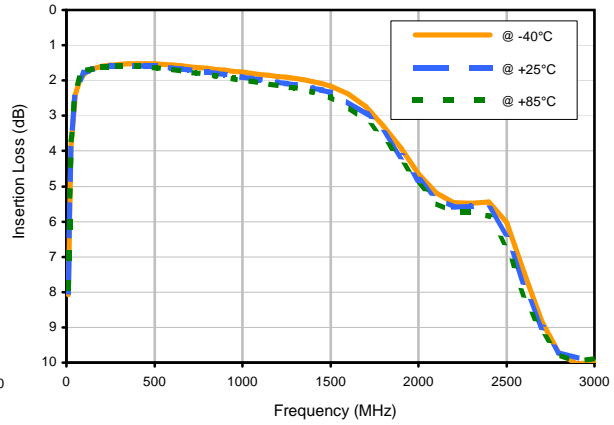

### Coupling Loss vs. TEMPERATURE

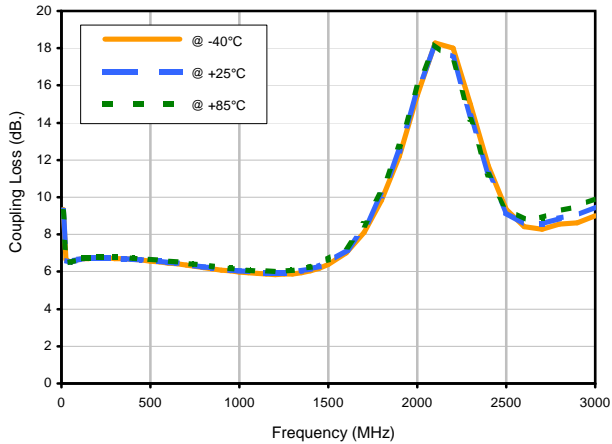

### Directivity vs. TEMPERATURE

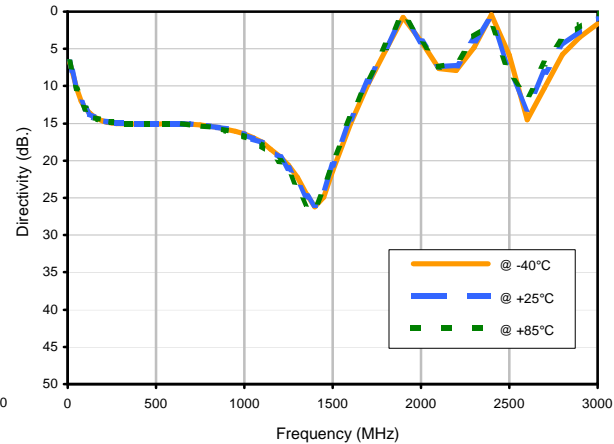

## Typical Performance Curves

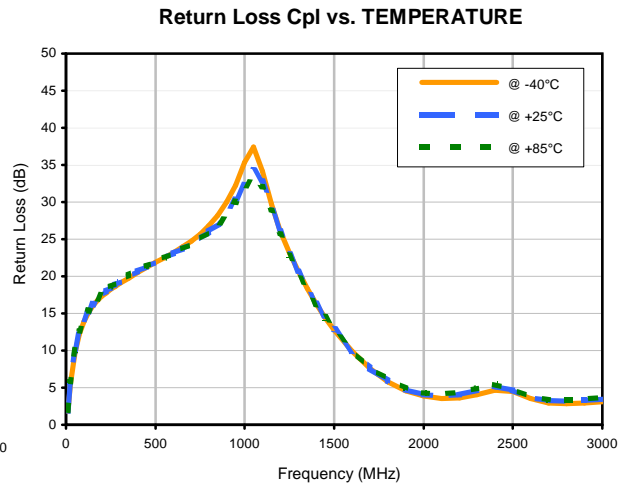
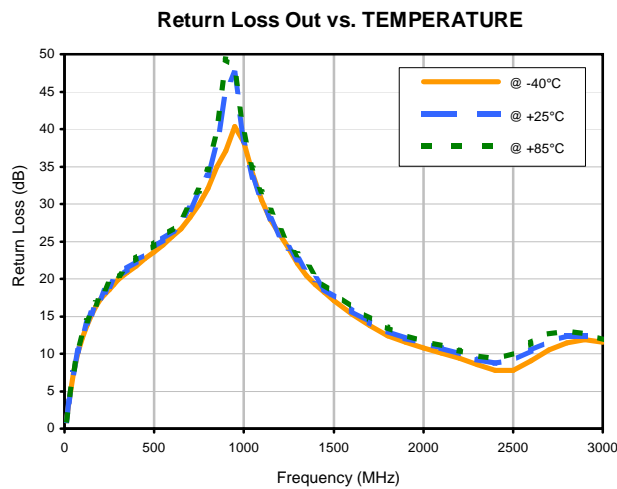
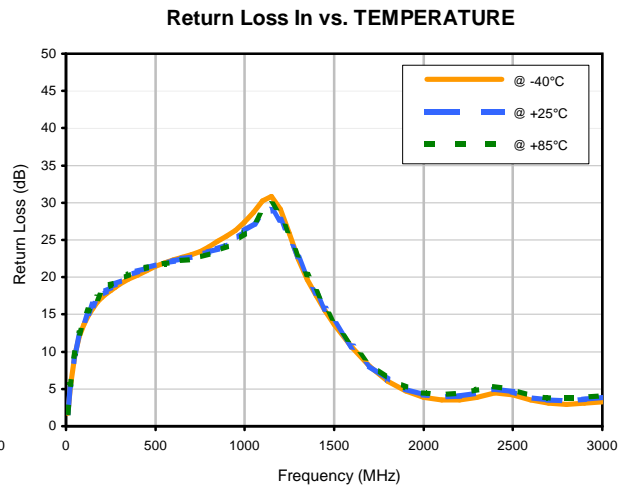
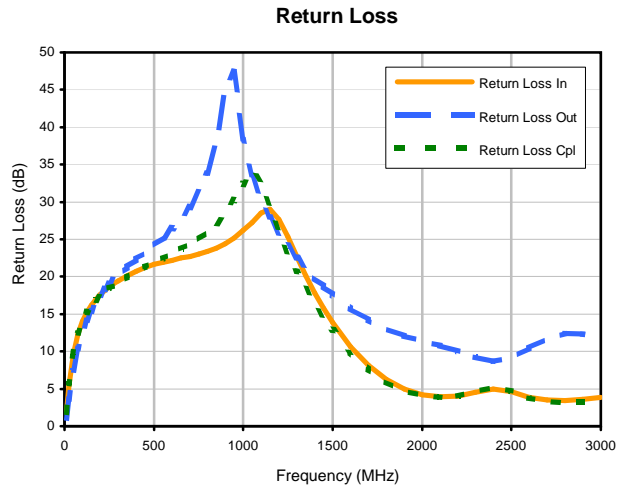

# Case Style

# CD

CD541  
CD542  
CD636  
CD637

## Outline Dimensions

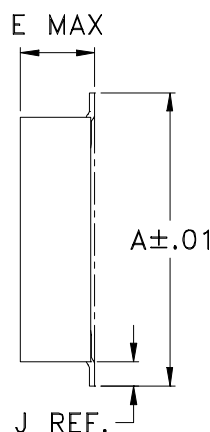
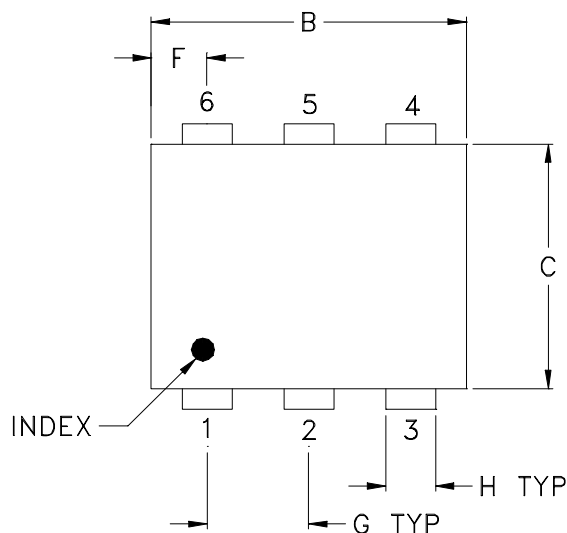

## PCB Land Pattern

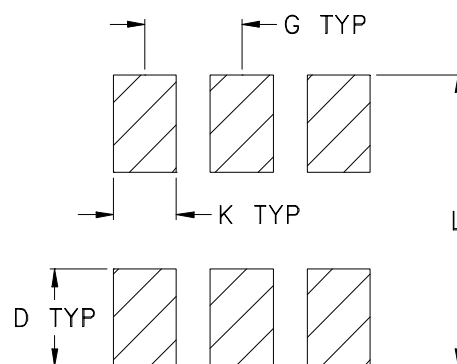

Suggested Layout,  
Tolerance to be within  $\pm .002$

| CASE# | A              | B              | C              | D              | E              | F              | G              | H              | J              | K              | L              | WT, GRAM |
|-------|----------------|----------------|----------------|----------------|----------------|----------------|----------------|----------------|----------------|----------------|----------------|----------|
| CD541 |                |                |                |                | .082<br>(2.08) |                |                |                |                |                |                | .15      |
| CD542 | .272<br>(6.91) | .310<br>(7.87) | .220<br>(5.58) | .100<br>(2.54) | .112<br>(2.84) | .055<br>(1.40) | .100<br>(2.54) | .030<br>(0.76) | .026<br>(0.66) | .065<br>(1.65) | .300<br>(7.62) | .20      |
| CD636 |                |                |                |                | .162<br>(4.11) |                |                |                |                |                |                | .25      |
| CD637 |                |                |                |                | .206<br>(5.23) |                |                |                |                |                |                | .40      |

Dimensions are in inches (mm). Tolerances: 2 Pl.  $\pm .01$ ; 3 Pl.  $\pm .005$

### Notes:

- Case material: Plastic.
- Termination finish:
  - For RoHS Case Styles: Tin plate over Nickel plate. All models, (+) suffix.
  - For RoHS-5 Case Styles: Tin-Lead plate. All models, no (+) suffix.

**Mini-Circuits**

INTERNET <http://www.minicircuits.com>

P.O. Box 350166, Brooklyn, New York 11235-0003 (718) 934-4500 Fax (718) 332-4661

Distribution Centers NORTH AMERICA 800-654-7949 • 417-335-5935 • Fax 417-335-5945 • EUROPE 44-1252-832600 • Fax 44-1252-837010

Mini-Circuits ISO 9001 & ISO 14001 Certified

# Tape & Reel Packaging TR-F34

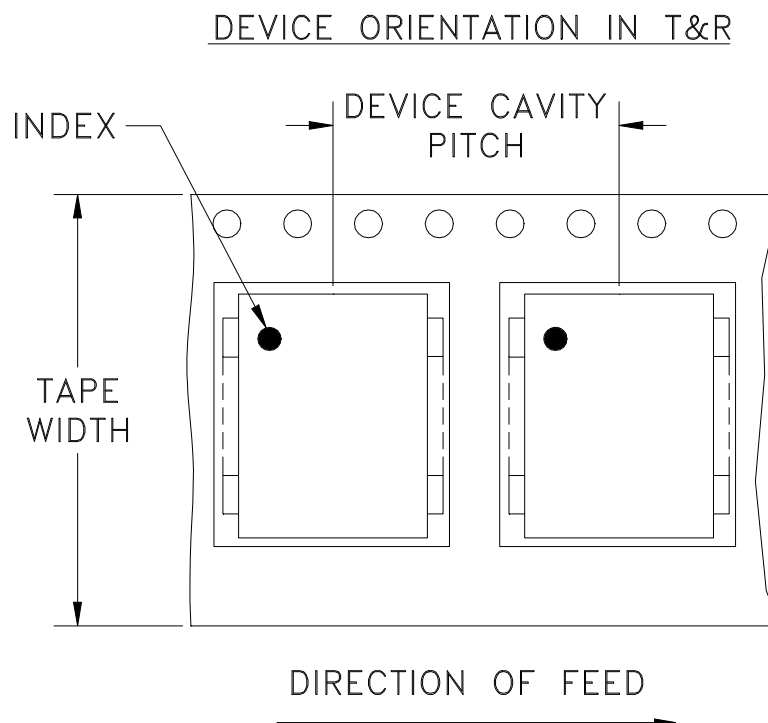

| Tape Width, mm | Device Cavity Pitch, mm | Reel Size, inches | Devices per Reel see note          |     |
|----------------|-------------------------|-------------------|------------------------------------|-----|
| 16             | 12                      | 7                 | Small quantity standard (see note) | 20  |
|                |                         |                   |                                    | 50  |
|                |                         |                   |                                    | 100 |
|                |                         |                   |                                    | 200 |
|                |                         | 13                | Standard                           | 500 |
| 1000           |                         |                   |                                    |     |

Note: Availability of small reel quantity varies by model.  
Refer to pricing and availability on individual model dashboard.

Mini-Circuits carrier tape materials provide protection from ESD (Electro-Static Discharge) during handling and transportation. Tapes are static dissipative and comply with industry standards EIA-481/EIA-541.

Go to: [www.minicircuits.com/pages/pdfs/tape.pdf](http://www.minicircuits.com/pages/pdfs/tape.pdf)



INTERNET <http://www.minicircuits.com>

P.O. Box 350166, Brooklyn, New York 11235-0003 (718) 934-4500 Fax (718) 332-4661

Distribution Centers NORTH AMERICA 800-654-7949 • 417-335-5935 • Fax 417-335-5945 • EUROPE 44-1252-832600 • Fax 44-1252-837010

Mini-Circuits ISO 9001 & ISO 14001 Certified



THIRD ANGLE PROJECTION

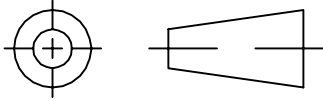

REVISIONS

| REV | ECN No. | DESCRIPTION                    | DATE     | DR  | AUTH |
|-----|---------|--------------------------------|----------|-----|------|
| OR  | M81002  | NEW RELEASE                    | 08/05/02 | MMG | LC   |
| A   | M102713 | ADDED NOTE 2 & "...WITH SMOBC" | 01/17/06 | MMG | IL   |
|     |         |                                |          |     |      |

**SUGGESTED MOUNTING CONFIGURATION  
FOR BH292/CD542 CASE STYLE, "It" PIN CONNECTION**

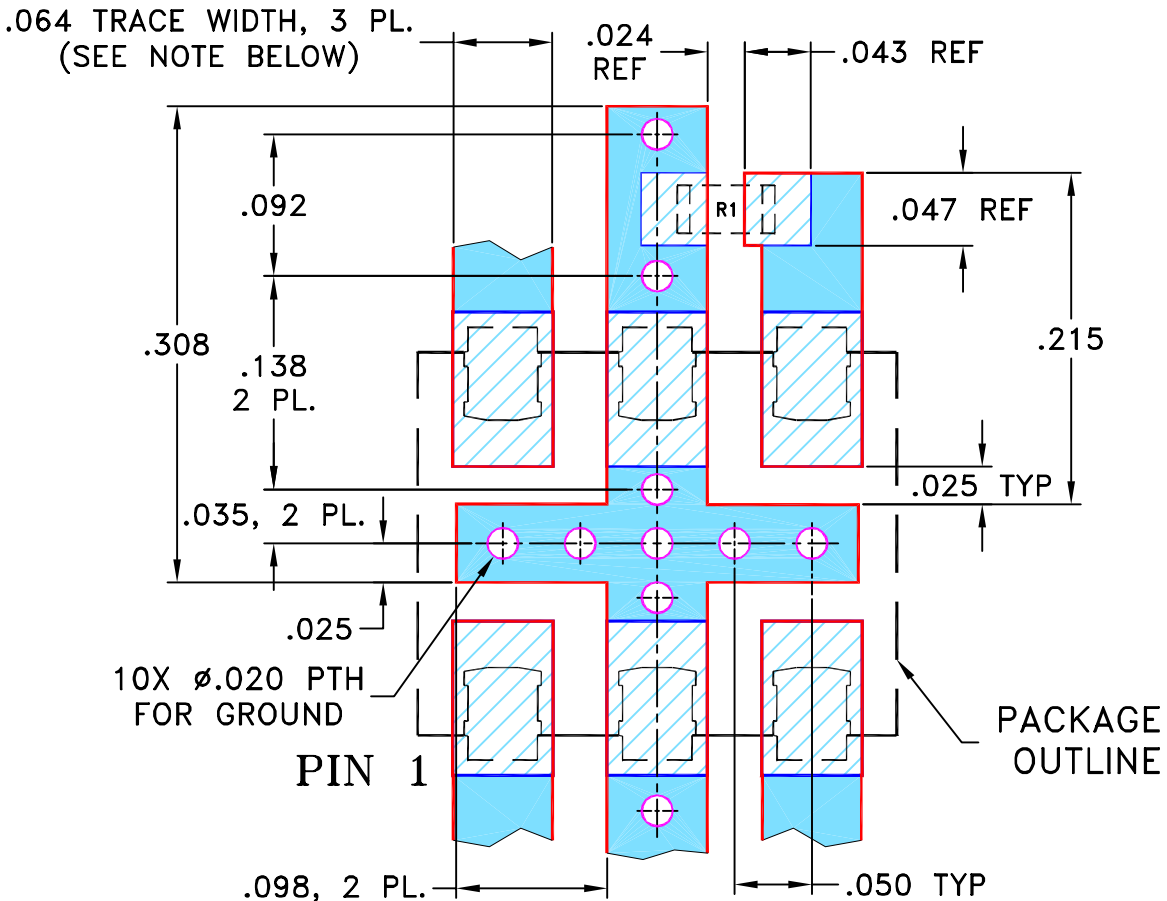

RESISTOR R1: 49.9 Ohm, 0603 SIZE.

- NOTES: 1. TRACE WIDTH IS SHOWN FOR ROGERS R04350B WITH DIELECTRIC THICKNESS .030" ± .002"; COPPER: 1/2 OZ. EACH SIDE. FOR OTHER MATERIALS TRACE WIDTH MAY NEED TO BE MODIFIED.  
2. BOTTOM SIDE OF THE PCB IS CONTINUOUS GROUND PLANE.

- DENOTES PCB COPPER LAYOUT WITH SMOBC (SOLDER MASK OVER BARE COPPER)
- DENOTES COPPER LAND PATTERN FREE OF SOLDER MASK

|                            |          |              |
|----------------------------|----------|--------------|
| UNLESS OTHERWISE SPECIFIED | INITIALS | DATE         |
|                            | DRAWN    | MMG 08/05/02 |
|                            | CHECKED  | AV 08/05/02  |
|                            | APPROVED | LC 08/05/02  |

**Mini-Circuits®** 13 Neptune Avenue  
Brooklyn NY 11235

PL, It, BH292/CD542, JDC/ADC, TB-176

Mini-Circuits®  
 THIS DOCUMENT AND ITS CONTENTS ARE THE PROPERTY OF MINI-CIRCUITS. EXCEPT FOR USE EXPRESSLY GRANTED, IN WRITING, TO ITS VENDORS, VENDEE AND THE UNITED STATES GOVERNMENT, MINI-CIRCUITS RESERVES ALL PROPRIETARY DESIGN, USE, MANUFACTURING AND REPRODUCTION RIGHTS THERETO. THESE CONTENTS SHALL NOT BE USED, DUPLICATED OR DISCLOSED TO ANY OUTSIDE PARTY, IN WHOLE OR IN PART, WITHOUT WRITTEN PERMISSION OF MINI-CIRCUITS.  
 ASHEETA1.DWG REV:A DATE:01/12/95

|       |            |             |        |
|-------|------------|-------------|--------|
| SIZE  | CODE IDENT | DRAWING NO: | REV:   |
| A     | 15542      | 98-PL-041   | A      |
| FILE: | 98PL041    | SCALE:      | SHEET: |
|       |            | 8:1         | 1 OF 1 |

# Evaluation Board and Circuit

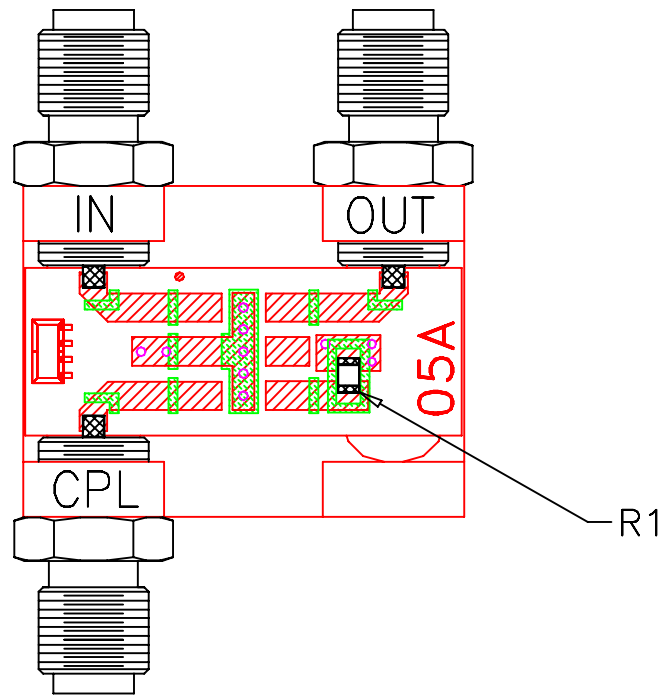

TB-05

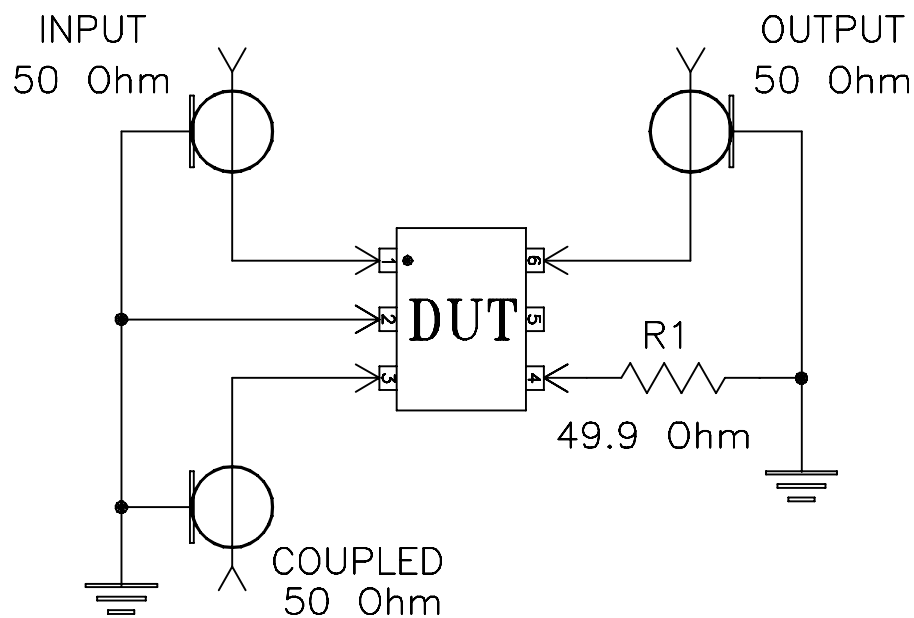

Schematic Diagram

## Notes:

1. SMA Female connectors.
2. PCB Material: Rogers R04350 or equivalent, Dielectric Constant=3.5, Thickness=.030 inch.

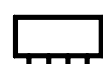
 Mini-Circuits®



All Mini-Circuits products are manufactured under exacting quality assurance and control standards, and are capable of meeting published specifications after being subjected to any or all of the following physical and environmental test.

| Specification                  | Test/Inspection Condition   | Reference/Spec   |
|--------------------------------|---|--|
| Operating Temperature          | -40° to 85°C<br>Ambient Environment   | Individual Model Data Sheet  |
| Storage Temperature            | -55° to 100° C<br>Ambient Environment   | Individual Model Data Sheet  |
| Humidity                       | 90 to 95% RH, 240 hours, 50°C   | MIL-STD-202, Method 103, Condition A, Except 50°C and end-point electrical test done within 12 hours |
| Thermal Shock                  | -55° to 100°C, 100 cycles   | MIL-STD-202, Method 107, Condition A-3, except +100°C  |
| Solder Reflow Heat             | Sn-Pb Eutetic Process: 225°C peak<br>Pb-Free Process 245° - 250°C peak  | J-STD-020, Table 4-1, 4-2 and 5-2, Figure 5-1  |
| Solderability                  | 10X Magnification   | J-STD-002, 95% Coverage  |
| Vibration (High Frequency)     | 20g peak, 10-2000 Hz, 12 times in each of three perpendicular directions (total 36)   | MIL-STD-202, Method 204, Condition D   |
| Mechanical Shock               | 50g, 11 ms, 1/2-sine, 18 shocks: 3 each direction, each of 3 axes   | MIL-STD-202, Method 213, Condition A   |
| Marking Resistance to Solvents | Isopropyl alcohol + mineral spirits at 25°C; terpene defluxer at 25°C;<br>distilled water + proylene glycol monomethyl ether + monoethanolamine at 63°C to 70°C | MIL-STD-202, Method 215  |