



SURFACE MOUNT

Power Splitter/Combiner

AD4PS-1+

Mini-Circuits

4 Way-0° 50Ω 1 to 500 MHz

FEATURES

- Wideband, 1 to 500 MHz
- High Isolation, 30 dB typ.
- Good input port matching VSWR, 1.12 typ.
- Good output port matching VSWR, 1.10 typ.
- Small size



Generic photo used for illustration purposes only

CASE STYLE: CJ725

+RoHS Compliant

The +Suffix identifies RoHS Compliance.
See our website for methodologies and qualifications

APPLICATIONS

- VHF-TV
- Aircraft Communications

ELECTRICAL SPECIFICATIONS

Parameter	Frequency (MHz)	Min.	Typ.	Max.	Unit
Frequency Range	—	1	—	500	MHz
Insertion Loss, above 6.0 dB	1 - 10	—	0.4	1.2	dB
	10 - 250	—	0.5	1.2	
	250 - 500	—	0.8	1.8	
Isolation	1 - 10	18	32	—	dB
	10 - 250	20	30	—	
	250 - 500	18	25	—	
Phase Unbalance	1 - 10	—	—	2	Degree
	10 - 250	—	—	5	
	250 - 500	—	—	7	
Amplitude Unbalance	1 - 10	—	—	0.4	dB
	10 - 250	—	—	0.5	
	250 - 500	—	—	0.8	

ABSOLUTE MAXIMUM RATINGS

Parameter	Ratings
Operating Temperature	-40°C to +85°C
Storage Temperature	-55°C to +100°C
Power Input (as a splitter)	0.5W Max.
Internal Dissipation	0.25W Max.

Permanent damage may occur if any of these limits are exceeded.

ELECTRICAL SCHEMATIC



REV. K
ECO-019621
AD4PS-1+
MCL NY
231031





SURFACE MOUNT

Power Splitter/Combiner

AD4PS-1+



4 Way-0° 50Ω 1 to 500 MHz

PIN CONNECTIONS

SUM PORT	2
PORT 1	8
PORT 2	7
PORT 3	6
PORT 4	5
GROUND	1,3,4

PRODUCT MARKING: N/A

DEMO BOARD MCL P/N: TB-81
SUGGESTED PCB LAYOUT (PL-072)

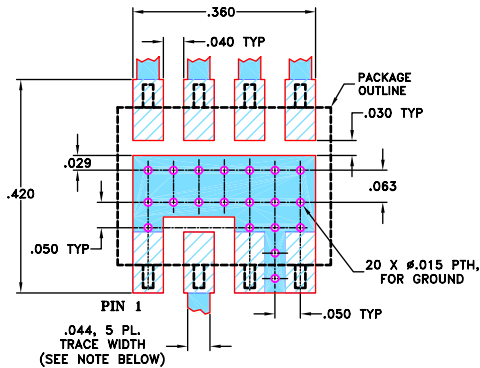

- NOTES: 1. TRACE WIDTH IS SHOWN FOR ROGERS R04350B WITH DIELECTRIC THICKNESS 0.020" ± 0.0015"; COPPER: 1/2 OZ. EACH SIDE. FOR OTHER MATERIALS TRACE WIDTH MAY NEED TO BE MODIFIED.
2. BOTTOM SIDE OF THE PCB IS CONTINUOUS GROUND PLANE.
- DENOTES PCB COPPER LAYOUT WITH SMOBC (SOLDER MASK OVER BARE COPPER)
 - DENOTES COPPER LAND PATTERN FREE OF SOLDER MASK

OUTLINE DRAWING

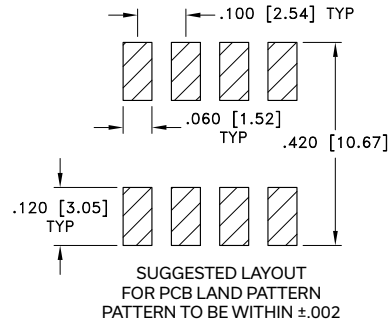
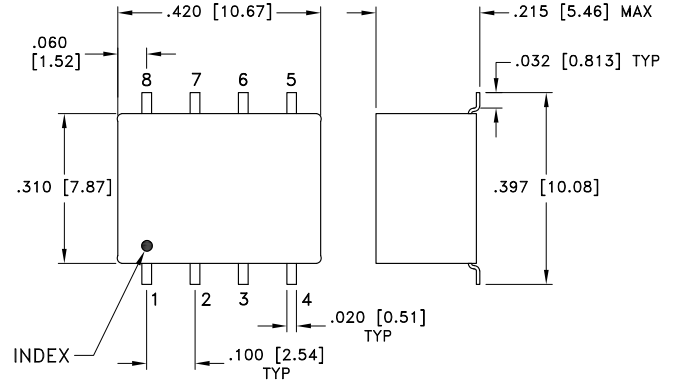

Weight: .40 gram
Dimensions are in inches [mm]. Tolerances: 2 Pl. ±.01; 3Pl. ±.005 Inch

- Notes:
- Case material: Plastic.
 - Termination Finish: Tin plate over Nickel plate.

TAPE & REEL INFORMATION: F10





SURFACE MOUNT

Power Splitter/Combiner

AD4PS-1+

Mini-Circuits

4 Way-0° 50Ω 1 to 500 MHz

TYPICAL PERFORMANCE DATA

Frequency (MHz)	Total Loss ¹ (dB)				Amplitude Unbalance (dB)	Isolation (dB)			Phase Unbalance (deg.)	VSWR (:1)				
	S-1	S-2	S-3	S-3		1-2	2-3	3-4		S	1	2	3	4
1.00	6.59	6.59	6.59	6.59	0.01	28.61	46.82	30.70	0.02	1.20	1.31	1.31	1.30	1.28
5.00	6.38	6.42	6.38	6.38	0.04	33.63	54.15	34.52	0.05	1.10	1.15	1.15	1.15	1.13
9.00	6.37	6.42	6.37	6.37	0.05	34.35	52.09	34.63	0.08	1.08	1.12	1.12	1.12	1.10
10.00	6.38	6.42	6.38	6.38	0.04	34.41	51.62	34.60	0.09	1.08	1.12	1.12	1.11	1.10
40.00	6.42	6.47	6.43	6.43	0.04	33.14	40.57	32.89	0.28	1.08	1.11	1.11	1.11	1.09
70.00	6.47	6.50	6.46	6.46	0.04	31.60	36.15	31.47	0.52	1.09	1.10	1.11	1.11	1.09
100.00	6.49	6.53	6.49	6.49	0.04	30.28	33.28	30.23	0.71	1.11	1.10	1.10	1.11	1.09
150.00	6.58	6.61	6.56	6.56	0.05	28.63	30.21	28.64	1.04	1.12	1.09	1.10	1.10	1.08
200.00	6.65	6.68	6.62	6.62	0.05	27.48	28.12	27.52	1.47	1.14	1.07	1.08	1.09	1.07
250.00	6.68	6.71	6.63	6.62	0.09	26.98	26.73	27.02	1.66	1.14	1.05	1.07	1.09	1.06
300.00	6.76	6.80	6.71	6.70	0.10	27.10	25.83	27.23	1.99	1.13	1.04	1.06	1.09	1.06
350.00	6.81	6.83	6.70	6.68	0.15	28.13	25.41	28.36	2.08	1.09	1.04	1.06	1.09	1.06
400.00	6.84	6.90	6.73	6.68	0.21	30.62	25.41	30.49	2.21	1.05	1.07	1.08	1.12	1.09
450.00	6.95	6.98	6.76	6.73	0.26	36.71	25.89	31.30	2.54	1.05	1.11	1.11	1.16	1.12
500.00	7.08	7.15	6.83	6.77	0.38	39.78	26.85	27.20	3.34	1.13	1.14	1.15	1.21	1.17

1. Total Loss = Insertion Loss + 6dB splitter loss.

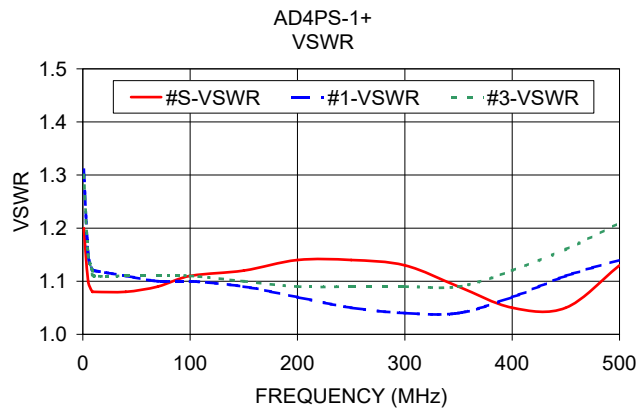
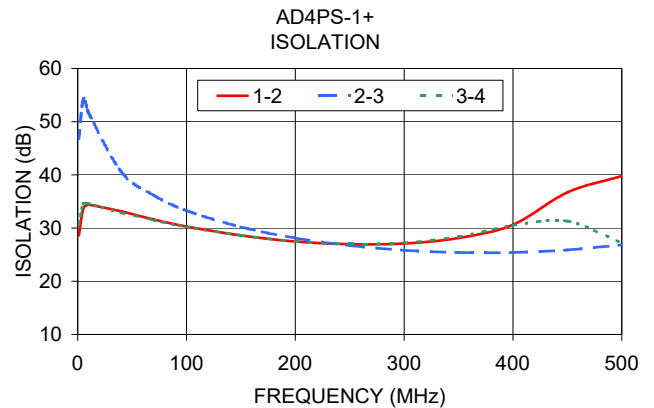
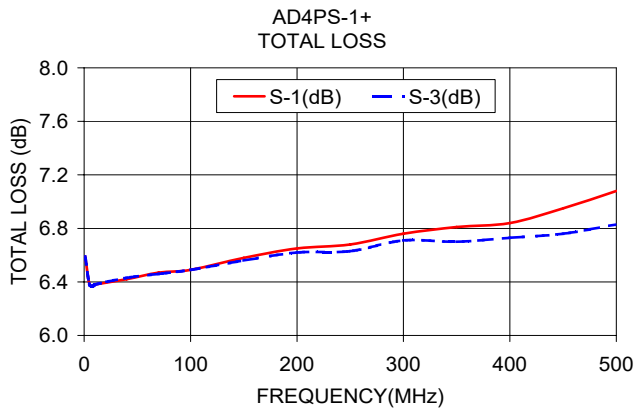

- NOTES**
- A. Performance and quality attributes and conditions not expressly stated in this specification document are intended to be excluded and do not form a part of this specification document.
 - B. Electrical specifications and performance data contained in this specification document are based on Mini-Circuit's applicable established test performance criteria and measurement instructions.
 - C. The parts covered by this specification document are subject to Mini-Circuits standard limited warranty and terms and conditions (collectively, "Standard Terms"); Purchasers of this part are entitled to the rights and benefits contained therein. For a full statement of the standard. Terms and the exclusive rights and remedies thereunder, please visit Mini-Circuits' website at www.minicircuits.com/terms/viewterm.html



4 Way-0° Power Splitter/Combiner

AD4PS-1+

Typical Performance Data

TEST CONDITIONS: INPUT POWER = 0 dBm @Temperature = +25°C

FREQ. (MHz)	TOTAL LOSS ¹ (dB)				AMP. UNBAL. (dB)	PHASE UNBAL. (deg.)	ISOLATION (dB)			VSWR (:1)				
	S-1	S-2	S-3	S-4			1-2	2-3	3-4	S	1	2	3	4
1	6.66	6.65	6.64	6.65	0.02	0.21	26.66	53.64	27.75	1.22	1.33	1.33	1.32	1.32
5	6.44	6.43	6.42	6.42	0.02	0.09	32.37	51.90	33.02	1.10	1.15	1.15	1.15	1.15
10	6.45	6.44	6.43	6.43	0.02	0.06	33.51	48.86	33.97	1.08	1.13	1.13	1.13	1.13
20	6.46	6.45	6.44	6.44	0.02	0.07	33.23	44.15	33.66	1.07	1.12	1.12	1.12	1.12
40	6.50	6.48	6.47	6.47	0.03	0.13	31.79	38.81	32.36	1.07	1.12	1.12	1.12	1.12
60	6.53	6.52	6.51	6.50	0.03	0.15	30.54	35.67	31.24	1.08	1.12	1.11	1.11	1.11
80	6.56	6.55	6.54	6.53	0.03	0.19	29.44	33.46	30.25	1.09	1.11	1.10	1.11	1.10
100	6.59	6.58	6.56	6.56	0.03	0.24	28.49	31.76	29.38	1.10	1.11	1.10	1.10	1.10
120	6.62	6.61	6.59	6.58	0.03	0.29	27.68	30.40	28.63	1.11	1.11	1.10	1.10	1.10
140	6.64	6.64	6.62	6.61	0.03	0.34	26.98	29.27	28.00	1.12	1.11	1.09	1.10	1.09
160	6.68	6.67	6.65	6.63	0.04	0.39	26.39	28.31	27.47	1.13	1.11	1.09	1.10	1.08
180	6.70	6.70	6.67	6.66	0.05	0.43	25.91	27.48	27.04	1.14	1.10	1.08	1.09	1.07
200	6.73	6.73	6.70	6.68	0.05	0.49	25.52	26.77	26.72	1.15	1.09	1.07	1.09	1.07
220	6.76	6.76	6.73	6.70	0.06	0.56	25.24	26.16	26.49	1.15	1.09	1.07	1.09	1.07
240	6.78	6.78	6.75	6.71	0.07	0.61	25.03	25.62	26.36	1.15	1.09	1.06	1.08	1.06
250	6.79	6.80	6.76	6.72	0.07	0.64	24.97	25.37	26.34	1.16	1.09	1.06	1.08	1.05
260	6.81	6.82	6.78	6.74	0.07	0.67	24.93	25.15	26.35	1.16	1.09	1.06	1.08	1.05
270	6.82	6.83	6.79	6.75	0.09	0.69	24.91	24.94	26.38	1.16	1.08	1.05	1.07	1.05
280	6.83	6.84	6.80	6.75	0.09	0.73	24.92	24.74	26.44	1.16	1.08	1.05	1.07	1.05
290	6.84	6.86	6.81	6.76	0.10	0.77	24.95	24.54	26.52	1.15	1.07	1.05	1.07	1.04
300	6.86	6.87	6.82	6.77	0.10	0.80	25.01	24.37	26.65	1.15	1.07	1.04	1.07	1.04
310	6.87	6.89	6.83	6.78	0.11	0.86	25.10	24.21	26.82	1.15	1.07	1.04	1.07	1.04
320	6.89	6.91	6.85	6.78	0.12	0.88	25.21	24.05	27.03	1.15	1.06	1.04	1.07	1.04
330	6.89	6.92	6.86	6.79	0.13	0.88	25.36	23.91	27.27	1.14	1.06	1.05	1.07	1.05
340	6.91	6.94	6.87	6.80	0.14	0.93	25.55	23.77	27.56	1.14	1.06	1.05	1.07	1.05
350	6.92	6.95	6.88	6.80	0.14	0.97	25.77	23.65	27.90	1.14	1.06	1.05	1.08	1.05
360	6.93	6.96	6.89	6.81	0.15	1.02	26.03	23.53	28.31	1.13	1.06	1.06	1.08	1.06
370	6.94	6.98	6.90	6.82	0.16	1.05	26.35	23.42	28.79	1.13	1.06	1.06	1.08	1.06
380	6.95	7.00	6.91	6.82	0.17	1.09	26.71	23.32	29.36	1.12	1.06	1.07	1.08	1.07
390	6.97	7.01	6.93	6.83	0.19	1.14	27.13	23.23	30.02	1.11	1.06	1.07	1.09	1.07
400	6.98	7.03	6.93	6.83	0.20	1.17	27.62	23.13	30.81	1.11	1.06	1.08	1.09	1.08
410	6.99	7.05	6.95	6.84	0.21	1.20	28.20	23.05	31.77	1.10	1.06	1.08	1.10	1.09
420	7.01	7.07	6.96	6.85	0.22	1.25	28.88	22.97	32.94	1.09	1.06	1.09	1.11	1.10
430	7.02	7.09	6.97	6.85	0.24	1.29	29.69	22.90	34.40	1.09	1.07	1.10	1.12	1.11
440	7.04	7.11	6.98	6.86	0.25	1.36	30.65	22.82	36.28	1.08	1.07	1.11	1.12	1.11
450	7.06	7.13	7.00	6.87	0.26	1.40	31.82	22.76	38.83	1.08	1.08	1.11	1.13	1.12
460	7.08	7.15	7.02	6.88	0.28	1.46	33.29	22.69	42.52	1.08	1.09	1.12	1.14	1.13
470	7.10	7.18	7.03	6.89	0.29	1.50	35.21	22.62	47.50	1.08	1.10	1.14	1.15	1.14
480	7.12	7.21	7.05	6.90	0.31	1.56	37.85	22.55	46.13	1.08	1.11	1.14	1.17	1.15
490	7.14	7.24	7.07	6.91	0.33	1.62	41.91	22.48	40.73	1.09	1.12	1.15	1.18	1.16
500	7.17	7.28	7.09	6.92	0.35	1.66	49.83	22.41	36.86	1.10	1.13	1.17	1.19	1.17
525	7.25	7.37	7.15	6.97	0.40	1.83	38.65	22.23	30.75	1.13	1.16	1.20	1.23	1.20
550	7.35	7.50	7.23	7.03	0.48	2.00	31.09	22.02	26.84	1.16	1.20	1.23	1.26	1.23
575	7.48	7.67	7.32	7.10	0.57	2.20	26.70	21.79	23.93	1.20	1.24	1.27	1.31	1.26
600	7.64	7.86	7.44	7.19	0.67	2.38	23.48	21.53	21.61	1.23	1.29	1.31	1.35	1.30
625	7.85	8.11	7.57	7.30	0.81	2.62	20.89	21.29	19.71	1.25	1.35	1.37	1.40	1.34
650	8.12	8.44	7.72	7.44	1.00	2.88	18.64	21.10	18.08	1.24	1.42	1.43	1.45	1.37
675	8.50	8.89	7.93	7.63	1.25	3.18	16.61	21.09	16.66	1.19	1.51	1.50	1.51	1.42
700	9.05	9.52	8.23	7.91	1.60	3.55	14.69	21.38	15.34	1.09	1.61	1.60	1.57	1.47

¹Total Loss = Insertion Loss + 6dB Splitter Loss



4 Way-0° Power Splitter/Combiner

AD4PS-1+

Typical Performance Data

TEST CONDITIONS: INPUT POWER = 0 dBm @Temperature = -40°C

FREQ. (MHz)	TOTAL LOSS ¹ (dB)				AMP. UNBAL. (dB)	PHASE UNBAL. (deg.)	ISOLATION (dB)			VSWR (:1)				
	S-1	S-2	S-3	S-4			1-2	2-3	3-4	S	1	2	3	4
1	6.92	6.92	6.90	6.91	0.02	0.19	24.40	44.06	25.54	1.32	1.52	1.52	1.50	1.50
5	6.51	6.50	6.49	6.50	0.02	0.09	30.10	50.25	31.10	1.15	1.24	1.24	1.23	1.22
10	6.41	6.40	6.39	6.40	0.02	0.08	33.33	50.98	34.08	1.09	1.15	1.15	1.14	1.14
20	6.37	6.35	6.35	6.35	0.03	0.08	34.83	45.91	35.19	1.06	1.10	1.09	1.09	1.09
40	6.38	6.36	6.35	6.35	0.03	0.12	33.70	39.68	34.09	1.06	1.07	1.07	1.07	1.07
60	6.41	6.39	6.38	6.38	0.03	0.14	32.33	36.38	32.82	1.09	1.07	1.07	1.07	1.07
80	6.44	6.42	6.41	6.40	0.03	0.17	31.11	34.08	31.72	1.11	1.08	1.08	1.08	1.08
100	6.45	6.44	6.43	6.42	0.04	0.22	30.06	32.34	30.77	1.11	1.09	1.08	1.08	1.07
120	6.47	6.46	6.44	6.44	0.04	0.28	29.17	30.93	29.96	1.11	1.08	1.06	1.07	1.06
140	6.50	6.49	6.47	6.45	0.05	0.31	28.42	29.77	29.28	1.14	1.07	1.05	1.06	1.05
160	6.53	6.53	6.50	6.49	0.05	0.34	27.79	28.79	28.73	1.17	1.07	1.05	1.07	1.06
180	6.55	6.55	6.52	6.50	0.05	0.37	27.28	27.94	28.29	1.17	1.08	1.06	1.07	1.06
200	6.57	6.57	6.54	6.51	0.06	0.43	26.87	27.19	27.94	1.17	1.09	1.06	1.07	1.05
220	6.59	6.59	6.56	6.53	0.07	0.48	26.55	26.54	27.70	1.17	1.08	1.05	1.06	1.04
240	6.62	6.62	6.58	6.54	0.08	0.54	26.33	25.97	27.57	1.19	1.07	1.04	1.05	1.04
250	6.63	6.63	6.59	6.55	0.08	0.56	26.26	25.70	27.55	1.19	1.07	1.03	1.05	1.04
260	6.65	6.65	6.61	6.57	0.09	0.58	26.22	25.46	27.57	1.19	1.07	1.03	1.05	1.04
270	6.65	6.67	6.62	6.57	0.10	0.61	26.21	25.24	27.61	1.19	1.07	1.04	1.06	1.04
280	6.66	6.67	6.63	6.58	0.10	0.63	26.21	25.01	27.68	1.19	1.07	1.04	1.06	1.05
290	6.66	6.68	6.63	6.57	0.11	0.64	26.24	24.81	27.78	1.18	1.07	1.04	1.06	1.04
300	6.68	6.69	6.64	6.58	0.12	0.69	26.31	24.61	27.92	1.18	1.07	1.04	1.06	1.04
310	6.69	6.71	6.65	6.59	0.12	0.73	26.40	24.43	28.10	1.18	1.07	1.04	1.06	1.04
320	6.70	6.72	6.66	6.60	0.13	0.75	26.53	24.26	28.32	1.18	1.07	1.04	1.06	1.04
330	6.71	6.74	6.67	6.60	0.14	0.78	26.70	24.09	28.60	1.17	1.07	1.04	1.06	1.04
340	6.72	6.75	6.68	6.60	0.15	0.83	26.90	23.94	28.93	1.17	1.06	1.05	1.06	1.04
350	6.73	6.76	6.69	6.61	0.16	0.84	27.15	23.79	29.31	1.16	1.06	1.05	1.06	1.04
360	6.74	6.78	6.70	6.61	0.17	0.89	27.44	23.66	29.78	1.16	1.05	1.05	1.06	1.05
370	6.75	6.79	6.71	6.61	0.18	0.92	27.80	23.52	30.32	1.14	1.05	1.05	1.07	1.05
380	6.76	6.81	6.72	6.62	0.19	0.95	28.20	23.40	30.96	1.13	1.05	1.06	1.08	1.06
390	6.77	6.82	6.72	6.62	0.20	1.00	28.68	23.29	31.72	1.12	1.05	1.07	1.09	1.07
400	6.78	6.83	6.73	6.62	0.21	1.02	29.25	23.17	32.62	1.12	1.06	1.07	1.10	1.08
410	6.79	6.85	6.74	6.63	0.22	1.06	29.93	23.07	33.71	1.11	1.06	1.08	1.10	1.09
420	6.81	6.87	6.75	6.63	0.24	1.11	30.72	22.97	35.00	1.10	1.07	1.09	1.11	1.09
430	6.82	6.88	6.76	6.63	0.25	1.16	31.69	22.87	36.56	1.09	1.08	1.09	1.11	1.10
440	6.84	6.90	6.77	6.63	0.27	1.19	32.85	22.77	38.35	1.09	1.08	1.10	1.12	1.11
450	6.85	6.92	6.78	6.64	0.28	1.24	34.29	22.68	40.11	1.08	1.09	1.10	1.13	1.12
460	6.87	6.95	6.80	6.65	0.30	1.30	36.13	22.59	40.86	1.08	1.10	1.11	1.14	1.13
470	6.88	6.97	6.81	6.66	0.31	1.32	38.60	22.50	39.72	1.08	1.10	1.12	1.16	1.14
480	6.90	6.99	6.83	6.67	0.32	1.38	41.94	22.41	37.48	1.09	1.11	1.13	1.17	1.15
490	6.92	7.02	6.85	6.68	0.35	1.41	45.47	22.32	35.13	1.09	1.12	1.15	1.19	1.17
500	6.95	7.05	6.86	6.69	0.36	1.47	44.01	22.23	33.01	1.10	1.13	1.16	1.20	1.18
525	7.02	7.15	6.92	6.72	0.42	1.62	34.74	21.99	28.76	1.13	1.17	1.19	1.24	1.21
550	7.11	7.26	6.98	6.77	0.49	1.77	29.38	21.73	25.58	1.17	1.21	1.23	1.27	1.24
575	7.23	7.41	7.07	6.84	0.58	1.96	25.70	21.46	23.04	1.21	1.25	1.27	1.32	1.29
600	7.37	7.59	7.16	6.91	0.69	2.13	22.82	21.16	20.94	1.24	1.29	1.32	1.37	1.32
625	7.57	7.83	7.27	7.00	0.82	2.34	20.41	20.88	19.17	1.25	1.36	1.38	1.41	1.36
650	7.81	8.13	7.41	7.12	1.01	2.61	18.27	20.67	17.64	1.24	1.43	1.44	1.45	1.40
675	8.16	8.54	7.59	7.28	1.26	2.89	16.30	20.63	16.30	1.19	1.51	1.52	1.52	1.44
700	8.67	9.14	7.85	7.53	1.61	3.21	14.40	20.89	15.02	1.09	1.61	1.63	1.59	1.49

¹Total Loss = Insertion Loss + 6dB Splitter Loss

REV. X2
AD4PS-1+
100623
Page 2 of 3



IF/RF MICROWAVE COMPONENTS • ISO 9001 ISO 14001 AS 9100 CERTIFIED • RoHS compliant
P.O. Box 350166, Brooklyn, New York 11235-0003 (718) 934-4500 Fax (718) 332-4661



The Design Engineers Search Engine finds the model you need, Instantly • For detailed performance specs & shopping online see



4 Way-0° Power Splitter/Combiner

AD4PS-1+

Typical Performance Data

TEST CONDITIONS: INPUT POWER = 0 dBm @Temperature = +85°C

FREQ. (MHz)	TOTAL LOSS ¹ (dB)				AMP. UNBAL. (dB)	PHASE UNBAL. (deg.)	ISOLATION (dB)			VSWR (:1)				
	S-1	S-2	S-3	S-4			1-2	2-3	3-4	S	1	2	3	4
1	6.80	6.80	6.79	6.79	0.01	0.17	26.60	59.18	26.63	1.24	1.35	1.35	1.35	1.35
5	6.58	6.57	6.56	6.55	0.02	0.09	31.16	55.35	31.38	1.12	1.19	1.19	1.19	1.19
10	6.60	6.59	6.58	6.57	0.03	0.08	31.62	50.00	31.99	1.11	1.17	1.17	1.17	1.17
20	6.62	6.60	6.60	6.59	0.03	0.10	31.16	44.13	31.65	1.11	1.17	1.17	1.17	1.17
40	6.66	6.64	6.63	6.62	0.04	0.14	29.98	38.42	30.60	1.11	1.18	1.18	1.18	1.18
60	6.69	6.67	6.67	6.65	0.03	0.17	28.90	35.19	29.63	1.09	1.18	1.18	1.18	1.17
80	6.72	6.70	6.69	6.68	0.04	0.23	27.92	32.95	28.74	1.08	1.16	1.15	1.15	1.15
100	6.75	6.73	6.72	6.71	0.04	0.26	27.05	31.25	27.95	1.10	1.14	1.14	1.14	1.14
120	6.79	6.77	6.76	6.74	0.05	0.26	26.31	29.90	27.26	1.12	1.14	1.14	1.14	1.14
140	6.81	6.80	6.79	6.77	0.05	0.32	25.67	28.79	26.68	1.12	1.15	1.14	1.15	1.14
160	6.84	6.83	6.81	6.79	0.05	0.40	25.12	27.85	26.18	1.10	1.15	1.13	1.14	1.13
180	6.86	6.85	6.83	6.80	0.06	0.44	24.66	27.05	25.77	1.10	1.14	1.11	1.13	1.11
200	6.89	6.88	6.86	6.83	0.07	0.45	24.28	26.36	25.44	1.11	1.12	1.09	1.11	1.09
220	6.93	6.92	6.90	6.86	0.07	0.53	24.01	25.77	25.22	1.12	1.11	1.09	1.11	1.09
240	6.95	6.94	6.92	6.87	0.08	0.57	23.80	25.24	25.08	1.12	1.11	1.08	1.11	1.09
250	6.97	6.96	6.93	6.89	0.08	0.59	23.73	25.01	25.04	1.11	1.10	1.08	1.11	1.08
260	6.98	6.97	6.95	6.90	0.08	0.59	23.68	24.79	25.03	1.11	1.10	1.08	1.10	1.07
270	6.99	6.99	6.96	6.91	0.08	0.65	23.66	24.59	25.03	1.11	1.10	1.08	1.10	1.07
280	7.01	7.00	6.97	6.92	0.09	0.66	23.65	24.39	25.07	1.11	1.10	1.07	1.09	1.06
290	7.02	7.02	6.98	6.92	0.10	0.71	23.66	24.21	25.12	1.12	1.09	1.06	1.09	1.05
300	7.04	7.03	7.00	6.93	0.10	0.76	23.70	24.05	25.21	1.12	1.08	1.06	1.08	1.05
310	7.06	7.05	7.02	6.95	0.11	0.79	23.77	23.89	25.34	1.12	1.08	1.06	1.08	1.05
320	7.07	7.07	7.03	6.96	0.12	0.80	23.86	23.75	25.49	1.11	1.07	1.05	1.08	1.05
330	7.08	7.09	7.05	6.97	0.12	0.82	23.98	23.62	25.68	1.11	1.07	1.05	1.08	1.05
340	7.10	7.10	7.06	6.98	0.13	0.85	24.13	23.50	25.91	1.10	1.06	1.06	1.08	1.06
350	7.11	7.12	7.07	6.98	0.14	0.87	24.31	23.39	26.18	1.10	1.06	1.06	1.09	1.06
360	7.12	7.14	7.09	6.99	0.14	0.92	24.53	23.29	26.50	1.10	1.06	1.06	1.09	1.06
370	7.14	7.16	7.10	7.00	0.15	0.94	24.79	23.19	26.89	1.09	1.06	1.07	1.09	1.07
380	7.15	7.17	7.11	7.01	0.16	1.00	25.08	23.11	27.33	1.09	1.06	1.07	1.09	1.07
390	7.17	7.19	7.13	7.02	0.18	1.03	25.43	23.04	27.84	1.09	1.06	1.08	1.10	1.07
400	7.18	7.21	7.14	7.02	0.19	1.08	25.83	22.96	28.44	1.09	1.06	1.09	1.10	1.08
410	7.20	7.23	7.15	7.03	0.20	1.15	26.30	22.91	29.16	1.08	1.06	1.09	1.11	1.09
420	7.22	7.25	7.17	7.04	0.21	1.20	26.84	22.85	30.01	1.08	1.06	1.10	1.11	1.09
430	7.23	7.28	7.18	7.05	0.23	1.27	27.47	22.80	31.04	1.07	1.07	1.10	1.12	1.10
440	7.26	7.30	7.19	7.05	0.24	1.32	28.20	22.75	32.29	1.07	1.07	1.11	1.12	1.11
450	7.27	7.32	7.21	7.07	0.25	1.39	29.05	22.71	33.88	1.07	1.08	1.12	1.13	1.12
460	7.30	7.35	7.23	7.08	0.27	1.43	30.06	22.67	35.97	1.07	1.09	1.13	1.14	1.13
470	7.31	7.38	7.25	7.09	0.28	1.47	31.27	22.64	38.86	1.08	1.10	1.14	1.16	1.14
480	7.34	7.40	7.27	7.11	0.30	1.55	32.73	22.60	43.31	1.08	1.11	1.15	1.17	1.15
490	7.37	7.44	7.29	7.12	0.32	1.56	34.48	22.57	48.97	1.09	1.12	1.17	1.18	1.16
500	7.40	7.48	7.32	7.14	0.34	1.59	36.47	22.54	44.32	1.10	1.13	1.18	1.19	1.17
525	7.49	7.59	7.39	7.19	0.39	1.68	37.97	22.45	33.78	1.13	1.17	1.21	1.22	1.19
550	7.60	7.72	7.48	7.25	0.47	1.77	32.10	22.33	28.56	1.17	1.20	1.24	1.26	1.23
575	7.74	7.90	7.59	7.34	0.55	1.83	27.41	22.19	25.07	1.20	1.25	1.28	1.30	1.26
600	7.92	8.11	7.71	7.45	0.67	1.87	23.96	22.00	22.41	1.23	1.30	1.32	1.35	1.30
625	8.15	8.39	7.87	7.58	0.81	1.81	21.23	21.81	20.28	1.25	1.36	1.37	1.40	1.33
650	8.46	8.75	8.06	7.74	1.00	1.79	18.90	21.67	18.51	1.24	1.42	1.43	1.45	1.37
675	8.87	9.23	8.30	7.97	1.26	2.06	16.85	21.69	17.00	1.20	1.51	1.51	1.51	1.41
700	9.45	9.90	8.63	8.28	1.63	2.32	14.93	22.02	15.61	1.10	1.61	1.60	1.57	1.46

¹Total Loss = Insertion Loss + 6dB Splitter Loss



4 Way-0° Power Splitter/Combiner

AD4PS-1+

Typical Performance Curves

Total Loss

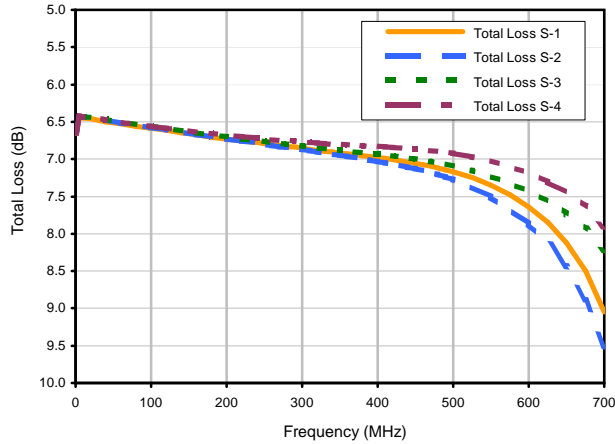

Total Loss S-1 vs. TEMPERATURE

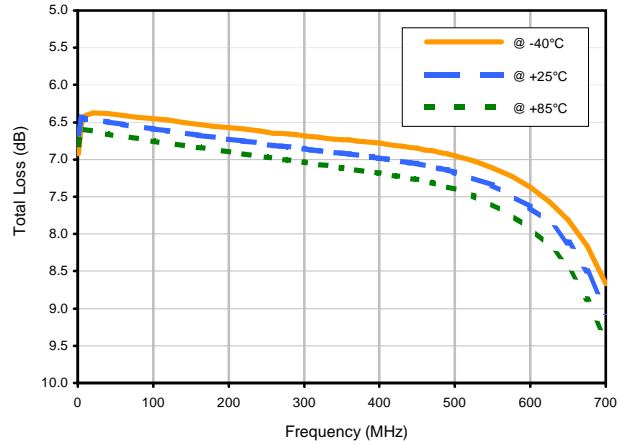

Amplitude Unbalance vs. TEMPERATURE

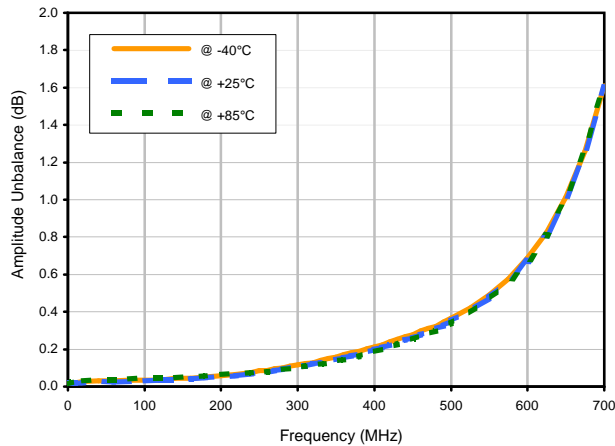

Phase Unbalance vs. TEMPERATURE

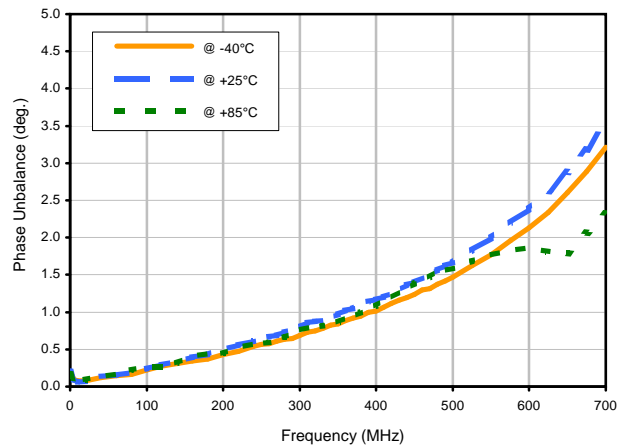

Isolation

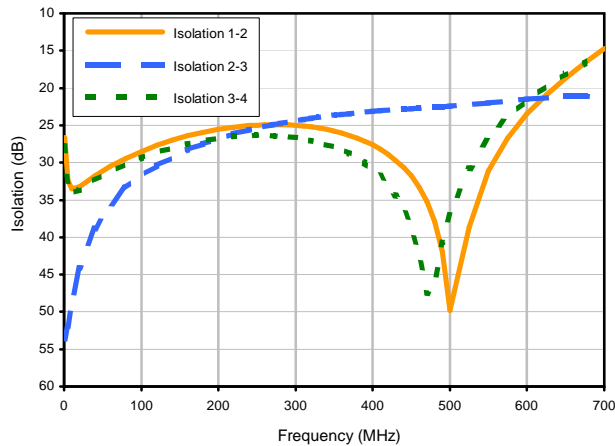

Isolation 1-2 vs. TEMPERATURE

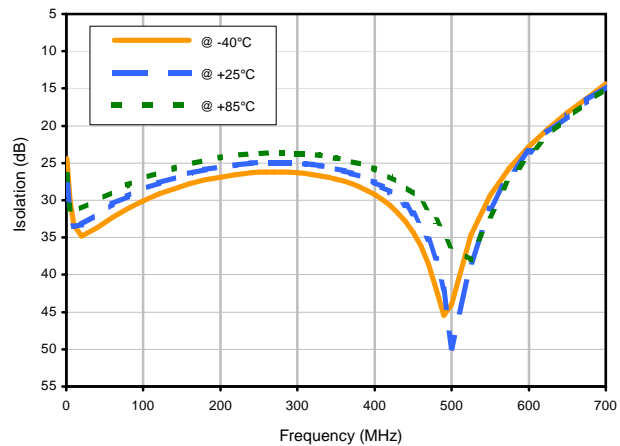

REV. X2
AD4PS-1+
100623
Page 1 of 2



IF/RF MICROWAVE COMPONENTS • ISO 9001 ISO 14001 AS 9100 CERTIFIED RoHS compliant
P.O. Box 350166, Brooklyn, New York 11235-0003 (718) 934-4500 Fax (718) 332-4661



The Design Engineers Search Engine finds the model you need, Instantly • For detailed performance specs & shopping online see



Typical Performance Curves

VSWR

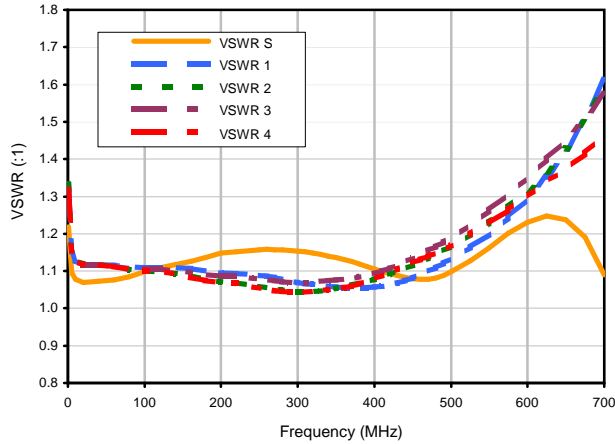

VSWR SUM vs. TEMPERATURE

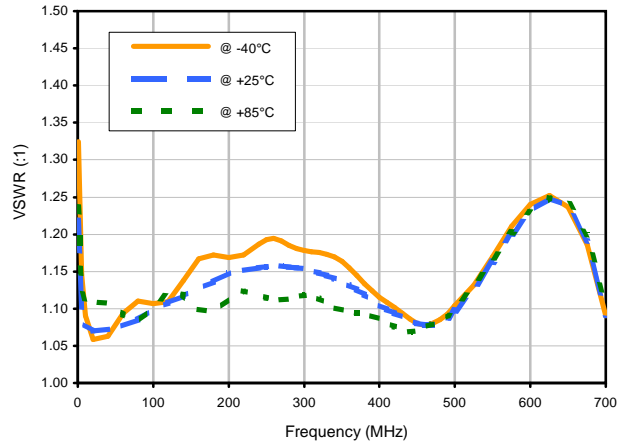

VSWR OUT1 vs. TEMPERATURE

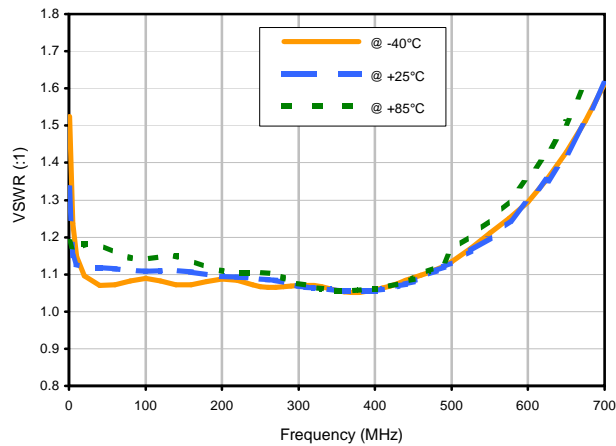

Case Style

CJ

Outline Dimensions

CJ725

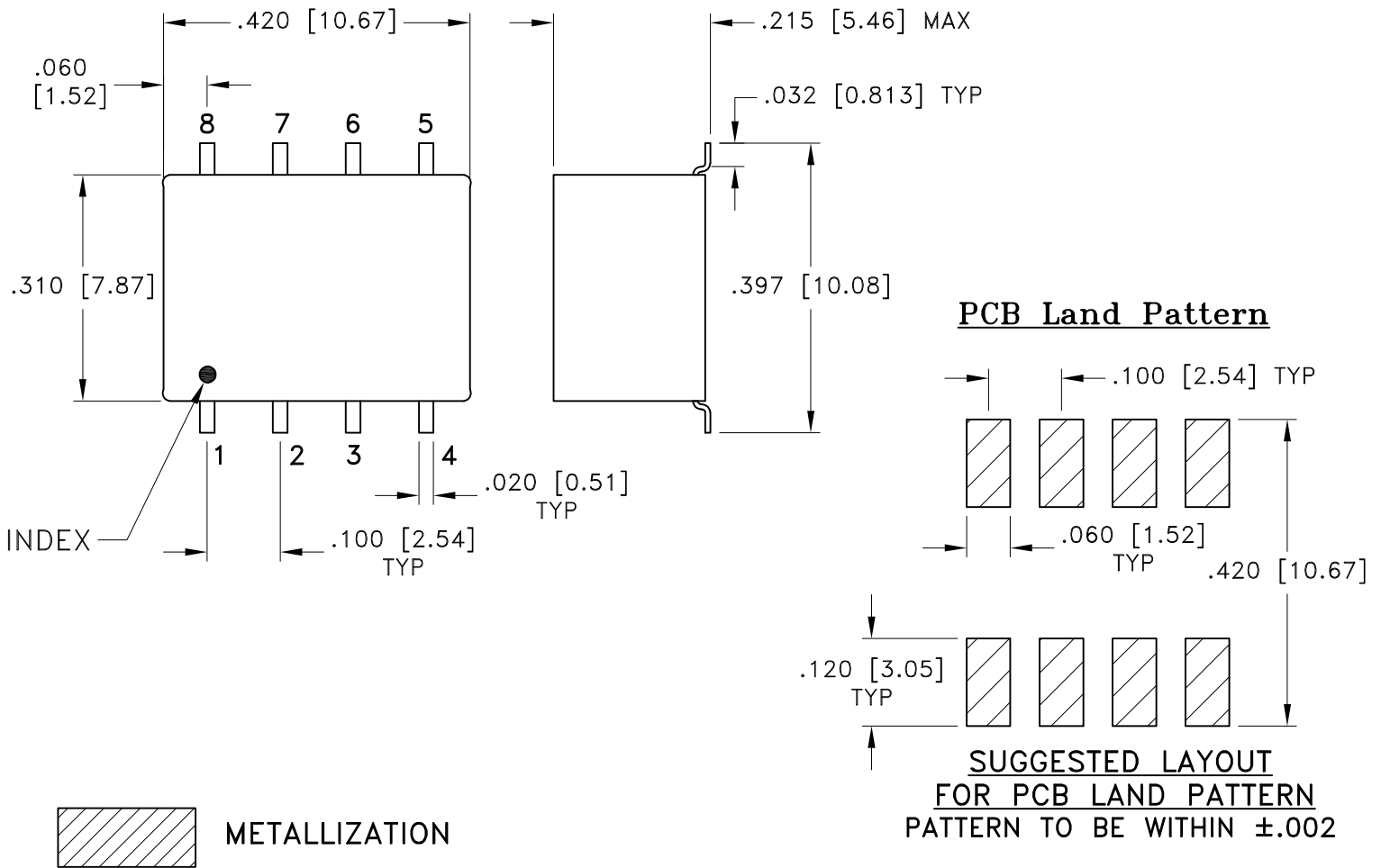

Weight: .40 gram

Dimensions are in inches [mm]. Tolerances: 2 Pl. ± 0.01 ; 3 Pl. ± 0.005 Inch

Notes:

1. Case material: Plastic.
2. Termination finish:
Tin plate over Nickel plate.

Mini-Circuits®
ISO 9001 ISO 14001 CERTIFIED

ALL NEW
minicircuits.com

P.O. Box 350166, Brooklyn, New York 11235-0003 (718) 934-4500 Fax (718) 332-4661 For detailed performance specs & shopping online see Mini-Circuits web site



The Design Engineers Search Engine Provides ACTUAL Data Instantly From MINI-CIRCUITS At: www.minicircuits.com

RF/IF MICROWAVE COMPONENTS

Tape & Reel Packaging TR-F10

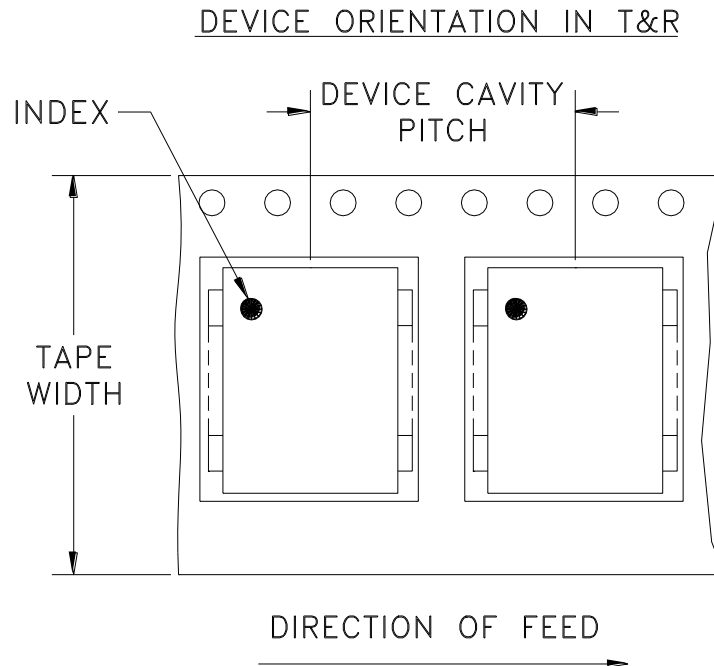

Tape Width, mm	Device Cavity Pitch, mm	Reel Size, inches	Devices per Reel
24	16	7	10,20,50,100,200
		13	500

Mini-Circuits carrier tape materials provide protection from ESD (Electro-Static Discharge) during handling and transportation. Tapes are static dissipative and comply with industry standards EIA-481/EIA-541.

Go to: www.minicircuits.com/pages/pdfs/tape.pdf

Note: Please consult individual model data sheet to determine device per reel availability.



INTERNET <http://www.minicircuits.com>

P.O. Box 350166, Brooklyn, New York 11235-0003 (718) 934-4500 Fax (718) 332-4661

Distribution Centers NORTH AMERICA 800-654-7949 • 417-335-5935 • Fax 417-335-5945 • EUROPE 44-1252-832600 • Fax 44-1252-837010

Mini-Circuits ISO 9001 & ISO 14001 Certified

THIRD ANGLE PROJECTION

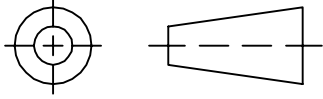

REVISIONS

REV	ECN No.	DESCRIPTION	DATE	DR	AUTH
OR	M82272	NEW RELEASE	08/05/02	GF	DJ
A	M102713	UPDATED NOTES	01/14/06	GF	IL

SUGGESTED MOUNTING CONFIGURATION FOR CJ725 CASE STYLES, "kb" PIN CONNECTION

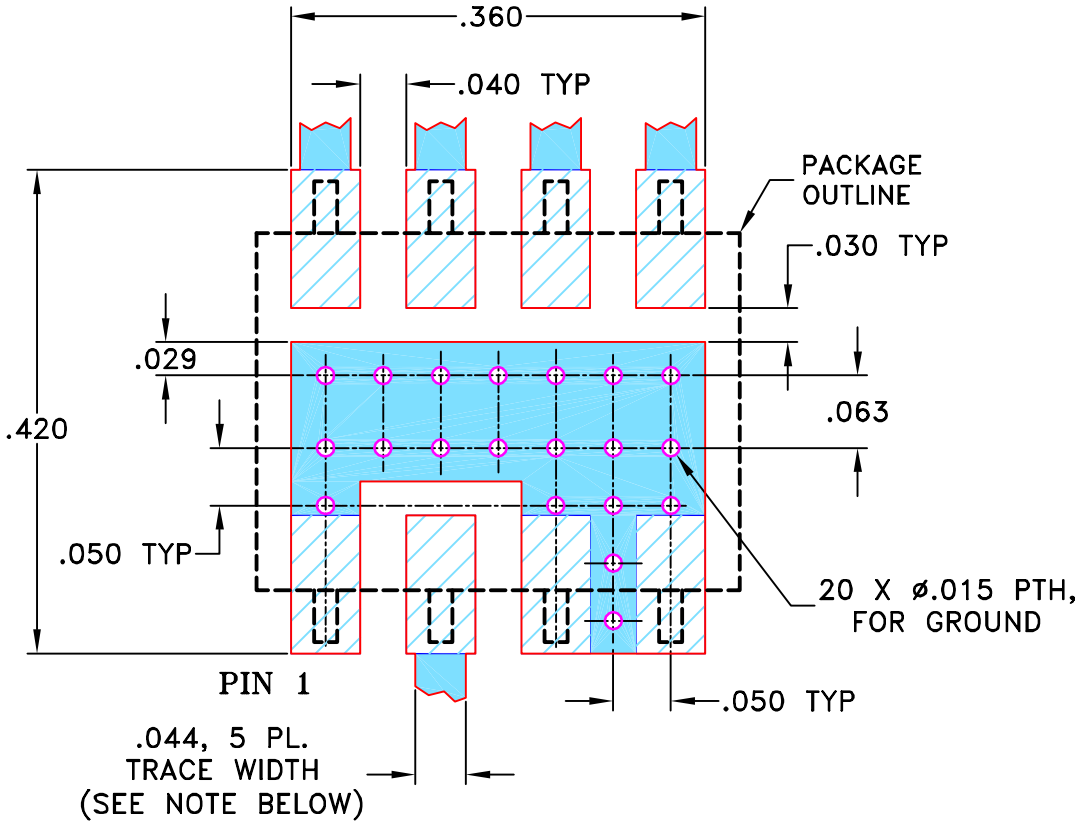

NOTES: 1. TRACE WIDTH IS SHOWN FOR ROGERS RO4350B WITH DIELECTRIC THICKNESS 0.020" ± 0.0015"; COPPER: 1/2 OZ. EACH SIDE. FOR OTHER MATERIALS TRACE WIDTH MAY NEED TO BE MODIFIED.

2. BOTTOM SIDE OF THE PCB IS CONTINUOUS GROUND PLANE.

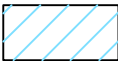
-  DENOTES PCB COPPER LAYOUT WITH SMOBC (SOLDER MASK OVER BARE COPPER)
-  DENOTES COPPER LAND PATTERN FREE OF SOLDER MASK

UNLESS OTHERWISE SPECIFIED	INITIALS	DATE
DRAWN	GF	07/18/02
CHECKED	HY	08/01/02
APPROVED	DJ	08/05/02

 **Mini-Circuits**[®] 13 Neptune Avenue
Brooklyn NY 11235

PL, kb, CJ725, AD4PS-1, TB-81

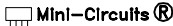
 Mini-Circuits[®]
THIS DOCUMENT AND ITS CONTENTS ARE THE PROPERTY OF MINI-CIRCUITS. EXCEPT FOR USE EXPRESSLY GRANTED, IN WRITING, TO ITS VENDORS, VEEDEE AND THE UNITED STATES GOVERNMENT, MINI-CIRCUITS RESERVES ALL PROPRIETARY DESIGN, USE, MANUFACTURING AND REPRODUCTION RIGHTS THERETO. THESE CONTENTS SHALL NOT BE USED, DUPLICATED OR DISCLOSED TO ANY OUTSIDE PARTY, IN WHOLE OR IN PART, WITHOUT WRITTEN PERMISSION OF MINI-CIRCUITS.

SIZE A	CODE IDENT 15542	DRAWING NO: 98-PL-072	REV: A
FILE: 98PL072	SCALE: 6:1	SHEET: 1 OF 1	

Evaluation Board and Circuit

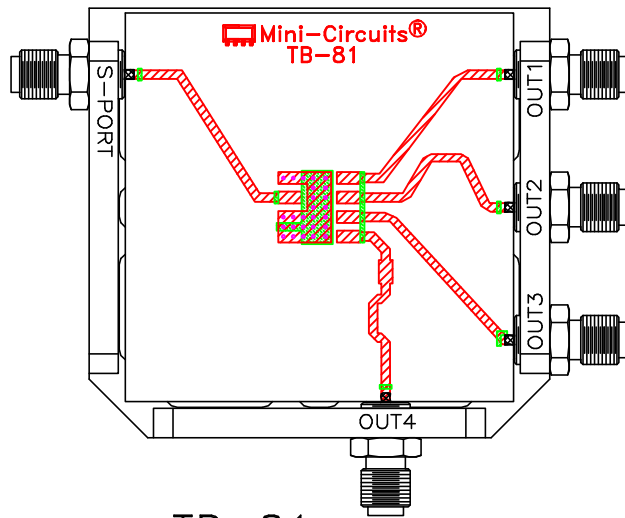

TB-81

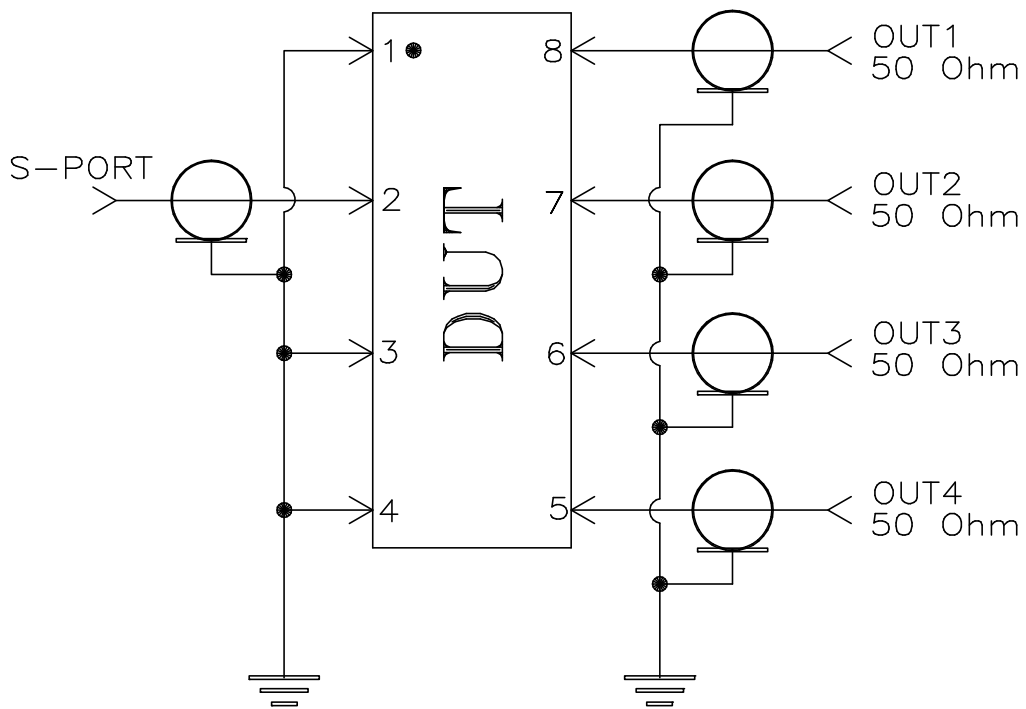

Schematic Diagram

Notes:

1. SMA Female connectors.
2. PCB Material: Rogers R04350 or equivalent,
Dielectric Constant=3.5, Thickness=.020 inch.

 **Mini-Circuits®**



All Mini-Circuits products are manufactured under exacting quality assurance and control standards, and are capable of meeting published specifications after being subjected to any or all of the following physical and environmental test.

Specification	Test/Inspection Condition	Reference/Spec
Operating Temperature	-40° to 85°C Ambient Environment	Individual Model Data Sheet
Storage Temperature	-55° to 100° C Ambient Environment	Individual Model Data Sheet
Humidity	90 to 95% RH, 240 hours, 50°C	MIL-STD-202, Method 103, Condition A, Except 50°C and end-point electrical test done within 12 hours
Thermal Shock	-55° to 100°C, 100 cycles	MIL-STD-202, Method 107, Condition A-3, except +100°C
Solder Reflow Heat	Sn-Pb Eutetic Process: 225°C peak Pb-Free Process 245° - 250°C peak	J-STD-020, Table 4-1, 4-2 and 5-2, Figure 5-1
Solderability	10X Magnification	J-STD-002, 95% Coverage
Vibration (High Frequency)	20g peak, 10-2000 Hz, 12 times in each of three perpendicular directions (total 36)	MIL-STD-202, Method 204, Condition D
Mechanical Shock	50g, 11 ms, 1/2-sine, 18 shocks: 3 each direction, each of 3 axes	MIL-STD-202, Method 213, Condition A
Marking Resistance to Solvents	Isopropyl alcohol + mineral spirits at 25°C; terpene defluxer at 25°C; distilled water + proylene glycol monomethyl ether + monoethanolamine at 63°C to 70°C	MIL-STD-202, Method 215