



COAXIAL

# Adapter

## 10M-10M+

Mini-Circuits

50Ω DC to 110 GHz 1.0mm-Male to 1.0mm-Male

### KEY FEATURES

- Ultra-wideband, DC to 110GHz
- Low Insertion Loss, 0.35 dB Typ.
- Straight Body
- Excellent VSWR, 1.06:1 Typ.



Generic photo used for illustration purposes only

### PRODUCT OVERVIEW

Mini-Circuits' 10M-10M+ is a coaxial 1.0mm Male to 1.0mm Male adapter supporting a wide range of applications from DC to 110 GHz. This model provides excellent VSWR and low insertion loss versus frequency. The 10M-10M+ features passivated stainless-steel construction and measures only 0.57" in length.

### ELECTRICAL SPECIFICATIONS AT +25°C

Parameter	Condition (GHz)	Min.	Typ.	Max.	Units
Frequency Range		DC		110	GHz
Insertion Loss	0.01-30	—	0.17	0.68	dB
	30-60	—	0.29	0.68	
	60-90	—	0.42	0.68	
	90-110	—	0.52	0.68	
VSWR	0.01-30	—	1.04	1.25	:1
	30-60	—	1.04	1.25	
	60-90	—	1.04	1.25	
	90-110	—	1.11	1.25	

Absolute Maximum Ratings are on page 3.



COAXIAL

# Adapter

10M-10M+

Mini-Circuits

50Ω DC to 110 GHz 1.0mm-Male to 1.0mm-Male

## TYPICAL PERFORMANCE GRAPHS

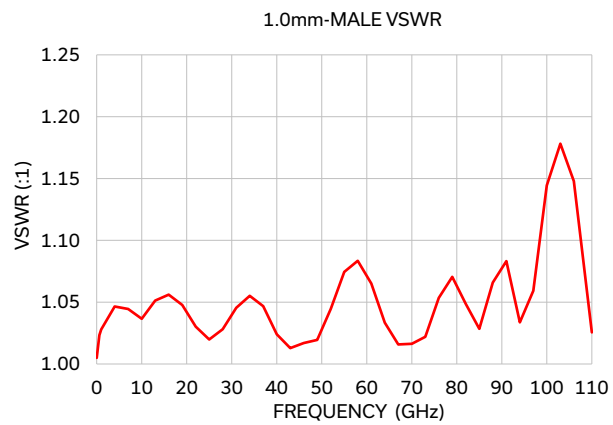
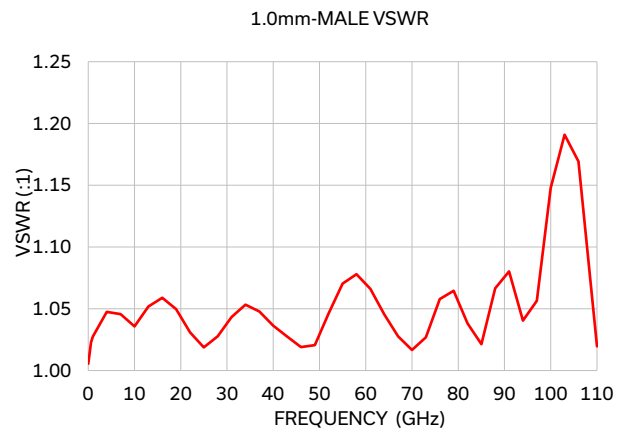



COAXIAL

# Adapter

# 10M-10M+

Mini-Circuits

50Ω DC to 110 GHz 1.0mm-Male to 1.0mm-Male

### ABSOLUTE MAXIMUM RATINGS<sup>1</sup>

Parameter	Ratings
Operating Case Temperature	+10 °C to +40 °C
Storage Temperature	+10 °C to +40 °C

1. Permanent damage may occur if any of these limits are exceeded.

### CONNECTOR SPECIFICATIONS

Description	Connector 1	Connector 2
Connector Type	1.00mm Male	1.00mm Male
Orientation	Straight	Straight

### CASE STYLE DRAWING

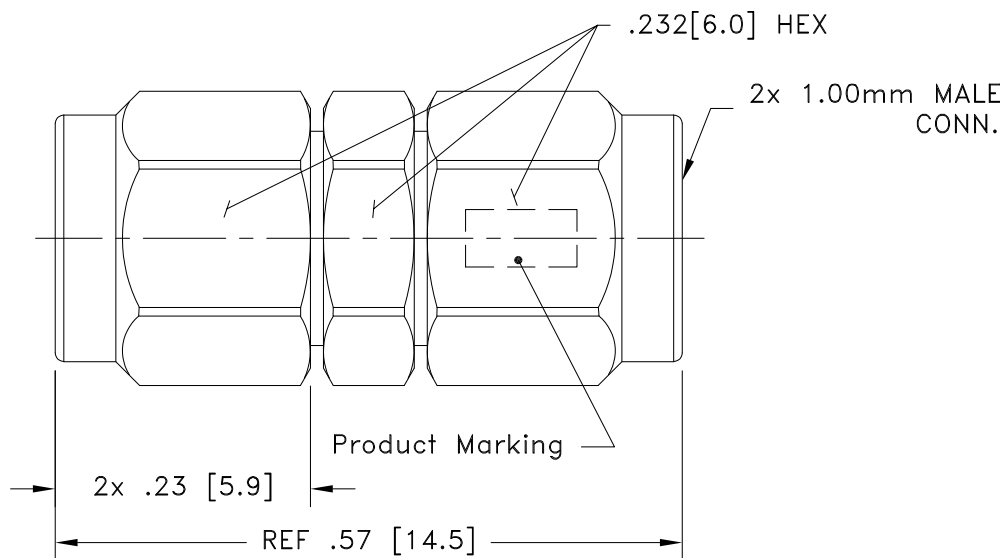

Weight: 2.6 grams

Dimensions are in inches [mm]. Tolerances: 2 Pl.  $\pm .03$ ; 3 Pl.  $\pm .015$  inches

### PRODUCT MARKING\*: 10M-10M+

\*Marking may contain other features or characters for internal lot control.

ADDITIONAL INFORMATION IS AVAILABLE ON OUR DASHBOARD

[CLICK HERE](#)

Performance	Data Graphs S-Parameter (S2P Files) Data Set (.zip file)
Case Style	DJ3474-2
RoHs Status	Compliant
Environmental Ratings	ENV127T1

#### NOTES

- A. Performance and quality attributes and conditions not expressly stated in this specification document are intended to be excluded and do not form a part of this specification document.
- B. Electrical specifications and performance data contained in this specification document are based on Mini-Circuit's applicable established test performance criteria and measurement instructions.
- C. The parts covered by this specification document are subject to Mini-Circuits standard limited warranty and terms and conditions (collectively, "Standard Terms"); Purchasers of this part are entitled to the rights and benefits contained therein. For a full statement of the standard terms and the exclusive rights and remedies thereunder, please visit Mini-Circuits' website at [www.minicircuits.com/terms/viewterm.html](http://www.minicircuits.com/terms/viewterm.html)



**Adaptor 1.0mm-Male to 1.0mm-Male****10M-10M+***Typical Performance Data*

FREQ.	INSERTION LOSS	1.0mm-MALE VSWR	1.0mm-MALE VSWR
(GHz)	(dB)	(:1)	(:1)
0.01	0.00	1.01	1.00
0.6	0.06	1.02	1.02
1.0	0.08	1.03	1.03
4.0	0.15	1.05	1.05
7.0	0.19	1.05	1.04
10.0	0.20	1.04	1.04
13.0	0.20	1.05	1.05
16.0	0.20	1.06	1.06
19.0	0.20	1.05	1.05
22.0	0.20	1.03	1.03
25.0	0.22	1.02	1.02
28.0	0.22	1.03	1.03
31.0	0.23	1.04	1.05
34.0	0.24	1.05	1.06
37.0	0.25	1.05	1.05
40.0	0.26	1.04	1.02
43.0	0.28	1.03	1.01
46.0	0.29	1.02	1.02
49.0	0.31	1.02	1.02
52.0	0.32	1.05	1.04
55.0	0.34	1.07	1.07
58.0	0.35	1.08	1.08
61.0	0.36	1.07	1.07
64.0	0.38	1.05	1.03
67.0	0.39	1.03	1.02
70.0	0.40	1.02	1.02
73.0	0.41	1.03	1.02
76.0	0.42	1.06	1.05
79.0	0.43	1.06	1.07
82.0	0.44	1.04	1.05
85.0	0.45	1.02	1.03
88.0	0.46	1.07	1.07
91.0	0.47	1.08	1.08
94.0	0.48	1.04	1.03
97.0	0.50	1.06	1.06
100.0	0.54	1.15	1.14
103.0	0.56	1.19	1.18
106.0	0.55	1.17	1.15
110.0	0.55	1.02	1.03



P.O. Box 350166, Brooklyn, New York 11235-0003 (718) 934-4500 • Fax (718) 332-4661 For detailed performance specs & shopping online see Mini-Circuits web site  
 The Design Engineers Search Engine Provides ACTUAL Data Instantly From MINI-CIRCUITS At: [www.minicircuits.com](http://www.minicircuits.com)



IF/RF MICROWAVE COMPONENTS

REV. OR  
 10M-10M+  
 3/9/2023  
 Page 1 of 1

## Typical Performance Curves

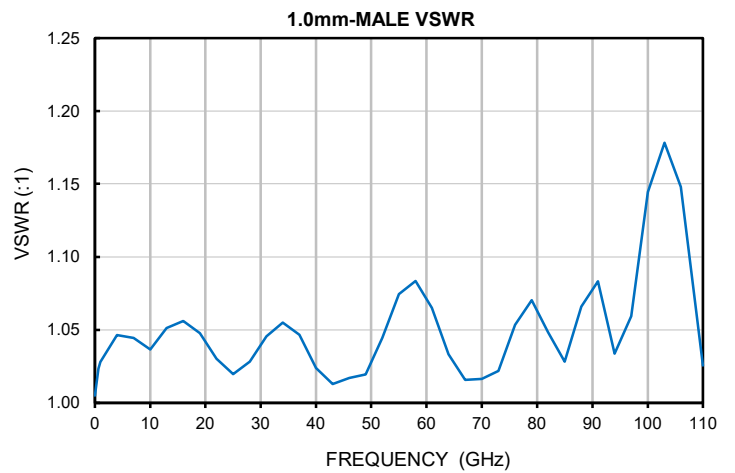
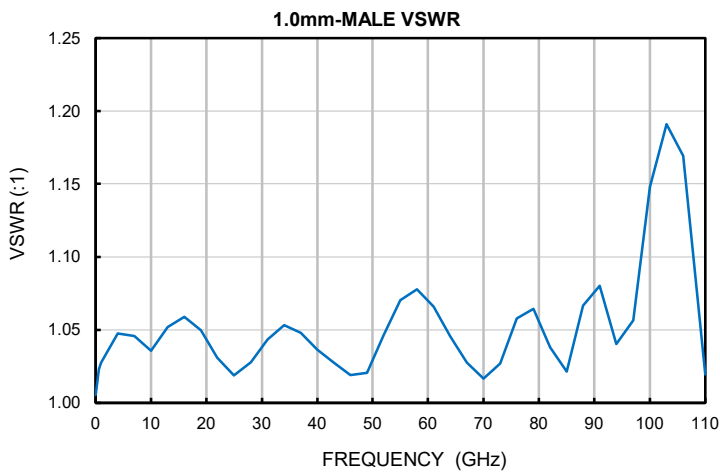
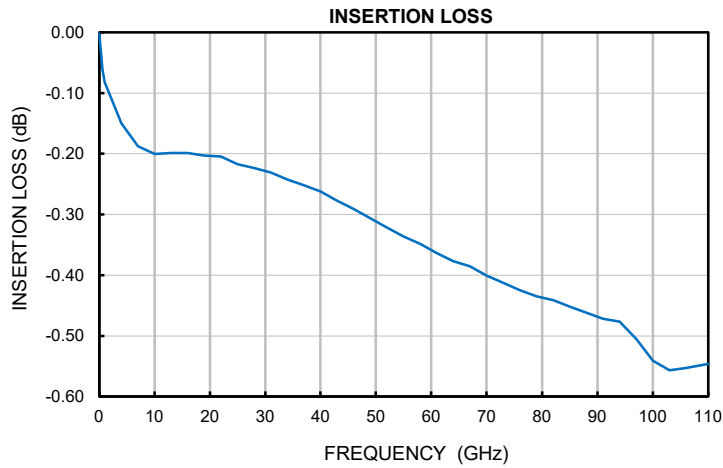

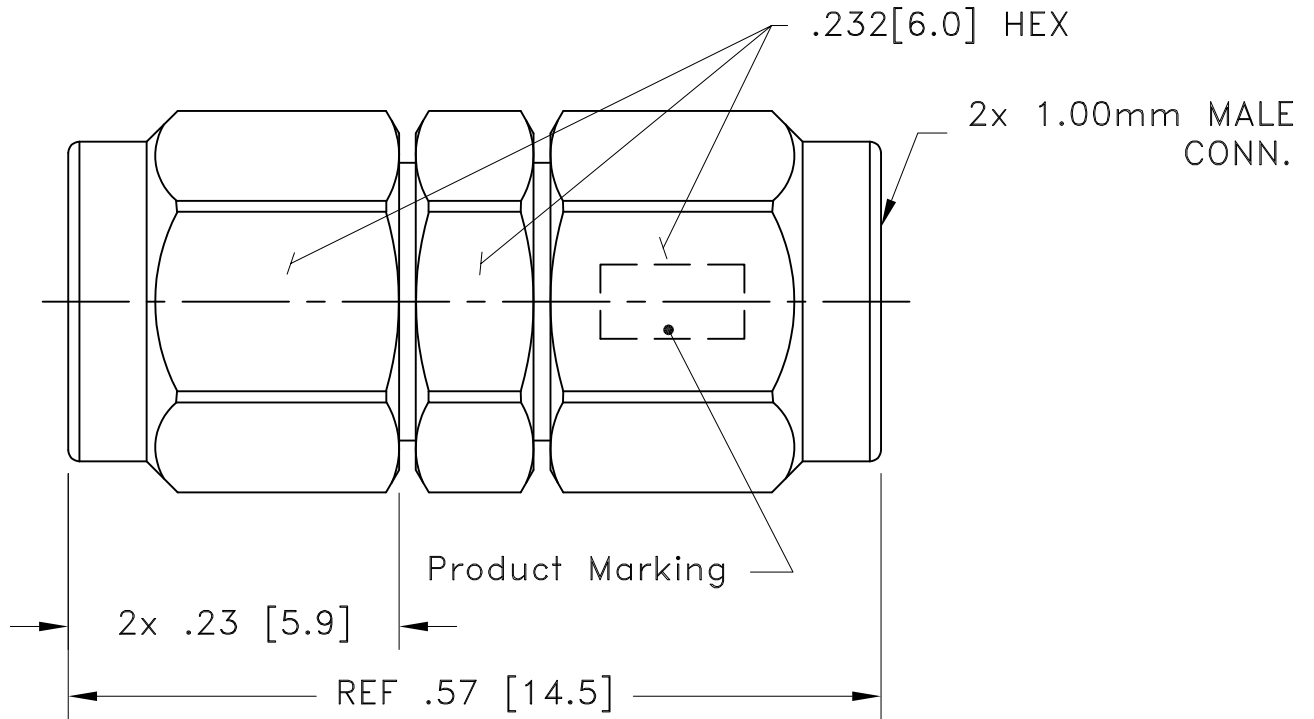

Weight: 2.6 grams

Dimensions are in inches [mm]. Tolerances: 2 Pl.±.03; 3 Pl. ±.015 inches

Notes:

1. Case material: Stainless Steel
2. Case Finish: Passivation



P.O. Box 350166, Brooklyn, New York 11235-0003 (718) 934-4500 Fax (718) 332-4661 For detailed performance specs & shopping online see Mini-Circuits web site



The Design Engineers Search Engine Provides ACTUAL Data Instantly From MINI-CIRCUITS At: [www.minicircuits.com](http://www.minicircuits.com)

RF/IF MICROWAVE COMPONENTS



All Mini-Circuits products are manufactured under exacting quality assurance and control standards, and are capable of meeting published specifications after being subjected to any or all of the following physical and environmental test.

Specification	Test/Inspection Condition	Reference/Spec
Operating Temperature	+10° to +40° C	Individual Model Data Sheet
Storage Temperature	+10° to +40° C	Individual Model Data Sheet
Thermal shock	+10° C to +40° C, 5 cycles, 15 min dwell time	MIL-STD-202, Method 107
Connector Durability	500 mating/unmating cycles	MIL-PRF-39012E, PARAGRAPH 4.6.12