



HAND FLEX™

# Coaxial Cable

086-8SMPR+

Mini-Circuits

50Ω 8 inch DC to 18 GHz Right Angle SMP-Female (Snap-on)

## THE BIG DEAL

- Wideband frequency coverage, DC to 18 GHz
- Low Loss, 0.8 dB at 18 GHz
- Excellent Return Loss, 24 dB at 18 GHz
- Hand formable to almost any custom shape without special bending tools
- 6mm bend radius for tight installations
- Insulated outer jacket standard
- Connector interface, meets MIL-STD-348
- Ideal for interconnect of assembled systems



Generic photo used for illustration purposes only

Model No.	086-8SMPR+
Case Style	KP2131-8
Connectors	Right Angle SMP-F (Snap-on)

### +RoHS Compliant

The +Suffix identifies RoHS Compliance. See our website for methodologies and qualifications

## APPLICATIONS

- Communication receivers and transmitters
- Military and aerospace system
- Environmental and test chambers

## PRODUCT OVERVIEW

086-SMPR+ Series Hand-Flex™ interconnect cables are ideal for interconnecting coaxial components and sub-assemblies in a wide range of systems. Rugged, hand-formable cable construction provides a minimum bend radius of 6mm to accommodate tight layouts without the need for bending tools, adapters or brackets. The connector interface meets MIL-STD-348 requirements and an insulated outer jacket protects against wear and tear. 086-SMPR+ cables are available in a variety of lengths to meet your requirements.

## KEY FEATURES

Feature	Advantages
Hand-formable RF cables	Facilitates interconnection of assembled systems without the need for special cable-bending tools or adapt-ers. Reduces the risk of damage during bending.
Tight bend-radius	6mm bend-radius allows almost any custom shape, accommodating tight layouts.
Right-angle SMP-F blind mate snap-on connectors	Ideal for interconnect of adjacent modules with tight space constraints without sacrificing high-frequency performance due to severe bend near the connector interface.
Excellent Return Loss	Minimizes VSWR ripple contribution due to mating cables and connectors.
Low Insertion Loss	Minimizes overall signal path loss.
Good power handling <ul style="list-style-type: none"> <li>• 87W at 0.5 GHz</li> <li>• 15W at 18 GHz</li> </ul>	Supports medium to high RF power levels used in transmit paths.

REV. A  
ECO-017668  
086-8SMPR+  
MCL NY  
240319





# Coaxial Cable

50Ω 8 inch DC to 18 GHz Right Angle SMP-Female (Snap-on)

### ELECTRICAL SPECIFICATIONS AT +25°C

Parameter	Frequency (GHz)	Min.	Typ.	Max.	Units
Frequency Range		DC		18	GHz
Length <sup>1</sup>		8			inches
Insertion Loss	DC - 2	—	0.3	0.6	dB
	2 - 6	—	0.5	0.9	
	6 - 10	—	0.7	1.1	
	10 - 18	—	0.9	1.5	
Return Loss	DC - 2	20.3	26.4	—	dB
	2 - 6	20.3	21.0	—	
	6 - 10	16	17.9	—	
	10 - 18	16	17.7	—	

1. Custom sizes available, consult factory.

### ABSOLUTE MAXIMUM RATINGS

Parameter	Ratings
Operating Temperature	-55°C to +105°C
Storage Temperature	-55°C to +105°C
Power Handling at +25°C, Sea Level	87W at 0.5 GHz
	85W at 1 GHz
	81W at 2 GHz
	65W at 6 GHz
	48W at 10 GHz
	15W at 18 GHz

Permanent damage may occur if any of these limits are exceeded.



HAND FLEX™

# Coaxial Cable

086-8SMPR+

Mini-Circuits

50Ω 8 inch DC to 18 GHz Right Angle SMP-Female (Snap-on)

## CABLE CONSTRUCTION

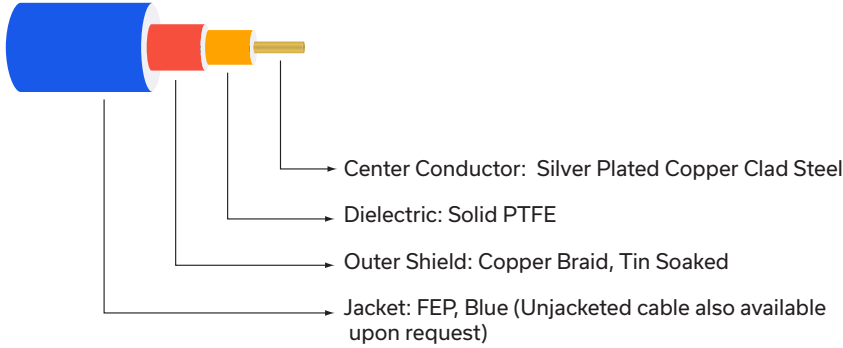

Connectors: Coupling Nut: Stainless Steel Passivated  
 Body: Stainless Steel Gold Plated  
 Center Pin: Brass, Gold Plated

## OUTLINE DRAWING

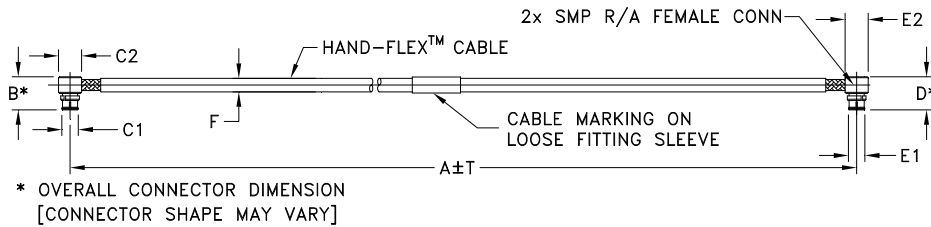

## OUTLINE DIMENSIONS (Inch/mm)

A	B	C1	C2	D	E1	E2	F	T	wt
8.0	.27	.135	.19	.27	.135	.19	.108 NOM	INCH	grams
203.20	6.86	3.43	4.83	6.86	3.43	4.8	2.74 NOM	0.5	4.86





### TYPICAL PERFORMANCE DATA AND CHARTS

Frequency (MHz)	Insertion Loss (dB)	Return Loss (dB)	
		Right Angle SMP - Female	Right Angle SMP - Female
10	0.02	47.77	47.79
100	0.05	42.03	42.09
200	0.08	37.27	37.33
400	0.12	36.39	36.36
1000	0.18	32.19	32.23
2000	0.26	28.07	28.62
3000	0.31	26.58	29.13
4000	0.36	27.32	30.79
6000	0.43	27.17	27.47
8000	0.50	25.64	28.42
10000	0.49	27.16	25.70
12000	0.60	28.27	26.43
14000	0.64	26.43	30.97
16000	0.66	28.82	32.36
18000	0.59	25.38	28.24

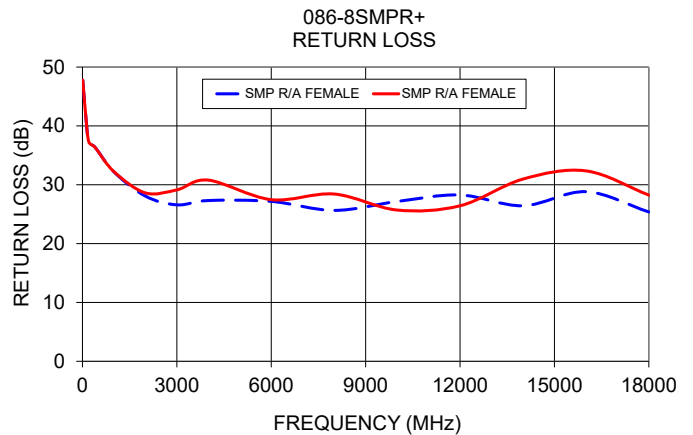
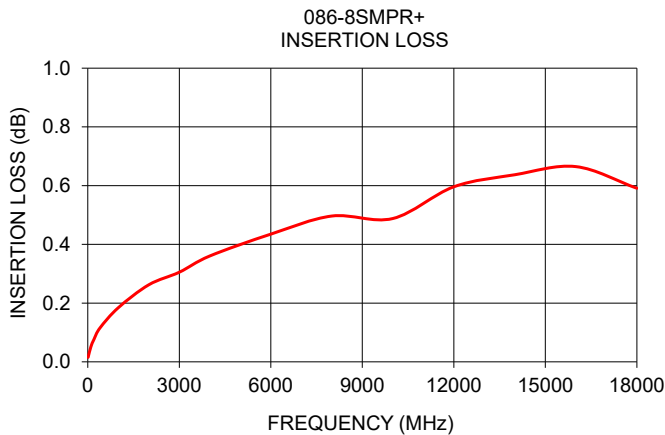

#### NOTES

- A. Performance and quality attributes and conditions not expressly stated in this specification document are intended to be excluded and do not form a part of this specification document.
- B. Electrical specifications and performance data contained in this specification document are based on Mini-Circuit's applicable established test performance criteria and measurement instructions.
- C. The parts covered by this specification document are subject to Mini-Circuits standard limited warranty and terms and conditions (collectively, "Standard Terms"); Purchasers of this part are entitled to the rights and benefits contained therein. For a full statement of the standard terms and the exclusive rights and remedies thereunder, please visit Mini-Circuits' website at [www.minicircuits.com/terms/viewterm.html](http://www.minicircuits.com/terms/viewterm.html)

## Typical Performance Data

FREQUENCY (MHz)	INSERTION LOSS (dB)	RIGHT ANGLE SMP-FEMALE 1 RETURN LOSS (dB)	RIGHT ANGLE SMP-FEMALE 2 RETURN LOSS (dB)
10	0.02	47.8	47.8
50	0.04	45.3	45.3
100	0.05	42.0	42.1
200	0.08	37.3	37.3
300	0.10	36.1	36.1
400	0.12	36.4	36.4
500	0.13	38.8	38.8
600	0.14	45.7	43.9
700	0.15	45.8	44.1
800	0.16	39.0	38.8
900	0.17	33.3	33.6
1000	0.18	32.2	32.2
1100	0.19	34.5	34.4
1250	0.21	38.3	41.3
1500	0.23	29.8	30.2
1750	0.23	35.1	37.9
2000	0.26	28.1	28.6
2001	0.26	28.1	28.6
2250	0.27	32.1	35.9
2500	0.29	27.2	28.9
2750	0.29	30.5	33.1
3000	0.31	26.6	29.1
3250	0.33	29.8	30.8
3500	0.35	27.0	30.9
3750	0.35	27.7	27.5
4000	0.36	27.3	30.8
4250	0.37	27.9	27.7
4500	0.38	27.9	31.3
5000	0.40	28.0	29.8
5500	0.42	29.3	30.2
6000	0.43	27.2	27.5
6500	0.45	27.4	27.0
7000	0.47	28.4	29.1
7500	0.48	25.8	27.2
8000	0.50	25.6	28.4
8500	0.50	24.5	27.0
9000	0.47	24.9	26.9
9500	0.53	26.1	26.2
10000	0.49	27.2	25.7
10500	0.54	26.7	26.6
11000	0.56	27.7	26.7
11500	0.60	29.5	26.1
12000	0.60	28.3	26.4
12500	0.62	27.8	27.7
13000	0.61	26.0	27.5
13500	0.63	27.5	30.7
14000	0.64	26.4	31.0
14500	0.64	26.4	32.2
15000	0.66	27.6	31.3
15500	0.66	28.1	32.5
16000	0.66	28.8	32.4
16500	0.63	26.8	27.6
17000	0.71	26.2	27.2
17500	0.71	26.9	28.0
18000	0.59	25.4	28.2

### Typical Performance Curves

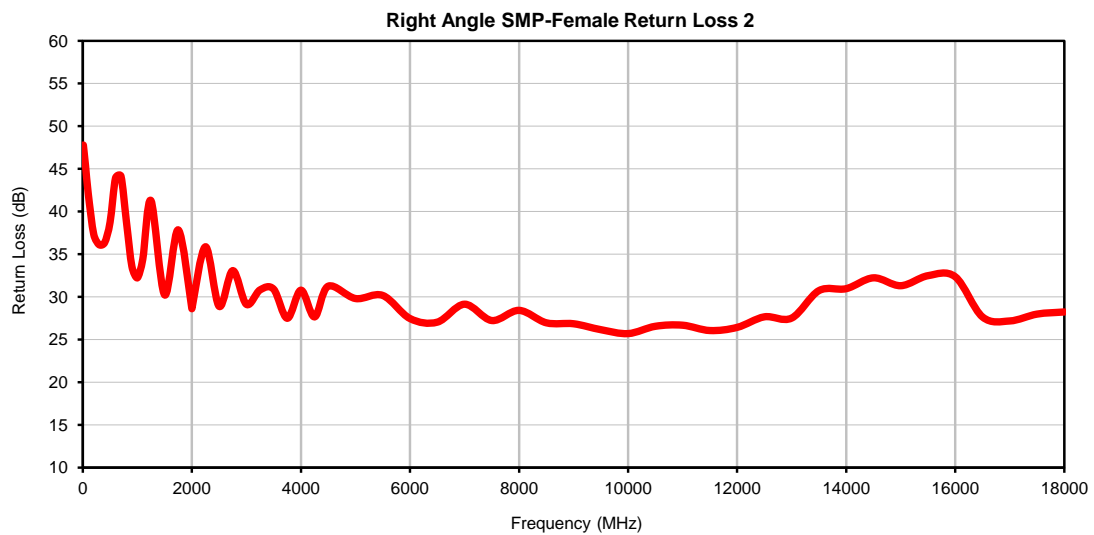
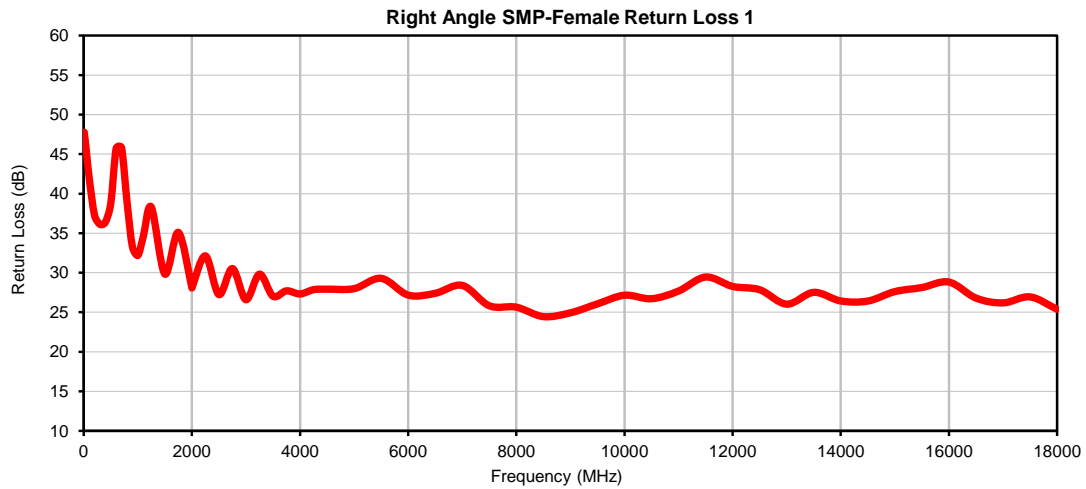

### Outline Dimensions

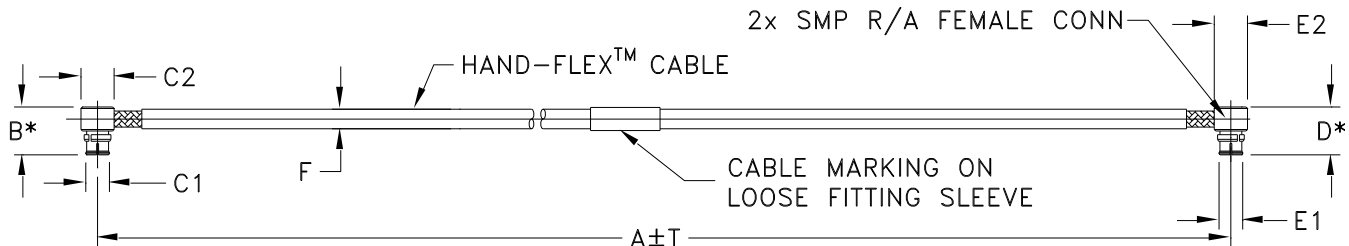

\* OVERALL CONNECTOR DIMENSION  
[CONNECTOR SHAPE MAY VARY]

KP2131 SERIES  
SMP R/A FEMALE (CONN-1)  
SMP R/A FEMALE (CONN-2)

CASE STYLE #	A		B	C1	C2	D	E1	E2	F		G	H	T		WEIGHT GRAMS
	INCH	MM							086U-ASMRC+	086-ASMRC+			INCH	MM	
KP2131-5	5.00	127.00	.27 (6.8)	.135 (3.43)	.19 (4.8)	.27 (6.8)	.135 (3.43)	.19 (4.8)	.089±.002 (2.26±.05)	.108 NOM (2.74 NOM)	--	--	.05	1.27	3.29
KP2131-8	8.00	203.20											.05	1.27	4.66
KP2131-10	10.00	254.00											.10	2.54	5.57

Unless otherwise specified dimensions are in inches (mm).

Tolerances: 2Pl. ± .03; 3Pl. ± .015

#### Note:

1. 086 Hand-Flex™ Coaxial Cable.
2. "A" represents length of cable.



INTERNET <http://www.minicircuits.com>

P.O. Box 350166, Brooklyn, New York 11235-0003 (718) 934-4500 Fax (718) 332-4661

Distribution Centers NORTH AMERICA 800-654-7949 • 417-335-5935 • Fax 417-335-5945 • EUROPE 44-1252-832600 • Fax 44-1252-837010

Mini-Circuits ISO 9001 & ISO 14001 Certified



All Mini-Circuits products are manufactured under exacting quality assurance and control standards, and are capable of meeting published specifications after being subjected to any or all of the following physical and environmental test.

Specification	Test/Inspection Condition	Reference/Spec
Operating Temperature	-55° to 105° C or -55° to 85° C (see datasheet) Ambient Environment	Individual Model Data sheet
Storage Temperature	-55° to 105° C or -55° to 85° C (see data sheet) Ambient Environment	Individual Model Data Sheet
Thermal Shock	-55° to 100°C, 100 Cycles	MIL-STD-202F; Method 107G
Multiple Bend Radius	40 mm, 5 times for 141 series cables 30 mm, 5 times for 086 series cables	
Single Bend Radius	8 mm for 141 series cables 6 mm for 086 series cables	