

Coaxial

# Voltage Controlled Oscillator

## ZX95-928C+

Low Noise 902 to 928 MHz

### Features

- high power output, +10 dBm typ.
- linear tuning characteristics
- very low phase noise
- low pushing
- 5V tuning voltage range
- protected by US patent 6,790,049



CASE STYLE: GB956

Connectors	Model
SMA	ZX95-928C-S+

### Applications

- r & d
- lab
- instrumentation
- RFID reader
- defense communication

**+RoHS Compliant**  
The +Suffix identifies RoHS Compliance. See our web site for RoHS Compliance methodologies and qualifications

### Electrical Specifications

MODEL NO.	FREQ. (MHz)		POWER OUTPUT (dBm)	PHASE NOISE dBc/Hz SSB at offset frequencies, kHz				TUNING				NON HARMONIC SPURIOUS (dBc)	HARMONICS (dBc)		PULLING pk-pk @12 dB (MHz)	PUSHING (MHz/V)	DC OPERATING POWER		
	Min.	Max.		Typ.	1	10	100	1000	VOLTAGE RANGE (V)	SENSI-TIVITY (MHz/V)	PORT CAP (pF)		3 dB MODULATION BANDWIDTH (MHz)	Typ.			Max.	Typ.	Max.
ZX95-928C+	902	928	+10	-89	-117	-138	-157	0.5	5	18	20	130	-90	-22	-15	1	0.2	12	32

### Maximum Ratings

Operating Temperature	-55°C to 85°C
Storage Temperature	-55°C to 100°C
Absolute Max. Supply Voltage (Vcc)	14V
Absolute Max. Tuning Voltage (Vtune)	7V
All specifications	50 ohm system

Permanent damage may occur if any of these limits are exceeded.



NOTE: When soldering the DC connections, caution must be used to avoid overheating the DC terminals. See Application Note [AN-40-10](#).

### Outline Drawing

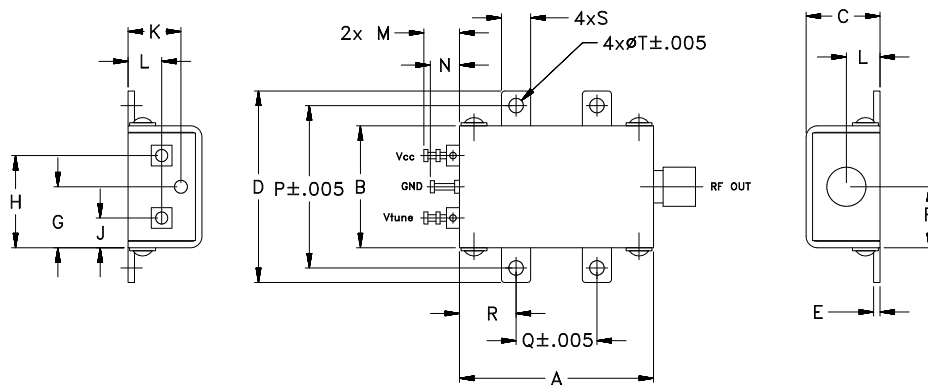

### Outline Dimensions (inch/mm)

A	B	C	D	E	F	G	H	J	K	L	M	N	P	Q	R	S	T	wt.
1.20	.75	.46	1.18	.04	.38	.38	.57	.18	.33	.21	.22	.18	1.00	.50	.35	.18	.106	grams
30.48	19.05	11.68	29.97	1.02	9.65	9.65	14.48	4.57	8.38	5.33	5.59	4.57	25.40	12.70	8.89	4.57	2.69	35.0

#### Notes

- Performance and quality attributes and conditions not expressly stated in this specification document are intended to be excluded and do not form a part of this specification document.
- Electrical specifications and performance data contained in this specification document are based on Mini-Circuit's applicable established test performance criteria and measurement instructions.
- The parts covered by this specification document are subject to Mini-Circuits standard limited warranty and terms and conditions (collectively, "Standard Terms"); Purchasers of this part are entitled to the rights and benefits contained therein. For a full statement of the Standard Terms and the exclusive rights and remedies thereunder, please visit Mini-Circuits' website at [www.minicircuits.com/MCLStore/terms.jsp](http://www.minicircuits.com/MCLStore/terms.jsp)



[www.minicircuits.com](http://www.minicircuits.com) P.O. Box 350166, Brooklyn, NY 11235-0003 (718) 934-4500 sales@minicircuits.com

REV. A  
M152326  
EDR-8303F2  
ZX95-928C+  
RAV  
150923  
Page 1 of 2

# Performance Data & Curves\*

# ZX95-928C+

V TUNE	TUNE SENS (MHz/V)	FREQUENCY (MHz)			POWER OUTPUT (dBm)			Icc (mA)	HARMONICS (dBc)			FREQ. PUSH (MHz/V)	FREQ. PULL (MHz)	PHASE NOISE (dBc/Hz) at offsets				FREQ OFFSET (KHz)	PHASE NOISE at 915 MHz (dBc/Hz)
		-55°C	+25°C	+85°C	-55°C	+25°C	+85°C		F2	F3	F4			1kHz	10kHz	100kHz	1MHz		
0.00	25.07	875.5	872.5	868.0	10.07	9.60	9.15	26.04	-22.6	-31.6	-47.9	0.52	4.47	-84.4	-112.2	-134.3	-153.8	1.0	-88.21
0.50	20.33	887.1	884.3	880.0	10.39	9.86	9.46	26.23	-22.3	-30.6	-46.7	0.36	3.21	-86.7	-115.3	-136.3	-155.0	2.0	-97.01
0.75	19.29	892.2	889.4	885.2	10.44	9.91	9.52	26.26	-22.3	-30.1	-47.0	0.28	2.80	-88.1	-116.3	-137.2	-156.3	3.5	-106.58
1.00	18.68	897.1	894.2	890.0	10.49	9.95	9.56	26.29	-22.3	-29.7	-47.0	0.24	2.44	-89.0	-115.7	-137.4	-156.9	6.0	-111.62
1.25	18.33	901.8	898.8	894.7	10.54	9.99	9.61	26.31	-22.2	-29.3	-47.7	0.21	2.12	-87.6	-116.0	-137.9	-156.7	8.5	-114.16
1.50	18.13	906.4	903.4	899.3	10.59	10.03	9.65	26.34	-22.1	-28.9	-48.3	0.19	1.81	-87.7	-116.5	-137.7	-157.4	10.0	-117.02
1.75	17.99	911.0	908.0	903.8	10.63	10.06	9.69	26.35	-22.1	-28.6	-49.0	0.18	1.51	-89.4	-116.3	-137.8	-156.6	20.8	-124.00
2.00	17.90	915.5	912.5	908.4	10.65	10.08	9.73	26.37	-22.1	-28.4	-48.8	0.17	1.24	-89.1	-116.8	-137.7	-157.0	35.5	-128.47
2.25	17.80	920.0	916.9	912.9	10.66	10.09	9.75	26.38	-22.0	-28.2	-49.4	0.18	1.00	-88.3	-117.0	-138.4	-156.4	60.7	-132.95
2.50	17.76	924.4	921.4	917.3	10.66	10.09	9.76	26.40	-21.9	-27.7	-50.8	0.19	0.88	-88.3	-117.0	-137.8	-156.7	86.7	-136.28
2.75	17.66	928.8	925.8	921.8	10.66	10.07	9.76	26.41	-21.9	-27.4	-52.2	0.20	1.03	-88.0	-116.6	-137.6	-156.6	100.0	-138.02
3.00	17.50	933.2	930.2	926.3	10.64	10.05	9.74	26.42	-21.9	-27.0	-53.7	0.23	1.21	-88.4	-116.3	-137.5	-156.3	148.1	-140.68
3.25	17.30	937.6	934.6	930.7	10.61	10.03	9.73	26.43	-22.0	-26.8	-55.4	0.25	1.43	-87.1	-116.8	-137.5	-156.4	177.0	-142.34
3.50	17.14	941.9	938.9	935.1	10.58	10.00	9.71	26.44	-21.9	-26.8	-58.0	0.27	1.69	-87.6	-116.9	-137.1	-156.9	211.6	-142.96
3.75	17.00	946.1	943.2	939.4	10.53	9.96	9.68	26.44	-21.8	-26.4	-61.9	0.29	1.98	-87.4	-116.1	-137.4	-157.0	302.4	-147.33
4.00	16.72	950.4	947.5	943.7	10.45	9.90	9.64	26.45	-21.9	-25.8	-64.5	0.32	2.28	-88.8	-115.5	-136.9	-156.8	361.5	-147.51
4.25	16.38	954.5	951.7	947.9	10.39	9.84	9.58	26.46	-21.8	-25.6	-66.1	0.34	2.55	-88.6	-115.1	-136.9	-156.3	507.5	-151.42
4.50	16.07	958.6	955.8	952.0	10.32	9.79	9.53	26.46	-21.8	-25.5	-62.0	0.35	2.79	-89.8	-115.4	-136.3	-156.7	606.7	-152.67
4.70	15.81	961.8	959.0	955.2	10.27	9.75	9.50	26.47	-21.7	-25.3	-58.0	0.37	2.97	-88.7	-115.0	-136.3	-156.0	851.6	-155.52
5.00	15.42	966.6	963.7	960.0	10.18	9.68	9.45	26.47	-21.7	-25.1	-52.8	0.38	3.19	-87.7	-115.3	-136.3	-155.0	1000.0	-156.25

\*at 25°C unless mentioned otherwise

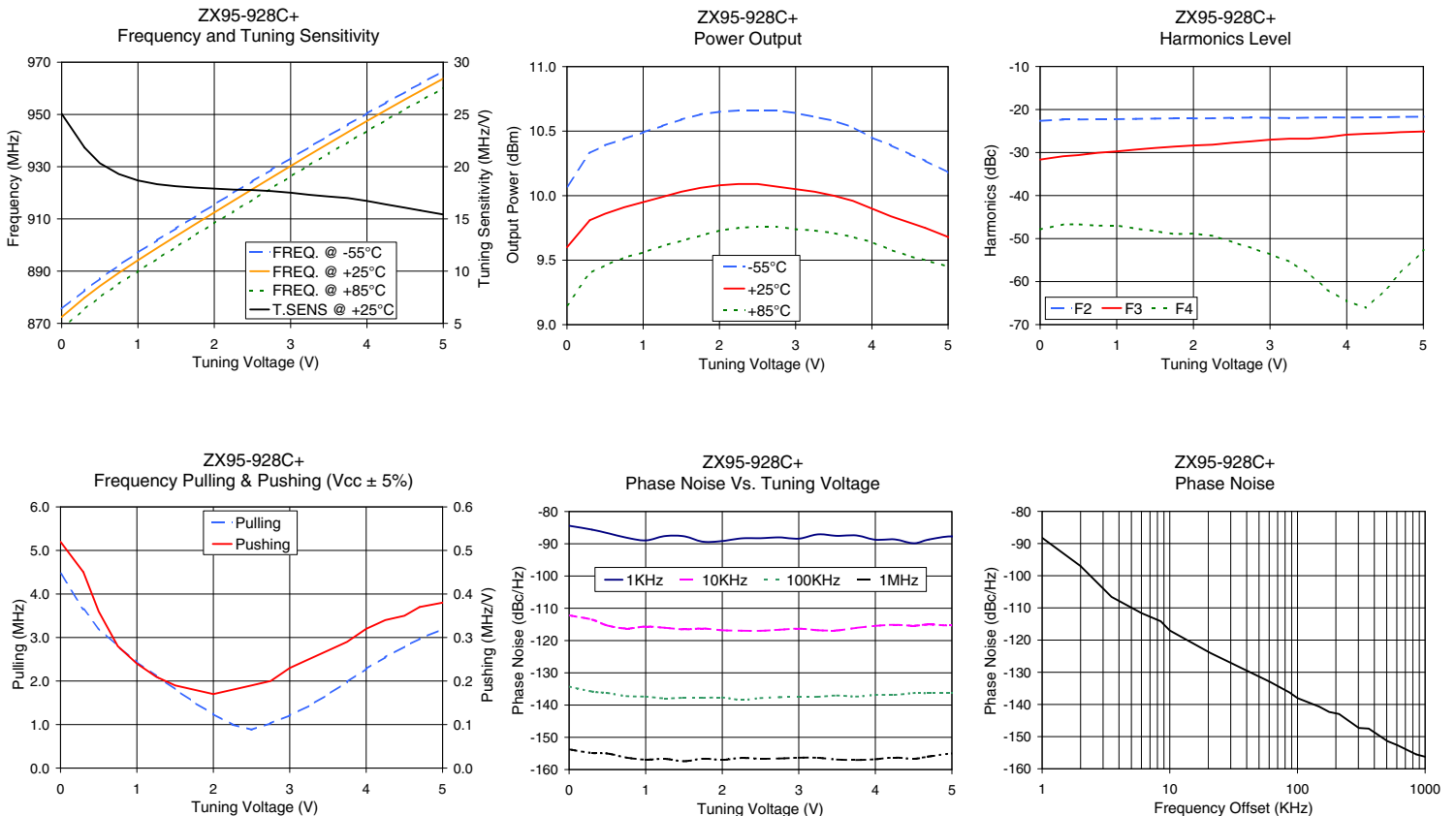

**Notes**

- A. Performance and quality attributes and conditions not expressly stated in this specification document are intended to be excluded and do not form a part of this specification document.
- B. Electrical specifications and performance data contained in this specification document are based on Mini-Circuit's applicable established test performance criteria and measurement instructions.
- C. The parts covered by this specification document are subject to Mini-Circuits standard limited warranty and terms and conditions (collectively, "Standard Terms"); Purchasers of this part are entitled to the rights and benefits contained therein. For a full statement of the Standard Terms and the exclusive rights and remedies thereunder, please visit Mini-Circuits' website at [www.minicircuits.com/MCLStore/terms.jsp](http://www.minicircuits.com/MCLStore/terms.jsp)

