

Coaxial

Voltage Controlled Oscillator

ZX95-1480+

Wide Band 670 to 1480 MHz

Features

- low phase noise
- low pushing
- protected by US patent 6,790,049



CASE STYLE: GB956

Applications

- r & d
- lab
- instrumentation
- wireless communications
- radio link

Connectors	Model
SMA	ZX95-1480-S+

+RoHS Compliant
The +Suffix identifies RoHS Compliance. See our web site for RoHS Compliance methodologies and qualifications

Electrical Specifications

MODEL NO.	FREQ. (MHz)		POWER OUTPUT (dBm)	PHASE NOISE dBc/Hz SSB at offset frequencies, kHz				TUNING					NON HARMONIC SPURIOUS (dBc)	HARMONICS (dBc)		PULLING pk-pk @ 12 dB (MHz)	PUSHING (MHz/V)	DC OPERATING POWER	
								VOLTAGE RANGE (V)	SENSI- TIVITY (MHz/V)	PORT CAP (pF)	3 dB MODULATION BANDWIDTH (MHz)								
											Typ.	Typ.							
ZX95-1480+	Min.	Max.	Typ.	1	10	100	1000	Min.	Max.	Typ.	Typ.	Typ.	Typ.	Typ.	Max.	Typ.	Typ.	Vcc	Current
				-66	-97	-119	-140	0.5	12.5	72-100	84	40	-90	-14	-	3.5	2.5	5	40

Maximum Ratings

Operating Temperature	-55°C to 85°C
Storage Temperature	-55°C to 100°C
Absolute Max. Supply Voltage (Vcc)	6.5V
Absolute Max. Tuning Voltage (Vtune)	14.5V
All specifications	50 ohm system

Permanent damage may occur if any of these limits are exceeded.



NOTE: When soldering the DC connections, caution must be used to avoid overheating the DC terminals. See Application Note [AN-40-10](#).

Outline Drawing

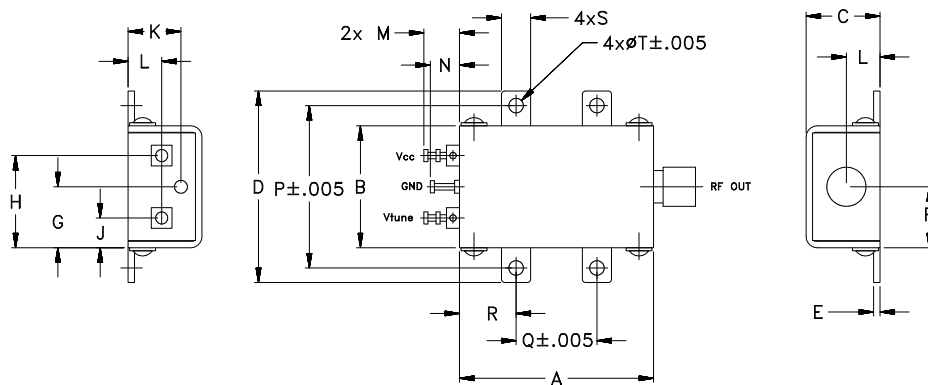

Outline Dimensions (inch/mm)

A	B	C	D	E	F	G	H	J	K	L	M	N	P	Q	R	S	T	wt.
1.20	.75	.46	1.18	.04	.38	.38	.57	.18	.33	.21	.22	.18	1.00	.50	.35	.18	.106	grams
30.48	19.05	11.68	29.97	1.02	9.65	9.65	14.48	4.57	8.38	5.33	5.59	4.57	25.40	12.70	8.89	4.57	2.69	35.0

Notes

- Performance and quality attributes and conditions not expressly stated in this specification document are intended to be excluded and do not form a part of this specification document.
- Electrical specifications and performance data contained in this specification document are based on Mini-Circuit's applicable established test performance criteria and measurement instructions.
- The parts covered by this specification document are subject to Mini-Circuits standard limited warranty and terms and conditions (collectively, "Standard Terms"); Purchasers of this part are entitled to the rights and benefits contained therein. For a full statement of the Standard Terms and the exclusive rights and remedies thereunder, please visit Mini-Circuits' website at www.minicircuits.com/MCLStore/terms.jsp



www.minicircuits.com P.O. Box 350166, Brooklyn, NY 11235-0003 (718) 934-4500 sales@minicircuits.com

REV. B
M164897
EDR-11650
ZX95-1480+
RAV
180312
Page 1 of 2

Performance Data & Curves*

ZX95-1480+

V TUNE	TUNE SENS (MHz/V)	FREQUENCY (MHz)			POWER OUTPUT (dBm)			Icc (mA)	HARMONICS (dBc)			FREQ. PUSH (MHz/V)	FREQ. PULL (MHz)	PHASE NOISE (dBc/Hz) at offsets				FREQ OFFSET (kHz)	PHASE NOISE at 1075 MHz (dBc/Hz)
		-55°C	+25°C	+85°C	-55°C	+25°C	+85°C		F2	F3	F4			1kHz	10kHz	100kHz	1MHz		
0.00	127.66	593.2	574.2	556.8	4.95	5.15	5.04	29.04	-14.2	-18.6	-22.8	1.84	1.11	-69.98	-97.9	-118.4	-138.9	1.0	-71.54
0.50	101.76	655.0	638.1	622.3	5.18	5.43	5.34	29.40	-15.8	-16.7	-23.3	1.22	1.22	-70.96	-99.1	-120.1	-140.5	2.5	-81.75
1.00	90.17	705.6	689.0	673.2	5.41	5.66	5.51	29.62	-17.5	-15.8	-24.6	0.95	0.16	-72.06	-99.4	-120.4	-141.0	4.2	-88.36
2.00	87.36	793.4	776.9	760.8	5.77	5.91	5.64	29.75	-21.1	-15.4	-28.3	0.76	1.72	-71.38	-98.5	-119.6	-140.5	7.2	-94.80
3.00	82.84	883.5	863.3	845.3	6.26	6.13	5.74	30.08	-22.9	-15.1	-31.4	1.00	3.00	-73.58	-98.3	-119.5	-140.4	10.0	-98.59
4.00	83.82	966.9	945.7	927.8	6.47	6.15	5.69	30.43	-23.7	-15.2	-34.4	1.38	3.09	-71.71	-97.7	-119.5	-140.6	12.1	-100.06
4.50	84.77	1008.1	987.6	970.5	6.50	6.08	5.57	30.51	-23.1	-15.5	-35.4	1.65	1.72	-72.97	-98.0	-119.7	-140.7	23.9	-107.03
5.00	85.92	1050.4	1030.0	1013.2	6.40	5.99	5.47	30.47	-23.5	-16.3	-35.9	2.05	2.31	-71.22	-98.6	-119.7	-140.8	40.1	-112.13
5.74	87.06	1113.7	1094.0	1078.6	6.19	5.74	5.20	30.35	-22.7	-17.8	-34.3	2.57	2.03	-71.54	-98.6	-120.2	-141.2	66.1	-116.71
6.00	86.39	1135.9	1116.8	1101.7	6.12	5.66	5.11	30.32	-22.3	-18.3	-33.3	2.72	0.19	-72.51	-98.8	-120.4	-141.5	79.0	-120.15
6.50	88.20	1179.5	1160.0	1145.8	5.99	5.51	4.92	30.14	-21.8	-19.6	-33.2	3.03	3.63	-70.56	-98.6	-120.5	-141.4	100.0	-121.37
7.00	84.48	1222.0	1204.1	1190.5	5.85	5.37	4.76	30.09	-21.6	-21.1	-32.0	3.12	2.55	-71.29	-99.6	-121.2	-142.2	155.7	-124.49
8.00	79.83	1306.9	1289.5	1276.6	5.60	5.09	4.44	29.86	-21.1	-23.9	-32.1	3.27	4.17	-71.21	-98.9	-121.0	-142.2	182.8	-125.92
8.50	79.22	1346.4	1329.4	1317.3	5.49	5.02	4.32	29.78	-20.2	-25.2	-32.3	3.13	0.61	-71.54	-99.2	-121.3	-142.4	218.5	-127.52
9.00	74.31	1386.0	1369.0	1356.6	5.37	4.89	4.17	29.65	-19.8	-26.3	-32.8	3.18	4.50	-69.67	-98.4	-120.6	-141.9	306.7	-130.56
10.00	67.95	1457.6	1441.6	1430.0	5.09	4.63	3.87	29.48	-18.7	-25.1	-32.9	2.96	4.76	-69.30	-98.2	-120.7	-141.7	360.2	-131.98
10.50	65.25	1491.4	1475.5	1464.3	4.97	4.48	3.69	29.40	-18.3	-24.5	-33.9	2.88	0.26	-71.50	-98.1	-120.5	-141.7	505.5	-135.12
11.00	62.07	1523.7	1508.2	1497.1	4.84	4.36	3.54	29.31	-18.0	-23.5	-34.5	2.85	4.40	-70.26	-98.5	-120.3	-141.7	604.2	-136.73
12.00	56.87	1582.9	1568.1	1557.9	4.54	4.08	3.20	29.15	-17.5	-22.1	-34.8	2.66	3.26	-69.65	-97.9	-120.4	-141.7	995.8	-141.33
12.50	54.42	1611.4	1596.5	1586.2	4.34	3.88	2.97	29.05	-17.0	-21.9	-35.7	2.68	4.42	-69.55	-97.8	-120.1	-141.4	1000.0	-141.21

*at 25°C unless mentioned otherwise

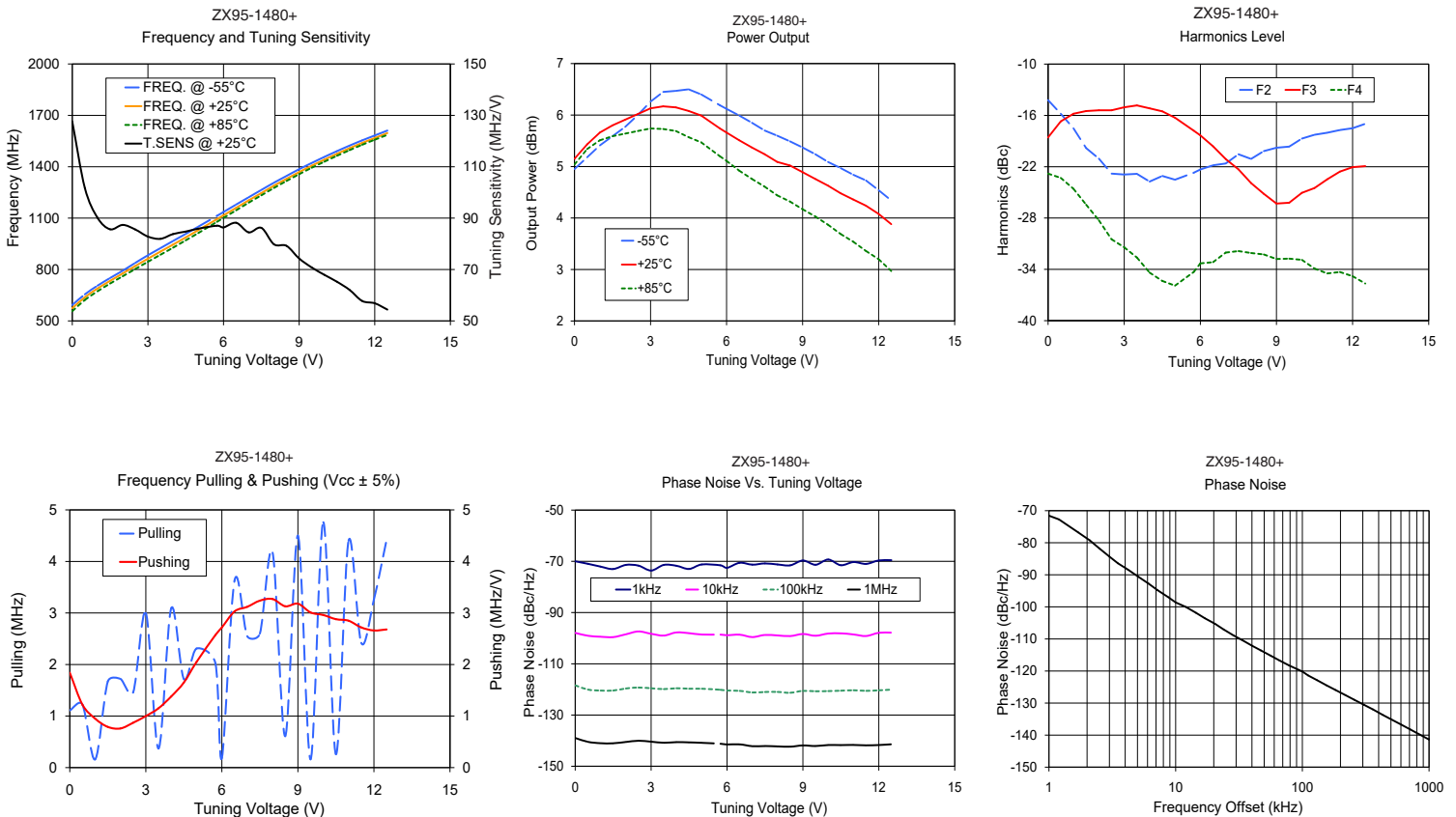

Notes

- Performance and quality attributes and conditions not expressly stated in this specification document are intended to be excluded and do not form a part of this specification document.
- Electrical specifications and performance data contained in this specification document are based on Mini-Circuit's applicable established test performance criteria and measurement instructions.
- The parts covered by this specification document are subject to Mini-Circuits standard limited warranty and terms and conditions (collectively, "Standard Terms"); Purchasers of this part are entitled to the rights and benefits contained therein. For a full statement of the Standard Terms and the exclusive rights and remedies thereunder, please visit Mini-Circuits' website at www.minicircuits.com/MCLStore/terms.jsp

