

Surface Mount

Voltage Controlled Oscillator

SOS-1884-119+

5V Tuning for PLL IC's 1834 to 1884 MHz

Features

- low power output, -10dBm typ.
- linear tuning characteristics
- low phase noise
- low pushing & pulling
- small size 0.3" x 0.3"
- aqueous washable



CASE STYLE: FZ802

Applications

- wireless communications
- tetra base station

+RoHS Compliant
The +Suffix identifies RoHS Compliance. See our web site for RoHS Compliance methodologies and qualifications

Electrical Specifications

MODEL NO.	FREQ. (MHz)		POWER OUTPUT (dBm)	PHASE NOISE dBc/Hz SSB at offset frequencies, kHz				TUNING				NON HARMONIC SPURIOUS (dBc)	HARMONICS (dBc)		PULLING pk-pk @ 12 dB (MHz)	PUSHING (MHz/V)	DC OPERATING POWER		
	Min.	Max.		Typ.	1	10	100	1000	VOLTAGE RANGE (V)	SENSI-TIVITY (MHz/V)	PORT CAP (pF)		3 dB MODULATION BANDWIDTH (MHz)	Typ.			Max.	Vcc (volts)	Current (mA)
SOS-1884-119+	1834	1884	-10	-80	-104	-125	-145	0.5	5	21-24	17	85	-90	-18	-	0.15	1.5	4.5	16

Pin Connections

RF OUT	8
VCC	11
V-TUNE	1
GROUND	2,3,4,5,6,7,9,10,12

Maximum Ratings

Operating Temperature	-55°C to 85°C
Storage Temperature	-55°C to 100°C
Absolute Max. Supply Voltage (Vcc)	7V
Absolute Max. Tuning Voltage (Vtune)	7V
All specifications	50 ohm system

Permanent damage may occur if any of these limits are exceeded.

Outline Drawing

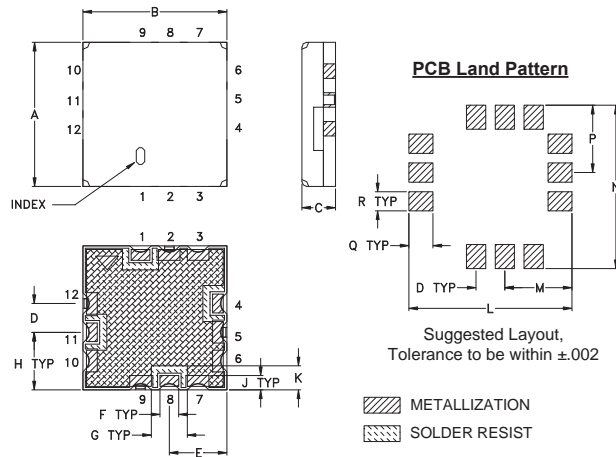

Demo Board MCL P/N: TB-271 Suggested PCB Layout (PL-143)

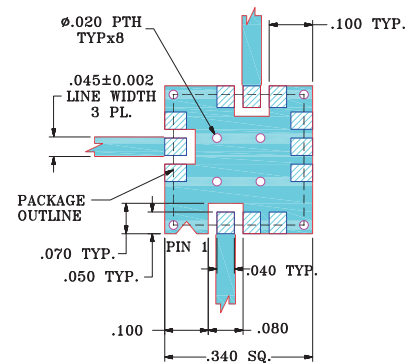

- NOTE:
1. TRACE WIDTH IS SHOWN FOR FR4 WITH DIELECTRIC THICKNESS .025"±.002"; COPPER: 1/2 OZ. EACH SIDE. FOR OTHER MATERIALS TRACE WIDTH MAY NEED TO BE MODIFIED.
 2. BOTTOM SIDE OF THE PCB IS CONTINUOUS GROUND PLANE.
- DENOTES PCB COPPER LAYOUT WITH SMOBC (SOLDER MASK OVER BARE COPPER)
 - DENOTES COPPER LAND PATTERN FREE OF SOLDER MASK

Outline Dimensions (inch/mm)

A	B	C	D	E	F	G	H	J	K	L	M	N	P	Q	R	wt.
.300	.300	.070	.060	.120	.039	.075	.120	.030	.050	.340	.140	.340	.140	.050	.040	grams
7.62	7.62	1.78	1.52	3.05	0.99	1.91	3.05	0.76	1.27	8.64	3.56	8.64	3.56	1.27	1.02	.25

Notes

- A. Performance and quality attributes and conditions not expressly stated in this specification document are intended to be excluded and do not form a part of this specification document.
- B. Electrical specifications and performance data contained in this specification document are based on Mini-Circuit's applicable established test performance criteria and measurement instructions.
- C. The parts covered by this specification document are subject to Mini-Circuits standard limited warranty and terms and conditions (collectively, "Standard Terms"); Purchasers of this part are entitled to the rights and benefits contained therein. For a full statement of the Standard Terms and the exclusive rights and remedies thereunder, please visit Mini-Circuits' website at www.minicircuits.com/MCLStore/terms.jsp



www.minicircuits.com P.O. Box 350166, Brooklyn, NY 11235-0003 (718) 934-4500 sales@minicircuits.com

REV. A
M151108
EDR-9465F1
SOS-1884-119+
RAV
150512
Page 1 of 2

Performance Data & Curves*

SOS-1884-119+

V TUNE	TUNE SENS (MHz/V)	FREQUENCY (MHz)			POWER OUTPUT (dBm)			Icc (mA)	HARMONICS (dBc)			FREQ. PUSH (MHz/V)	FREQ. PULL (MHz)	PHASE NOISE (dBc/Hz) at offsets				FREQ OFFSET (KHz)	PHASE NOISE at 1862 MHz (dBc/Hz)
		-55°C	+25°C	+85°C	-55°C	+25°C	+85°C		F2	F3	F4			1kHz	10kHz	100kHz	1MHz		
0.00	24.37	1819.1	1808.1	1802.1	-11.10	-10.61	-10.35	11.06	-15.5	-34.4	-31.0	1.12	0.21	-81.8	-104.2	-124.6	-146.1	1.0	-82.10
0.50	21.75	1830.6	1819.9	1814.2	-11.01	-10.49	-10.24	11.11	-15.6	-33.3	-31.4	1.21	0.22	-81.3	-104.3	-124.8	-145.4	2.1	-89.41
0.75	21.28	1836.0	1825.3	1819.6	-10.97	-10.43	-10.17	11.14	-15.9	-33.7	-30.4	1.25	0.20	-81.5	-104.2	-124.8	-144.4	3.5	-95.11
1.00	21.05	1841.3	1830.7	1824.9	-10.91	-10.40	-10.10	11.16	-16.1	-34.0	-31.3	1.29	0.19	-82.7	-104.6	-124.9	-144.8	6.1	-99.97
1.25	21.09	1846.6	1835.9	1830.1	-10.84	-10.35	-10.07	11.18	-16.5	-34.4	-31.0	1.31	0.17	-81.2	-104.5	-124.8	-143.7	8.7	-103.31
1.50	21.19	1851.9	1841.2	1835.4	-10.78	-10.30	-10.02	11.20	-17.0	-34.1	-28.9	1.35	0.14	-81.2	-104.0	-124.9	-144.8	10.0	-104.56
1.75	21.45	1857.3	1846.5	1840.6	-10.74	-10.21	-9.96	11.23	-16.8	-34.5	-29.5	1.38	0.11	-82.0	-104.6	-125.0	-144.6	21.1	-111.33
2.00	21.87	1862.7	1851.9	1845.9	-10.71	-10.12	-9.89	11.26	-16.2	-34.9	-30.3	1.43	0.08	-80.5	-104.7	-125.1	-144.9	36.1	-116.00
2.25	22.23	1868.3	1857.3	1851.3	-10.70	-10.06	-9.80	11.28	-16.3	-34.8	-29.7	1.45	0.06	-81.3	-104.7	-125.2	-144.1	60.5	-120.78
2.50	22.61	1874.0	1862.9	1856.7	-10.70	-10.02	-9.72	11.30	-16.8	-34.9	-29.0	1.48	0.07	-80.7	-105.0	-125.3	-144.8	84.9	-123.33
2.75	22.90	1879.7	1868.5	1862.3	-10.68	-10.00	-9.65	11.34	-17.2	-34.8	-28.9	1.52	0.12	-80.8	-104.7	-125.3	-144.3	100.0	-124.77
3.00	22.93	1885.4	1874.3	1867.9	-10.65	-9.99	-9.61	11.36	-17.7	-35.8	-29.1	1.56	0.16	-81.5	-104.7	-125.2	-144.4	142.4	-127.91
3.25	22.98	1891.2	1880.0	1873.6	-10.62	-9.98	-9.60	11.40	-18.4	-36.5	-28.2	1.57	0.18	-80.5	-104.9	-125.3	-144.4	167.2	-129.41
3.50	22.89	1897.0	1885.7	1879.3	-10.59	-9.95	-9.57	11.43	-18.5	-36.2	-28.0	1.57	0.19	-82.1	-104.9	-125.3	-144.6	199.9	-130.77
3.75	22.84	1902.8	1891.4	1885.0	-10.54	-9.92	-9.56	11.47	-17.8	-36.1	-26.6	1.60	0.20	-80.8	-105.2	-125.5	-144.3	280.6	-133.80
4.00	22.59	1908.6	1897.2	1890.7	-10.47	-9.89	-9.54	11.50	-17.8	-36.5	-26.5	1.63	0.20	-80.8	-105.2	-125.6	-144.4	329.4	-135.26
4.25	22.29	1914.2	1902.8	1896.2	-10.41	-9.85	-9.50	11.53	-17.9	-37.3	-27.2	1.63	0.20	-80.8	-105.2	-125.6	-144.7	462.4	-138.00
4.50	21.92	1919.8	1908.4	1901.8	-10.35	-9.77	-9.46	11.57	-18.0	-36.9	-26.2	1.65	0.18	-81.5	-105.2	-125.7	-144.1	552.7	-139.47
4.75	21.35	1925.3	1913.9	1907.2	-10.31	-9.69	-9.39	11.61	-18.6	-37.1	-26.1	1.67	0.16	-81.7	-105.3	-125.7	-144.9	910.8	-143.21
5.00	20.87	1930.6	1919.2	1912.6	-10.26	-9.62	-9.31	11.64	-19.5	-37.8	-26.5	1.69	0.14	-81.5	-105.2	-125.6	-144.8	1000.0	-143.90

*at 25°C unless mentioned otherwise

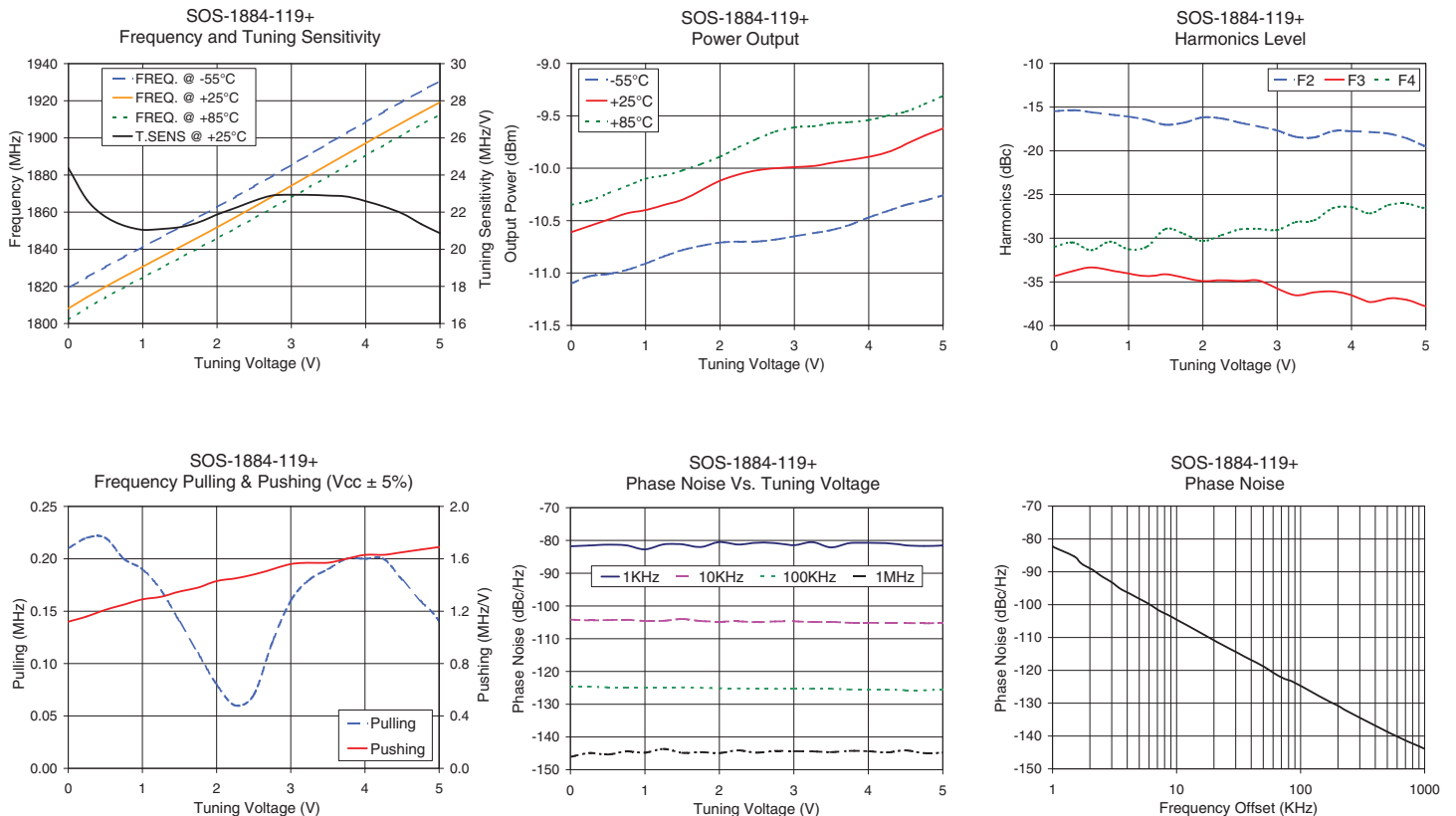

Notes

- A. Performance and quality attributes and conditions not expressly stated in this specification document are intended to be excluded and do not form a part of this specification document.
- B. Electrical specifications and performance data contained in this specification document are based on Mini-Circuit's applicable established test performance criteria and measurement instructions.
- C. The parts covered by this specification document are subject to Mini-Circuits standard limited warranty and terms and conditions (collectively, "Standard Terms"); Purchasers of this part are entitled to the rights and benefits contained therein. For a full statement of the Standard Terms and the exclusive rights and remedies thereunder, please visit Mini-Circuits' website at www.minicircuits.com/MCLStore/terms.jsp

