

NON-CATALOG

Surface Mount

Voltage Controlled Oscillator

SOS-1230-119+

5V Tuning for PLL IC's 1140 to 1230 MHz

Features

- Low phase noise
- Low pushing
- Low pulling
- Aqueous washable

Applications

- Wireless communications
- Defense system
- Radar & navigation system
- GPS



CASE STYLE: FZ990

+RoHS Compliant

The +Suffix identifies RoHS Compliance. See our web site for RoHS Compliance methodologies and qualifications

Electrical Specifications

MODEL NO.	FREQ. (MHz)		POWER OUTPUT (dBm)	PHASE NOISE dBc/Hz SSB at offset frequencies, kHz				TUNING					NON HARMONIC SPURIOUS (dBc)	HARMONICS (dBc)		PULLING pk-pk @ 12 dB (MHz)	PUSHING (MHz/V)	DC OPERATING POWER		
	Min.	Max.		Typ.	1	10	100	1000	VOLTAGE RANGE (V)	SENSI- TIVITY (MHz/V)	PORT CAP (pF)	3 dB MODULATION BANDWIDTH (MHz)		Typ.	Typ.			Typ.	Max.	Vcc (volts)
SOS-1230-119+	1140	1230	+0.5	-76	-104	-125	-145	0.5	3	61	-97	24	90	-90	-17	-10	0.7	0.4	8	20

Pin Connections

RF OUT	8
VCC	11
V-TUNE	1
GROUND	2,3,4,5,6,7,9,10,12

Maximum Ratings

Operating Temperature	-55°C to 85°C
Storage Temperature	-55°C to 100°C
Absolute Max. Supply Voltage (Vcc)	10V
Absolute Max. Tuning Voltage (Vtune)	5V
All specifications	50 ohm system

Permanent damage may occur if any of these limits are exceeded.

Outline Drawing

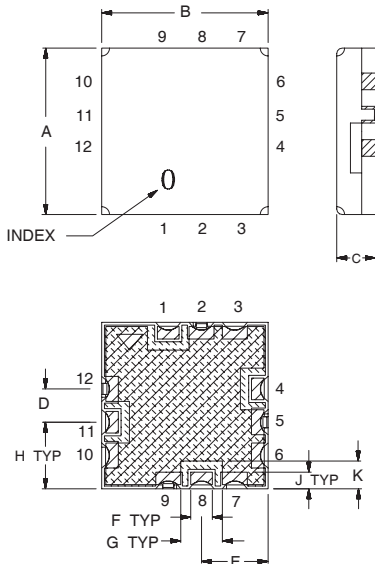

PCB Land Pattern

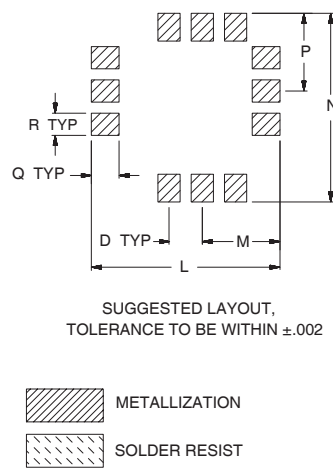

Demo Board MCL P/N: TB-271 Suggested PCB Layout (PL-143)

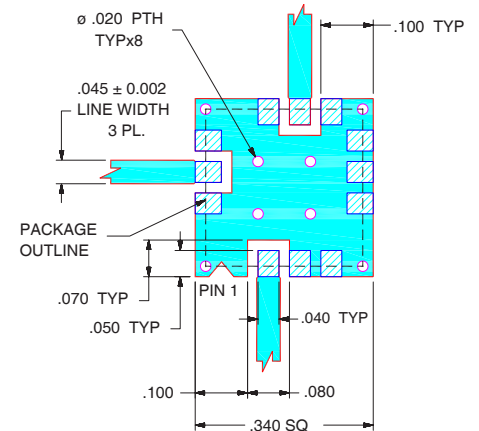

NOTE:

1. TRACE WIDTH IS SHOWN FOR RF4 WITH DIELECTRIC THICKNESS .025" ± .002"; COPPER: 1/2 OZ. EACH SIDE. FOR OTHER MATERIALS TRACE WIDTH MAY NEED TO BE MODIFIED.
 2. BOTTOM SIDE OF THE PCB IS CONTINUOUS GROUND PLANE.
-

Outline Dimensions (inch/mm)

A	B	C	D	E	F	G	H	J	K	L	M	N	P	Q	R	wt. grams
.300	.300	.100	.060	.120	.039	.075	.120	.030	.050	.340	.140	.340	.140	.050	.040	0.25
7.62	7.62	2.54	1.52	3.05	0.99	1.91	3.05	0.76	1.27	8.64	3.56	8.64	3.56	1.27	1.02	

Notes

- A. Performance and quality attributes and conditions not expressly stated in this specification document are intended to be excluded and do not form a part of this specification document.
- B. Electrical specifications and performance data contained in this specification document are based on Mini-Circuit's applicable established test performance criteria and measurement instructions.
- C. The parts covered by this specification document are subject to Mini-Circuits standard limited warranty and terms and conditions (collectively, "Standard Terms"); Purchasers of this part are entitled to the rights and benefits contained therein. For a full statement of the Standard Terms and the exclusive rights and remedies thereunder, please visit Mini-Circuits' website at www.minicircuits.com/MCLStore/terms.jsp



www.minicircuits.com P.O. Box 350166, Brooklyn, NY 11235-0003 (718) 934-4500 sales@minicircuits.com

REV. B
M157541
EDR-10004F1
SOS-1230-119+
RAV
170605
Page 1 of 2

NON-CATALOG

Performance Data & Curves*

SOS-1230-119+

V TUNE	TUNE SENS (MHz/V)	FREQUENCY (MHz)			POWER OUTPUT (dBm)			Icc (mA)	HARMONICS (dBc)			FREQ. PUSH (MHz/V)	FREQ. PULL (MHz)	PHASE NOISE (dBc/Hz) at offsets				FREQ OFFSET (KHz)	PHASE NOISE at 1205 MHz (dBc/Hz)
		-55°C	+25°C	+85°C	-55°C	+25°C	+85°C		F2	F3	F4			1kHz	10kHz	100kHz	1MHz		
0.00	61.17	1097.6	1088.9	1082.4	0.44	0.49	-0.11	14.10	-15.3	-36.8	-36.5	0.05	0.03	-78.5	-104.2	-125.2	-145.3	1.0	-76.46
0.25	59.99	1112.6	1104.1	1097.9	0.33	0.42	-0.10	14.12	-15.2	-36.1	-37.3	0.01	0.43	-78.7	-104.3	-125.0	-145.3	3.5	-93.66
0.50	63.79	1128.4	1119.1	1113.3	0.37	0.28	-0.34	14.12	-15.4	-34.8	-38.4	0.01	0.88	-78.2	-103.6	-124.8	-144.5	5.0	-97.48
0.75	61.46	1144.0	1135.1	1129.1	0.53	0.43	-0.26	14.14	-15.7	-34.4	-40.2	0.02	0.96	-76.9	-104.5	-124.8	-144.9	10.0	-104.20
1.00	63.86	1159.5	1150.5	1144.1	0.51	0.54	-0.01	14.18	-16.1	-33.7	-41.9	0.06	0.39	-76.1	-104.6	-125.7	-145.7	35.5	-116.31
1.25	68.37	1175.8	1166.4	1159.9	0.40	0.45	-0.07	14.19	-16.1	-32.6	-43.7	0.10	0.56	-76.3	-104.3	-125.6	-145.6	50.7	-119.56
1.50	77.07	1193.3	1183.5	1177.1	0.28	0.27	-0.37	14.17	-16.8	-31.2	-44.6	0.13	0.92	-77.0	-104.0	-125.4	-145.6	100.0	-125.43
1.75	85.08	1213.3	1202.8	1196.5	0.42	0.12	-0.71	14.16	-17.4	-30.4	-43.1	0.07	0.32	-75.2	-103.7	-125.3	-145.1	142.9	-128.65
2.00	94.63	1234.5	1224.1	1217.5	0.37	0.05	-0.79	14.15	-18.3	-29.4	-40.5	0.03	0.33	-74.7	-103.5	-125.5	-145.1	235.6	-133.14
2.25	106.85	1257.8	1247.7	1240.8	-0.02	-0.51	-1.23	14.14	-19.6	-28.2	-37.1	0.09	0.61	-72.9	-102.8	-124.6	-144.6	330.7	-136.02
2.50	113.88	1285.1	1274.4	1266.6	-0.75	-1.15	-1.72	14.12	-22.0	-27.9	-35.7	0.23	0.09	-74.8	-102.2	-123.6	-143.6	464.2	-138.91
2.80	118.20	1320.6	1308.8	1300.1	-1.77	-1.87	-2.22	14.11	-25.4	-26.3	-33.8	0.61	0.65	-73.3	-101.6	-123.5	-143.2	914.6	-144.69
3.00	117.34	1344.7	1332.5	1323.3	-2.29	-2.36	-2.61	14.11	-28.4	-25.9	-32.8	1.02	0.09	-73.9	-100.9	-123.2	-142.9	1000.0	-145.53

*at 25°C unless mentioned otherwise

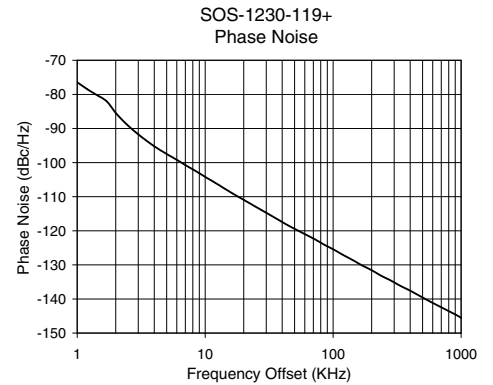
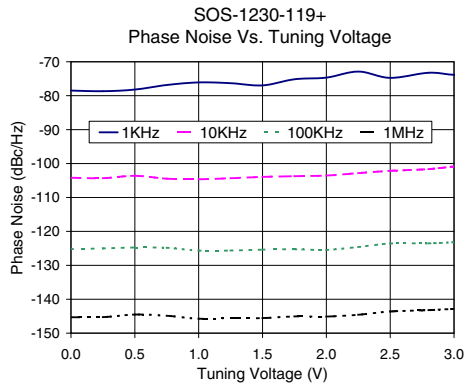
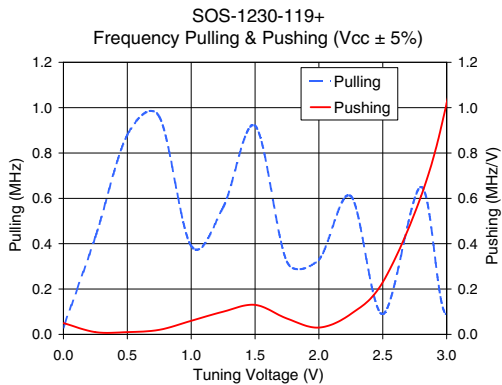
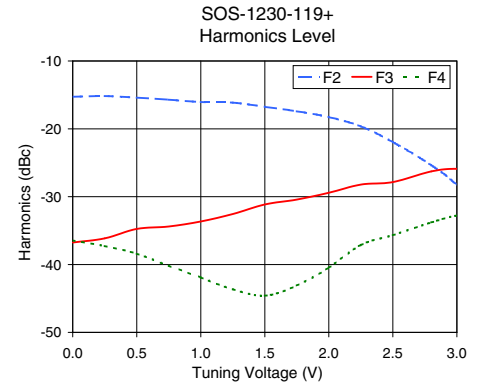
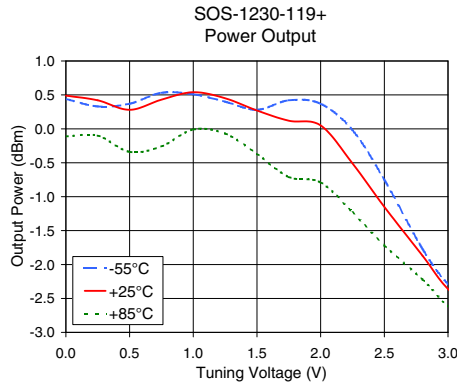
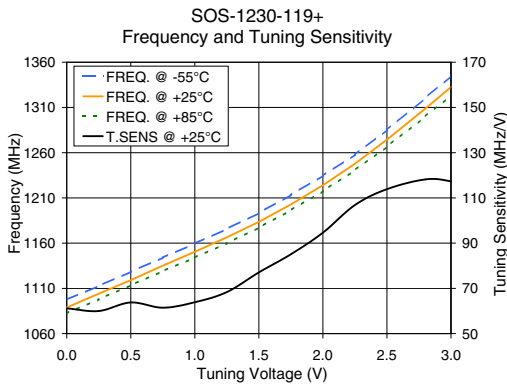

Notes

- A. Performance and quality attributes and conditions not expressly stated in this specification document are intended to be excluded and do not form a part of this specification document.
- B. Electrical specifications and performance data contained in this specification document are based on Mini-Circuit's applicable established test performance criteria and measurement instructions.
- C. The parts covered by this specification document are subject to Mini-Circuits standard limited warranty and terms and conditions (collectively, "Standard Terms"); Purchasers of this part are entitled to the rights and benefits contained therein. For a full statement of the Standard Terms and the exclusive rights and remedies thereunder, please visit Mini-Circuits' website at www.minicircuits.com/MCLStore/terms.jsp

