

# Low Pass Filter

## SALF-116

50Ω DC to 116 MHz

### Maximum Ratings

Operating Temperature	-40°C to 85°C
Storage Temperature	-55°C to 100°C
Power Input	0.5W max.

Permanent damage may occur if any of these limits are exceeded.

### Pin Connections

INPUT	1
OUTPUT	8
GROUND	2,3,4,5,6,7

### Outline Drawing

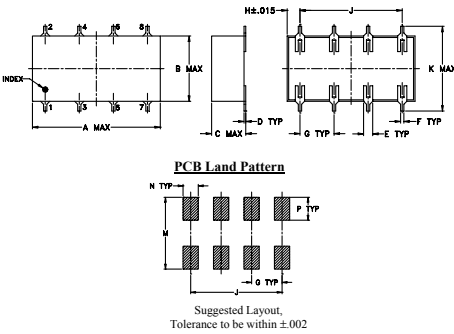

### Outline Dimensions (inch)

A	B	C	D	E	F	G
.75	.38	.20	.010	.050	.020	.200
19.05	9.65	5.08	0.25	1.27	0.51	5.08
H	J	K	M	N	P	wt
.075	.600	.450	.470	.100	.150	grams
1.91	15.24	11.43	11.94	2.54	3.81	1.6

### Demo Board MCL P/N: TB-187+ Suggested PCB Layout (PL-049)

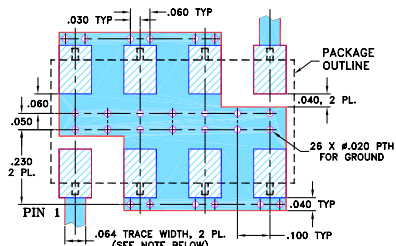

- NOTES:
- TRACE WIDTH IS SHOWN FOR ROGERS RO4350B WITH DIELECTRIC THICKNESS .030" ± .002"; COPPER: 1/2 OZ. EACH SIDE. FOR OTHER MATERIALS TRACE WIDTH MAY NEED TO BE MODIFIED.
  - BOTTOM SIDE OF THE PCB IS CONTINUOUS GROUND PLANE.
- DENOTES PCB COPPER LAYOUT WITH SMOBC (SOLDER MASK OVER BARE COPPER)
- ▨ DENOTES COPPER LAND PATTERN FREE OF SOLDER MASK

### Notes

- Performance and quality attributes and conditions not expressly stated in this specification document are intended to be excluded and do not form a part of this specification document.
- Electrical specifications and performance data contained in this specification document are based on Mini-Circuit's applicable established test performance criteria and measurement instructions.
- The parts covered by this specification document are subject to Mini-Circuits standard limited warranty and terms and conditions (collectively, "Standard Terms"); Purchasers of this part are entitled to the rights and benefits contained therein. For a full statement of the Standard Terms and the exclusive rights and remedies thereunder, please visit Mini-Circuits' website at [www.minicircuits.com/MCLStore/terms.jsp](http://www.minicircuits.com/MCLStore/terms.jsp)

### Features

- 7-section elliptic function
- excellent rejection

### Applications

- defense communications
- receivers/transmitters
- harmonic rejection of VCOs



CASE STYLE: YY101

### Electrical Specifications

Parameter	F#	Frequency (MHz)	Min.	Typ.	Max.	Unit	
Pass Band	Insertion Loss	DC-F1	DC-116	—	—	1.0	dB
	Freq. Cut-Off	F2	142	—	3.0	—	dB
	VSWR	DC-F1	DC-116	—	1.3	—	:1
Stop Band	Rejection Loss	F3-F4	182-220	20	—	—	dB
		F4-F5	220-825	40	—	—	dB
	VSWR	F3-F5	182-825	—	18	—	:1

### Typical Frequency Response

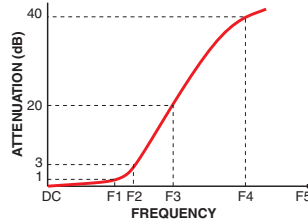

### Electrical Schematic

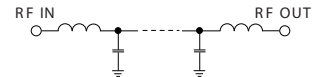

### Typical Performance Data

Frequency (MHz)	Insertion Loss (dB)		Return Loss (dB)
	$\bar{x}$	$\sigma$	
1.00	0.03	0.00	47.20
20.00	0.10	0.00	35.44
50.00	0.19	0.00	24.04
100.00	0.37	0.00	32.44
116.00	0.54	0.01	18.55
142.00	2.41	0.24	7.34
170.00	21.20	0.50	0.42
182.00	29.28	0.50	0.27
205.00	43.25	0.60	0.20
220.00	50.74	0.62	0.19
280.00	55.38	0.32	0.18
380.00	51.16	0.40	0.21
500.00	49.70	0.49	0.21
600.00	50.21	0.59	0.23
700.00	54.82	1.02	0.23
825.00	50.82	1.12	0.22
850.00	46.29	0.96	0.25
1000.00	23.73	2.39	0.39
1500.00	28.01	1.01	0.34
2000.00	29.12	1.29	0.55

SALF-116  
INSERTION LOSS

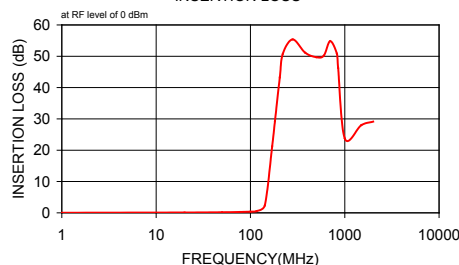

SALF-116  
RETURN LOSS

