

NON-CATALOG

Low Phase Noise

Voltage Controlled Oscillator

ROS-680+

5V Tuning for PLL IC's 650 to 680 MHz

Features

- linear tuning characteristics
- low phase noise
- low pushing
- low pulling
- 0.5-5V tuning voltage range
- aqueous washable

Applications

- PLL circuitry
- frequency synthesizers
- wireless microphones



CASE STYLE: CK605

+RoHS Compliant

The +Suffix identifies RoHS Compliance. See our web site for RoHS Compliance methodologies and qualifications

Electrical Specifications

MODEL NO.	FREQ. (MHz)		POWER OUTPUT (dBm)	PHASE NOISE dBc/Hz SSB at offset frequencies, KHz				TUNING				NON HARMONIC SPURIOUS (dBc)	HARMONICS (dBc)		PULLING pk-pk @12 dB (MHz)	PUSHING (MHz/V)	DC OPERATING POWER		
	Min.	Max.		Typ.	1	10	100	1000	VOLTAGE RANGE (V)	SENSI-TIVITY (MHz/V)	PORT CAP (pF)		3 dB MODULATION BANDWIDTH (MHz)	Typ.			Max.	Vcc	Current (mA)
ROS-680+	650	680	+0.5	-91	-114	-134	-154	0.5	5	11-12	70	50	-90	-24	-16	0.3	0.2	5	18

Pin Connections

RF OUT	10
VCC	14
V-TUNE	2
GROUND	1,3,4,5,6,7,8,9,11,12,13,15,16

Maximum Ratings

Operating Temperature	-55°C to 85°C
Storage Temperature	-55°C to 100°C
Absolute Max. Supply Voltage (Vcc)	7V
Absolute Max. Tuning Voltage (Vtune)	7V
All specifications	50 ohm system

Permanent damage may occur if any of these limits are exceeded.

Outline Drawing

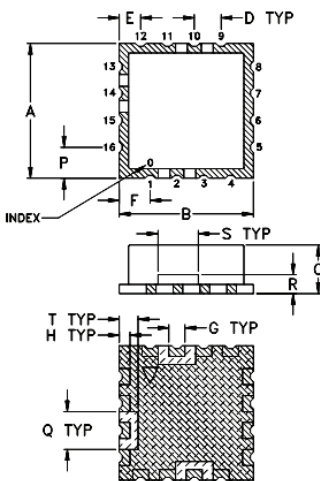

PCB Land Pattern

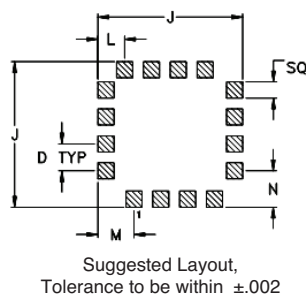

Demo Board MCL P/N: TB-10 Suggested PCB Layout (PL-012)

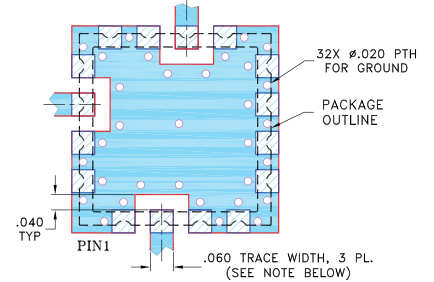

NOTES:

1. TRACE WIDTH IS SHOWN FOR FR4 WITH DIELECTRIC THICKNESS .030" ± .002"; COPPER: 1/2 OZ. EACH SIDE. FOR OTHER MATERIALS TRACE WIDTH MAY NEED TO BE MODIFIED.
 2. BOTTOM SIDE OF THE BOTTOM IS CONTINUOUS GROUND PLANE.
- DENOTES PCB COPPER LAYOUT WITH SMOBC (SOLDER MASK OVER BARE COPPER)
 DENOTES COPPER LAND PATTERN FREE OF SOLDER MASK

Outline Dimensions (inch/mm)

A	B	C	D	E	F	G	H	J	K	L	M	N	P	Q	R	S	T	wt.
.500	.500	.180	.100	.080	.115	.060	.040	.540	.100	.135	.135	.115	.140	.070	.150	.070	.070	grams
12.70	12.70	4.57	2.54	2.03	2.92	1.52	1.02	13.72	1.52	2.54	3.43	3.43	2.92	3.56	1.78	3.81	1.78	1.0



For detailed performance specs & shopping online see web site

P.O. Box 350166, Brooklyn, New York 11235-0003 (718) 934-4500 Fax (718) 332-4661 The Design Engineers Search Engine Provides ACTUAL Data Instantly at minicircuits.com

Notes: 1. Performance and quality attributes and conditions not expressly stated in this specification sheet are intended to be excluded and do not form a part of this specification sheet. 2. Electrical specifications and performance data contained herein are based on Mini-Circuit's applicable established test performance criteria and measurement instructions. 3. The parts covered by this specification sheet are subject to Mini-Circuits standard limited warranty and terms and conditions (collectively, "Standard Terms"); Purchasers of this part are entitled to the rights and benefits contained therein. For a full statement of the Standard Terms and the exclusive rights and remedies thereunder, please visit Mini-Circuits' website at www.minicircuits.com/MCLStore/terms.jsp.

REV. A
M137599
EDR-7747/17
ROS-680+
RAV
120719
Page 1 of 2

NON-CATALOG

Performance Data & Curves*

ROS-680+

V TUNE	TUNE SENS (MHz/V)	FREQUENCY (MHz)			POWER OUTPUT (dBm)			Icc (mA)	HARMONICS (dBc)			FREQ. PUSH (MHz/V)	FREQ. PULL (MHz)	PHASE NOISE (dBc/Hz) at offsets				FREQ OFFSET (KHz)	PHASE NOISE at 652 MHz (dBc/Hz)
		-55°C	+25°C	+85°C	-55°C	+25°C	+85°C		F2	F3	F4			1kHz	10kHz	100kHz	1MHz		
0.00	13.06	637.3	634.2	631.6	-0.43	0.19	0.39	12.87	-24.2	-30.5	-32.2	0.00	0.12	-90.8	-114.5	-134.5	-151.6	1.0	-90.86
0.50	11.52	643.4	640.3	637.9	-0.38	0.25	0.46	12.91	-24.4	-30.5	-31.9	0.08	0.14	-90.1	-113.5	-134.2	-152.6	2.0	-98.49
0.75	11.01	646.2	643.2	640.8	-0.36	0.28	0.49	12.93	-24.4	-30.6	-31.6	0.10	0.15	-90.6	-114.3	-134.3	-155.5	3.5	-103.27
1.00	11.01	649.0	646.0	643.6	-0.34	0.31	0.53	12.95	-24.3	-30.9	-31.7	0.13	0.16	-90.9	-114.6	-134.4	-153.8	6.0	-110.68
1.25	11.01	651.8	648.7	646.3	-0.32	0.34	0.56	12.97	-24.3	-31.2	-31.9	0.14	0.17	-92.9	-113.9	-134.5	-154.1	8.5	-111.92
1.50	11.01	654.5	651.5	649.0	-0.30	0.37	0.59	12.99	-24.3	-31.4	-31.5	0.16	0.18	-91.9	-114.1	-134.4	-155.1	10.0	-113.97
1.75	11.26	657.3	654.2	651.6	-0.27	0.39	0.62	13.00	-24.4	-31.6	-30.7	0.17	0.20	-90.7	-113.9	-134.2	-153.8	20.8	-119.98
2.00	11.01	660.2	657.0	654.4	-0.25	0.42	0.64	13.02	-24.4	-32.0	-30.3	0.18	0.21	-91.6	-114.2	-134.1	-155.0	35.5	-125.65
2.25	11.26	663.0	659.8	657.2	-0.23	0.44	0.67	13.04	-24.3	-32.5	-30.2	0.19	0.22	-91.3	-114.4	-134.5	-154.5	60.7	-129.70
2.50	11.78	666.0	662.6	660.0	-0.21	0.46	0.69	13.07	-24.3	-33.0	-29.9	0.19	0.23	-91.0	-114.2	-134.5	-154.3	86.7	-133.21
2.75	11.78	668.9	665.5	662.8	-0.19	0.49	0.71	13.08	-24.2	-33.2	-30.2	0.20	0.24	-90.4	-113.6	-134.2	-154.1	100.0	-134.74
3.00	11.52	671.9	668.5	665.7	-0.18	0.51	0.73	13.10	-24.1	-33.5	-31.0	0.20	0.25	-89.7	-114.1	-134.3	-153.0	148.1	-137.52
3.25	12.03	674.9	671.4	668.6	-0.16	0.52	0.75	13.12	-24.1	-34.0	-31.3	0.19	0.27	-91.8	-113.8	-134.1	-154.2	177.0	-139.20
3.50	12.03	677.9	674.4	671.6	-0.14	0.54	0.76	13.15	-24.0	-34.7	-31.1	0.19	0.28	-90.3	-114.5	-134.1	-152.8	211.6	-140.40
3.75	11.52	681.0	677.4	674.5	-0.13	0.55	0.78	13.17	-24.0	-35.3	-31.1	0.18	0.30	-90.4	-113.4	-133.9	-153.0	302.4	-143.61
4.00	11.78	684.0	680.3	677.4	-0.12	0.56	0.78	13.19	-23.9	-35.8	-30.9	0.17	0.31	-89.6	-113.7	-133.6	-153.1	361.5	-145.44
4.25	12.03	687.0	683.2	680.4	-0.11	0.57	0.79	13.20	-23.7	-36.5	-30.2	0.16	0.32	-89.2	-113.5	-134.2	-153.3	507.5	-148.16
4.50	11.26	689.9	686.2	683.2	-0.10	0.57	0.79	13.22	-23.6	-37.6	-29.7	0.15	0.33	-91.4	-113.8	-134.3	-154.0	600.0	-149.69
4.75	11.26	692.8	689.0	686.1	-0.09	0.57	0.79	13.24	-23.4	-39.0	-30.0	0.14	0.33	-89.4	-114.1	-133.8	-153.2	851.6	-153.40
5.00	11.26	695.7	691.8	688.9	-0.09	0.57	0.78	13.25	-23.4	-40.4	-30.2	0.13	0.33	-90.2	-113.3	-133.7	-153.2	1000.0	-153.69

*at 25°C unless mentioned otherwise

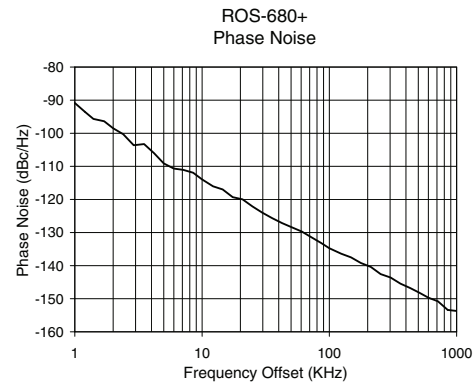
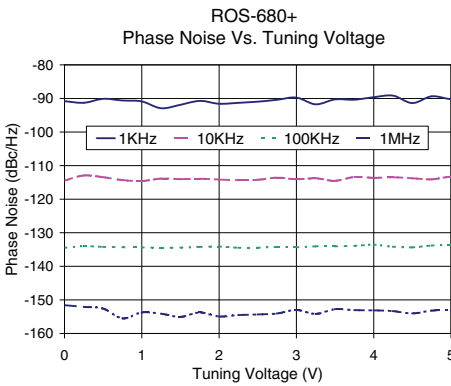
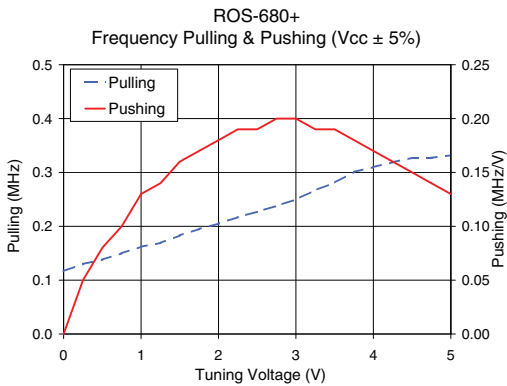
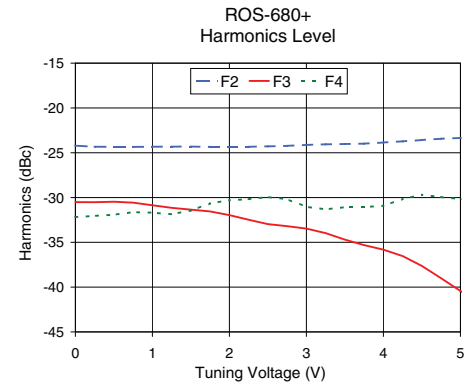
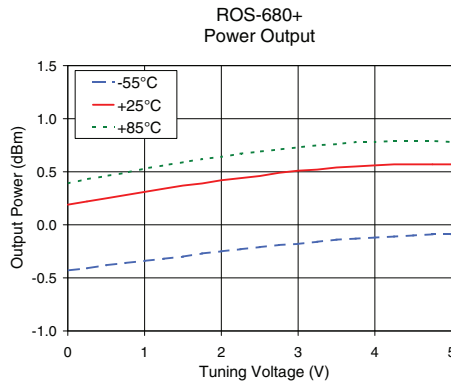
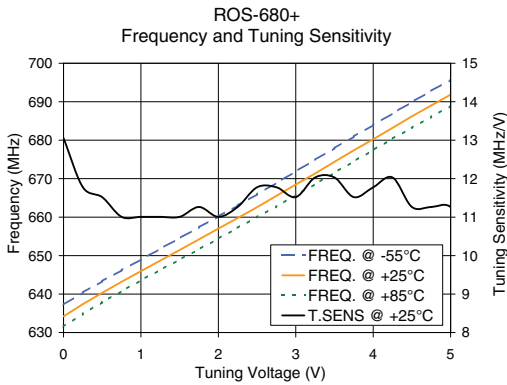

For detailed performance specs & shopping online see web site

P.O. Box 350166, Brooklyn, New York 11235-0003 (718) 934-4500 Fax (718) 332-4661 The Design Engineers Search Engine Provides ACTUAL Data Instantly at minicircuits.com

Notes: 1. Performance and quality attributes and conditions not expressly stated in this specification sheet are intended to be excluded and do not form a part of this specification sheet. 2. Electrical specifications and performance data contained herein are based on Mini-Circuit's applicable established test performance criteria and measurement instructions. 3. The parts covered by this specification sheet are subject to Mini-Circuits standard limited warranty and terms and conditions (collectively, "Standard Terms"); Purchasers of this part are entitled to the rights and benefits contained therein. For a full statement of the Standard Terms and the exclusive rights and remedies thereunder, please visit Mini-Circuits' website at www.minicircuits.com/MCLStore/terms.jsp.