

Ceramic

Low Pass Filter

LFCN-800

50Ω DC⁽¹⁾ to 800 MHz

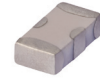

Generic photo used for illustration purposes only

CASE STYLE: FV1206

Maximum Ratings

Operating Temperature	-55°C to 100°C
Storage Temperature	-55°C to 100°C
RF Power Input*	9W max. at 25°C

* Passband rating, derate linearly to 4W at 100°C ambient. Permanent damage may occur if any of these limits are exceeded.

Pin Connections

RF IN	1
RF OUT	3
GROUND	2,4

Outline Drawing

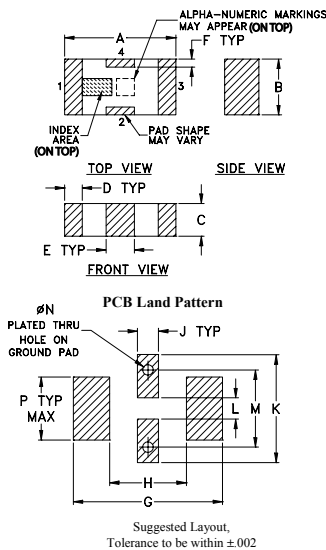

Outline Dimensions (inch/mm)

A	B	C	D	E	F	G
.126	.063	.037	.020	.032	.009	.169
3.20	1.60	0.94	0.51	0.81	0.23	4.29

H	J	K	L	M	N	P	wt
.087	.024	.122	.024	.087	.012	.071	grams
2.21	0.61	3.10	0.61	2.21	0.30	1.80	.020

Demo Board MCL P/N: TB-270 Suggested PCB Layout (PL-137)

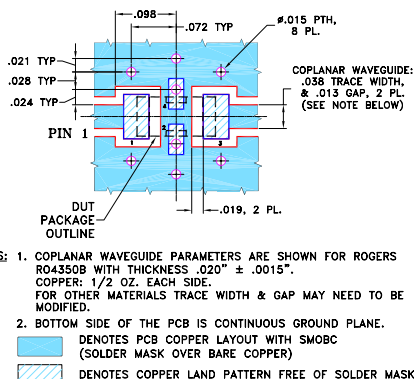

Features

- excellent power handling, 9W
- small size
- 5 sections
- temperature stable
- LTCC construction

Applications

- harmonic rejection
- VHF/UHF transmitters/receivers
- lab use

Electrical Specifications^(1,2) at 25°C

Parameter	F#	Frequency (MHz)	Min.	Typ.	Max.	Unit	
Pass Band	Insertion Loss	DC-F1	DC-800	—	—	1.3	dB
	Freq. Cut-Off	F2	990	—	3.0	—	dB
	VSWR	DC-F1	DC-800	—	1.2	—	:1
Stop Band	Rejection Loss	F3	1400	20	—	—	dB
		F4-F5	1500-2000	—	30	—	dB
		F6	4500	—	20	—	dB
	VSWR	F3-F6	1400-4500	—	20	—	:1

(1) In Applications where DC isolation to ground is required, coupling capacitors are recommended to avoid DC leakage. Alternatively, if DC pass IN-OUT is required, Mini-Circuits' "D" suffix version of this model will support DC IN-OUT, and provide >100 MOhm isolation to ground.
(2) Measured on Mini-Circuits Characterization Test Board TB-270.

Typical Frequency Response

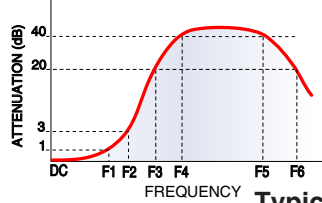

Electrical Schematic

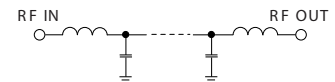

Typical Performance Data at 25°C

Frequency (MHz)	Insertion Loss (dB)	VSWR (:1)
10.00	0.06	1.01
100.00	0.14	1.07
800.00	0.85	1.41
990.00	3.87	4.47
1030.00	5.38	6.39
1330.00	20.50	39.49
1400.00	24.29	48.26
1500.00	30.05	52.65
1635.00	40.35	59.91
1785.00	52.35	66.82
2000.00	39.14	72.39
3000.00	31.57	86.86
3500.00	30.42	69.49
4500.00	27.52	62.05
5000.00	25.04	42.38

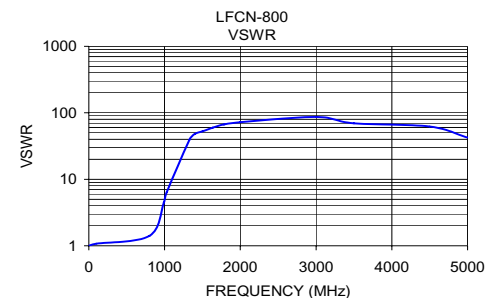
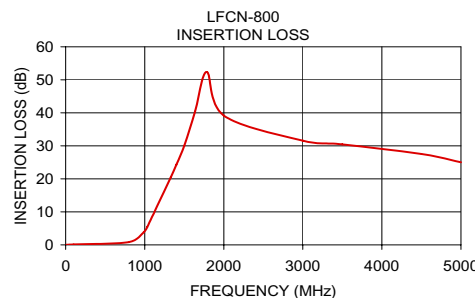

Notes

- Performance and quality attributes and conditions not expressly stated in this specification document are intended to be excluded and do not form a part of this specification document.
- Electrical specifications and performance data contained in this specification document are based on Mini-Circuit's applicable established test performance criteria and measurement instructions.
- The parts covered by this specification document are subject to Mini-Circuits standard limited warranty and terms and conditions (collectively, "Standard Terms"); Purchasers of this part are entitled to the rights and benefits contained therein. For a full statement of the Standard Terms and the exclusive rights and remedies thereunder, please visit Mini-Circuits' website at www.minicircuits.com/MCLStore/terms.jsp

