

NON-CATALOG

Surface Mount

Voltage Controlled Oscillator

JTOS-850VW

Wide Band 400 to 850 MHz

Features

- excellent tuning linearity
- octave bandwidth
- low phase noise, -136 dBc/Hz at 1 MHz offset, typ.
- aqueous washable

Applications

- cellular
- UHF
- wideband frequency synthesizers



CASE STYLE: BK377
PRICE: Contact Sales Dept.

Electrical Specifications

FREQUENCY (MHz)		POWER OUTPUT (dBm)	TUNING VOLTAGE (V)		PHASE NOISE (dBc/Hz) SSB at offset frequencies: Typ.				PULLING pk-pk @ 12 dB (MHz)	PUSHING (MHz/V)	TUNING SENSITIVITY (MHz/V)	HARMONICS (dBc)	3 dB MODULATION BANDWIDTH (MHz)	DC OPERATING POWER	
Min.	Max.	Typ.	Min.	Max.	1 kHz	10 kHz	100 kHz	1 MHz	Typ.	Typ.	Typ.	Typ.	Typ.	Vcc (volts)	Current (mA) Max.
400	850	+6.0	0.5	18	-74	-96	-116	-136	6.0	1.5	15-80	-20	0.185	5	20

Pin Connections

RF OUT	13
VCC	2
V-TUNE	5
GROUND	1,3,4,6,7,8,9,10,11,12,14

Maximum Ratings

Operating Temperature	-55°C to 85°C
Storage Temperature	-55°C to 100°C
Absolute Max. Supply Voltage (Vcc)	+6V
Absolute Max. Tuning Voltage (Vtune)	+20V

all specifications: 50 ohm system
Permanent damage may occur if any of these limits are exceeded.

Outline Drawing

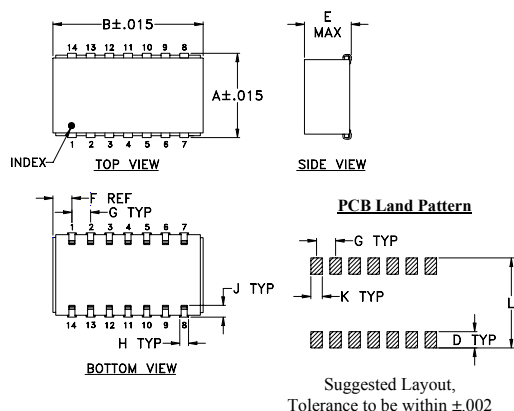

Demo Board MCL PIN: TB-04
Suggested PCB Layout (PL-005)

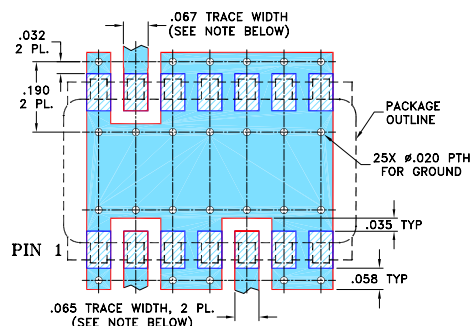

Outline Dimensions (inch/mm)

A	B	C	D	E	F	G	H	J	K	L	wt
.505	.800	--	.100	.250	.100	.100	.047	.065	.065	.525	grams
12.83	20.32	--	2.54	6.35	2.54	2.54	1.19	1.65	1.65	13.34	3.0



P.O. Box 350166, Brooklyn, New York 11235-0003 (718) 934-4500 Fax (718) 332-4661 The Design Engineers Search Engine Provides ACTUAL Data Instantly at minicircuits.com

Notes: 1. Performance and quality attributes and conditions not expressly stated in this specification sheet are intended to be excluded and do not form a part of this specification sheet. 2. Electrical specifications and performance data contained herein are based on Mini-Circuit's applicable established test performance criteria and measurement instructions. 3. The parts covered by this specification sheet are subject to Mini-Circuits standard limited warranty and terms and conditions (collectively, "Standard Terms"); Purchasers of this part are entitled to the rights and benefits contained therein. For a full statement of the Standard Terms and the exclusive rights and remedies thereunder, please visit Mini-Circuits' website at www.minicircuits.com/MCLStore/terms.jsp.

For detailed performance specs & shipping online see web site

REV. D
M102713
JTOS-850VW
ED-8643/1
SK/TD/CP
120621
Page 1 of 2

NON-CATALOG

Performance Data & Curves

JTOS-850VW

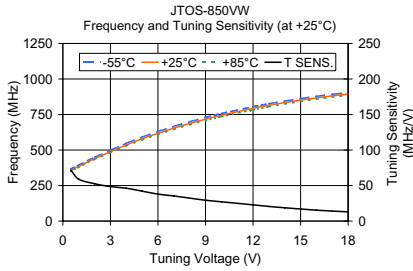

V TUNE	TUNING SENS. (MHz/V)	FREQUENCY (MHz)			POWER OUTPUT (dBm)		
		-55°C	+25°C	+85°C	-55°C	+25°C	+85°C
0.50	71.96	366.38	355.68	349.01	6.00	6.52	5.37
1.00	58.97	393.77	385.16	380.30	5.24	6.07	5.34
2.00	52.59	448.83	439.44	433.98	4.64	5.38	4.99
3.00	48.53	498.80	488.55	482.39	5.81	6.43	6.05
4.00	46.26	547.11	535.62	528.32	6.49	7.09	6.84
5.00	42.18	591.08	578.72	570.49	6.24	7.01	6.98
6.00	37.97	630.57	617.97	609.06	7.12	7.56	7.20
7.00	35.42	666.84	654.03	644.73	8.04	8.54	8.08
8.00	32.27	699.80	687.10	677.50	8.69	9.13	8.56
9.00	29.33	729.67	717.14	707.32	8.50	9.37	8.97
10.00	27.12	757.01	744.77	734.76	7.94	8.87	8.64
12.00	22.79	805.03	793.55	783.42	7.33	8.27	7.93
13.00	20.60	826.02	814.71	804.69	7.01	8.02	7.77
14.00	18.71	845.12	833.90	823.95	6.79	7.78	7.56
15.00	16.94	862.40	851.26	841.51	6.66	7.60	7.39
16.00	15.37	878.01	866.99	857.49	6.44	7.48	7.30
17.00	14.11	892.15	881.42	872.10	6.05	7.23	7.21
18.00	12.92	905.11	894.66	885.40	5.51	6.82	6.96

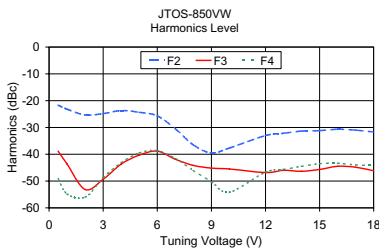
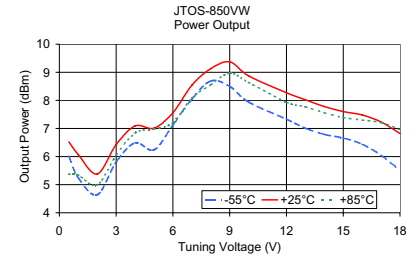

V TUNE	HARMONICS (dBc)			FREQ. PUSHING (MHz/V)
	F2	F3	F4	
0.50	-21.66	-38.83	-49.16	1.35
1.00	-23.17	-43.67	-54.84	2.51
2.00	-25.33	-53.17	-56.00	1.17
3.00	-24.84	-49.34	-48.84	0.91
4.00	-23.67	-43.67	-43.17	0.38
5.00	-24.33	-40.33	-39.50	0.25
6.00	-25.67	-38.84	-38.67	0.27
7.00	-30.50	-41.84	-41.50	0.53
8.00	-36.50	-44.17	-46.00	0.84
9.00	-39.50	-45.17	-50.34	1.06
10.00	-37.67	-45.50	-54.17	1.40
12.00	-33.00	-46.83	-46.67	2.06
13.00	-32.17	-46.00	-45.67	2.36
14.00	-31.34	-46.34	-44.50	2.64
15.00	-31.16	-45.66	-43.50	2.91
16.00	-30.67	-44.50	-43.33	2.99
17.00	-31.00	-44.84	-44.00	2.98
18.00	-31.67	-46.17	-44.17	2.92

